

Visit nipponpulse.com to download 3D CAD drawings and 2D prints of this motor.

Electrical Specs	L250SSS	L250SS	L250DS	L250TS	L250QS
Continuous Force ¹	7.1N (1.6lbs)	17N (3.8lbs)	29N (6.52lbs)	44N (9.89lbs)	55N (12.36lbs)
Continuous Current ¹	1.9Arms	1.3Arms	1.1Arms	1.0Arms	
Acceleration Force ²	28N (6.29lbs)	69N (15.5lbs)	118N (26.53lbs)	176N (39.57lbs)	220N (49.46lbs)
Acceleration Current ²	7.6Arms	5.1Arms	4.3Arms	4.2Arms	3.9Arms
Force Constant (K_f)	3.7N/amp	13N/amp	28N/amp	42N/amp	57N/amp
Back EMF (K_e)	1.2V/m/s	4.5V/m/s	9.2V/m/s	14V/m/s	19V/m/s
Resistance 25°C ³	2.9Ω	6.5Ω	13Ω	19Ω	25Ω
Inductance ³	2.8mH	11mH	19mH	28mH	37mH
Electric Time Constant	0.96ms	1.75ms	1.47ms	1.48ms	1.45ms
Fundamental Motor Constant (K_m)	2.194N√W	5.28N√W	7.78N√W	9.66N√W	11.23N√W
Magnetic Pitch (North-North)	30mm (1.18in)	60mm (2.36in)			

Is this the proper Linear Shaft Motor for your application? Use our [SMART sizing program](#) to assist in your decision.

This motor can be customized to fit your application demands; contact your application engineer for more information.

¹ Based on a temp rise of coil surface of 110°K over 25°C ambient temperature stalled forcer, and no external cooling or heat sinking.

² Can be maintained for a maximum of 40 seconds. Higher forces and current possible for short periods of time, contact Nippon Pulse for more information.

³ All winding parameters listed are measured line-to-line (phase-to-phase).

Thermal Specs	L250SSS	L250SS	L250DS	L250TS	L250QS
Max Phase Temperature ⁴	135°C (275°F)				
Thermal Resistance (Coil) (K_c)	11.0°C/W (51.8°F/W)	10.0°C/W (50°F/W)	7.7°C/W (45.86°F/W)	5.3°C/W (41.54°F/W)	4.6°C/W (40.28°F/W)

⁴The standard temperature difference between the coil and the forcer surface is 40°C.

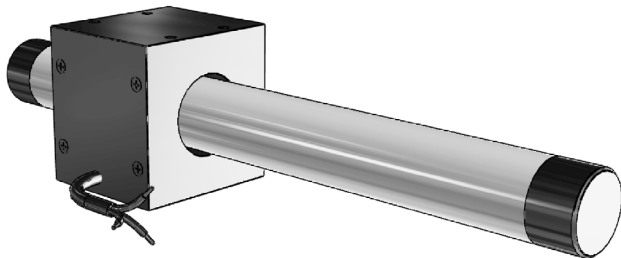

Bus Voltage

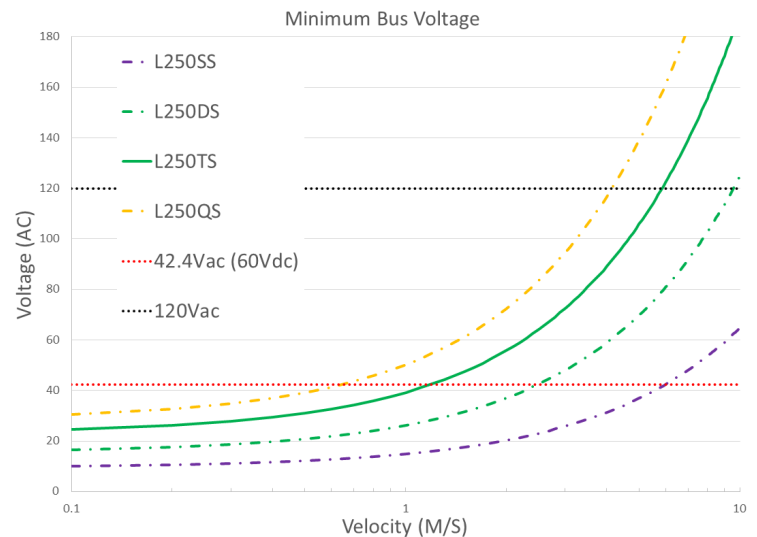

These motors have not received a CE Declaration of Conformity, and as such are designated FGA.

Forcer Specs	L250SSS	L250SS	L250DS	L250TS	L250QS
Forcer Length (A)	30mm (1.18in)	50mm (1.97in)	80mm (3.15in)	110mm (4.33in)	140mm (5.51in)
Forcer Width	56mm (2.2in)				
Forcer Screw Pitch (P)	20mm (0.79in)	40mm (1.57in)	70mm (2.8in)	100mm (3.94in)	130mm (5.12in)
Forcer Weight	0.24kg (0.53lbs)	0.43kg (0.95lbs)	0.72kg (1.59lbs)	1.0kg (2.20lbs)	1.4kg (3.09lbs)
Gap	2.0mm (0.08in)				
Screw	M4				
Tightening Torque	1.5 Nm				

Tolerances are as follows:

Dimension (mm)	Tolerance (mm)
0 - 6	±0.1
7 - 30	±0.2
31 - 120	±0.3
121 - 315	±0.5
316 - 1000	±0.8
1001 - 2000	±1.2
2000 -	±1.5

L = See Shaft Length
L1 = Usable Stroke + A
L2 = See Support Length
A = See Forcer Length
P = See Forcer Screw Pitch

Unless otherwise specified,
dimensions are in mm

Note: Cable length 300mm. The bending radius of the motor cable should be 36.6mm (wire diameter 6.1 * 6) as suggested by the wire manufacturer. This radius should be maintained. Use supplied connector to attach the proper high-flex cable as required by your application.

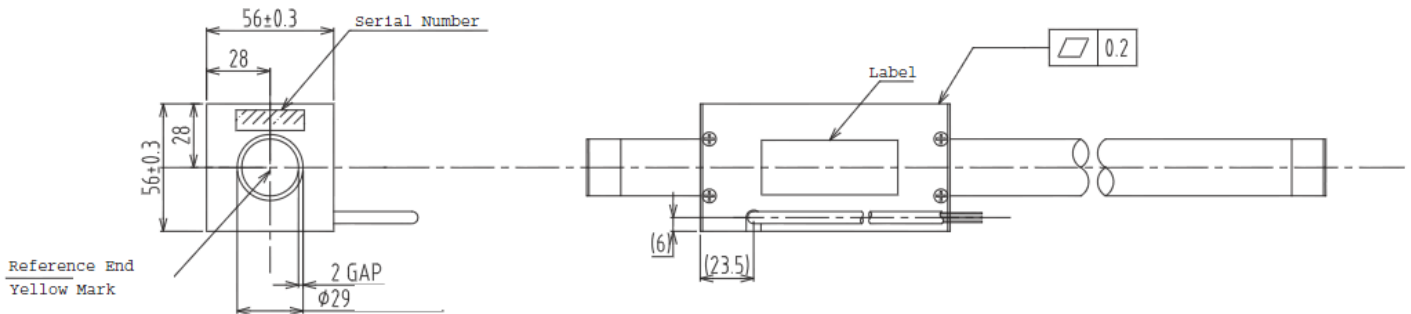
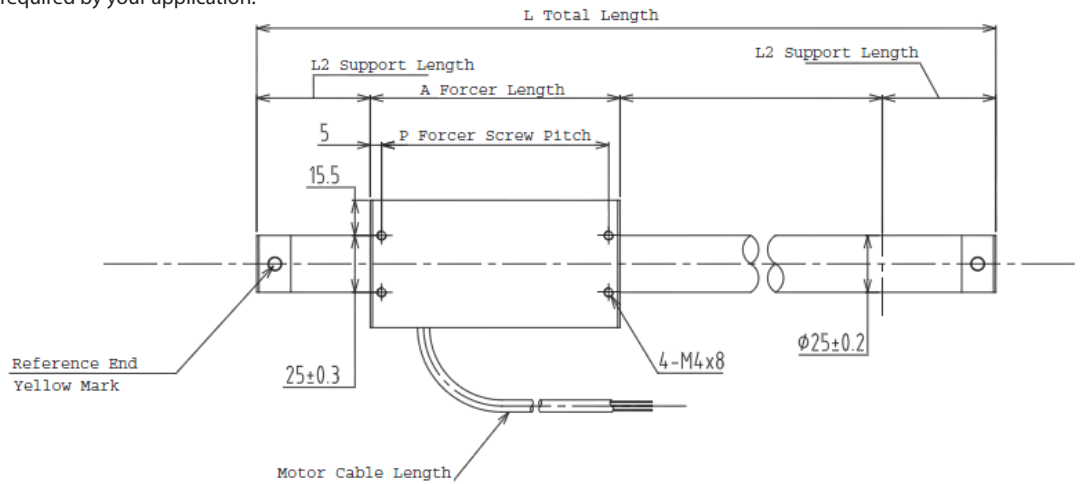

L250SSS:

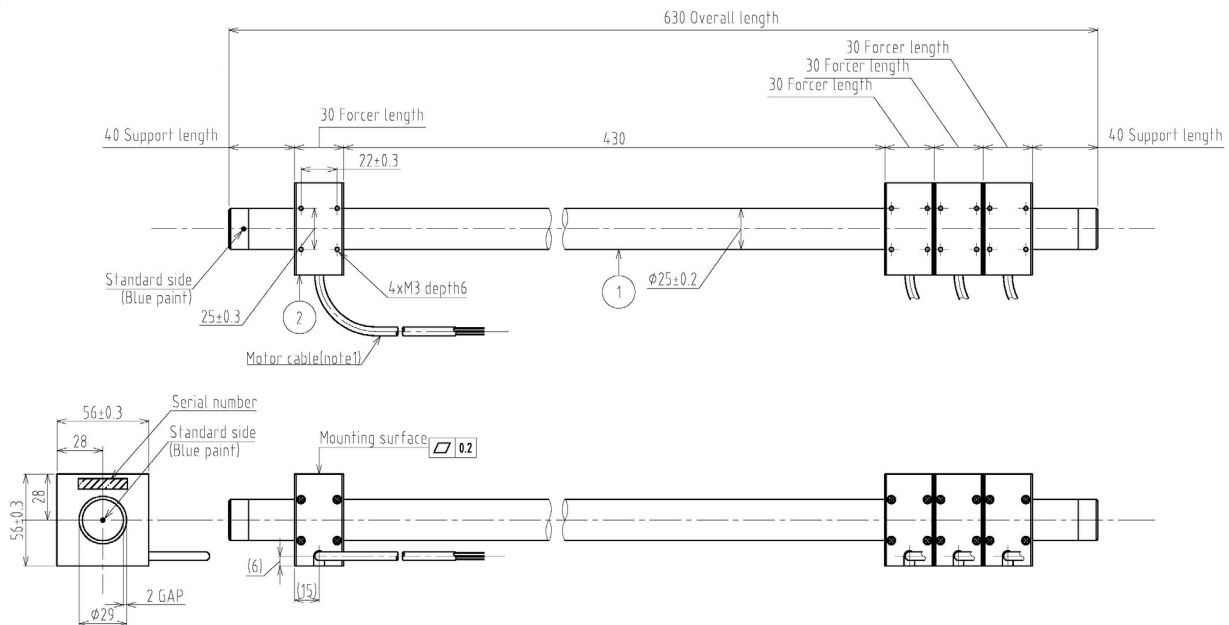

Note: Metric units guaranteed. Imperial (United States customary) units are calculated.

Linear Shaft Motor Part Numbering Guide (SS Series)

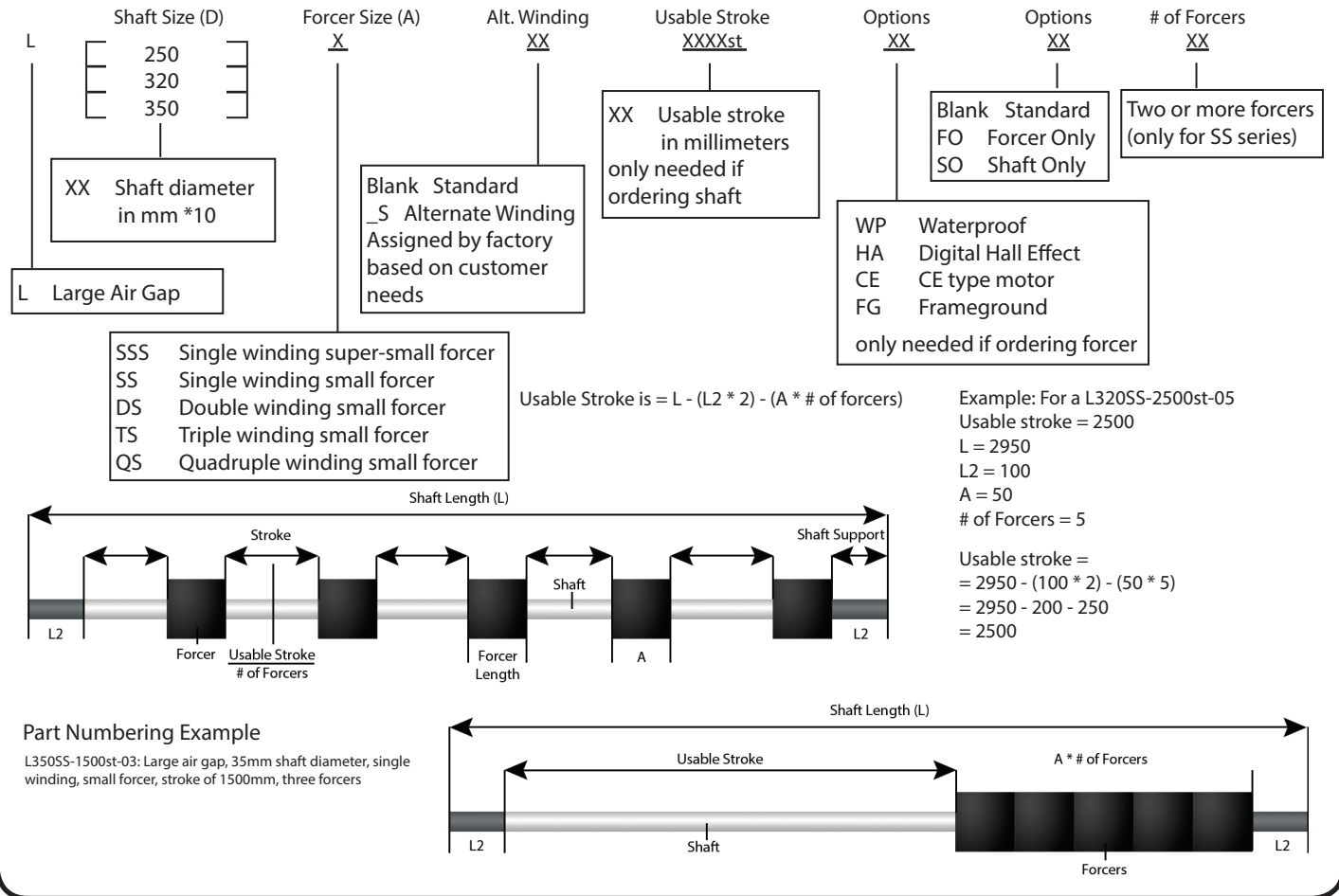

THM Option

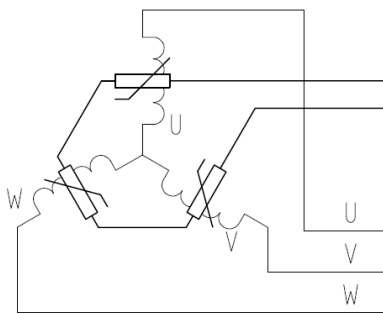

4. Thermistor
 PTCSL20T071DBE (Vishay)

Thermocouple

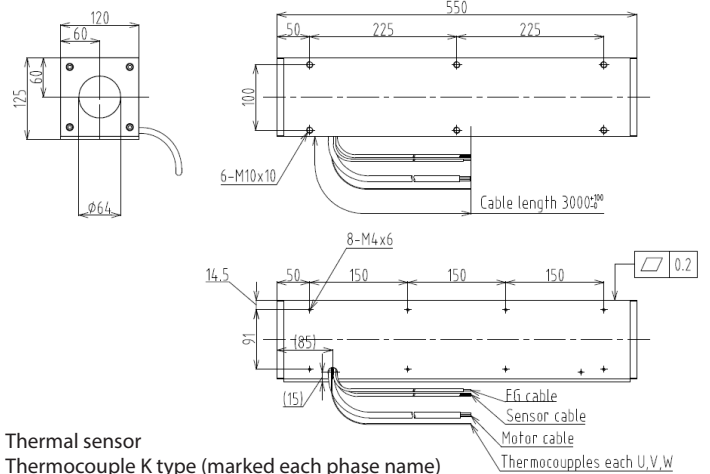

Support and Bending

Stroke	Support Length (L2)	Max. Bending
0~850	50mm	0.00mm
900~1650	70mm	0.30mm
1700~max	100mm	0.70mm

For assistance in selecting the best motor for your application, contact Nippon Pulse to speak with an applications engineer. 1-540-633-1677