

Constant Voltage Driver for Unipolar Stepper Motors



Nippon Pulse's AD1111 is a constant voltage driver board designed for 2-phase unipolar stepper motors.

With its standard features, including full and half stepping excitation modes and switch-selectable input signal, this stepper driver represents the most economical solution for simple unipolar constant drive conditions.

Features:

- Two excitation modes (Full, half)
- Output current of 0.35 A
- Motor/Off signal
- RoHS compliance
- Switch-selectable two-pulse or one-pulse CW/CCW command signaling

Applications:

- Experimentation/Evaluation
- CCTV, Security
- Office Automation
- ATM, Cash recycler, POS
- Lab Automation
- Medical
- Printer and Scanner
- Pumps and Valve

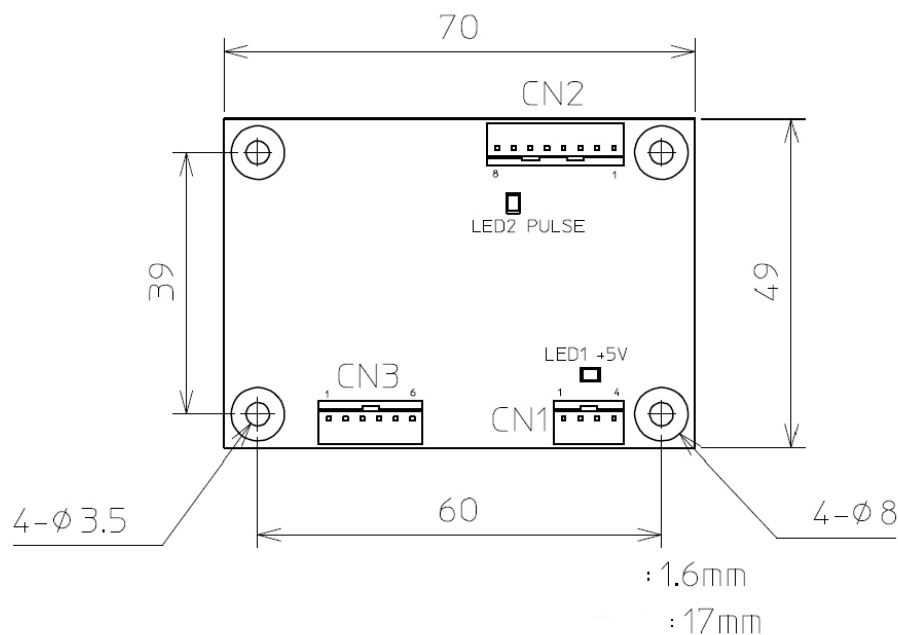

General Specifications:

AD1111 Driver Board		
<i>Electrical Specs</i>	Control Method	Unipolar Constant Voltage
	Input Voltage	DC 5V \pm 5%
	Excitation Method	2 phase (FULL), 1-2 phase (HALF)
	Output Voltage/ Current	DC 5V to 30 V 0.35 A per phase
	Input Interface	TTL Input Low: 0 -0.5 V High: 1.9V – VCC All input pulse signals must last 10 microseconds or more. After commanding a change in direction, or Full/Half step mode, 10 microseconds must elapse before sending step signals.
	CW/CCW Command Pulse	One of the following methods can be selected by SW1: 1. Two pulse method (CW/CCW) 2. One pulse method (CLK/DIR)
	MOT/OFF Signals	Set with SW3: Logic High = Motor Energized Logic Low = Motor Off
<i>Environmental Conditions</i>	Operating Temp.	0 to 50°C
	Operating Humidity	0 to 80%RH (No condensation)
	Storage Temp.	-10 to 60°C
<i>Other</i>	Weight	20 g
	Cooling System	Natural cooling
	Dimensions	70 (W) x 49 (D) x 17 (H)
	Protection Circuit	315 mA fuse for motor power