

### PF(C)25 w/P Gearhead

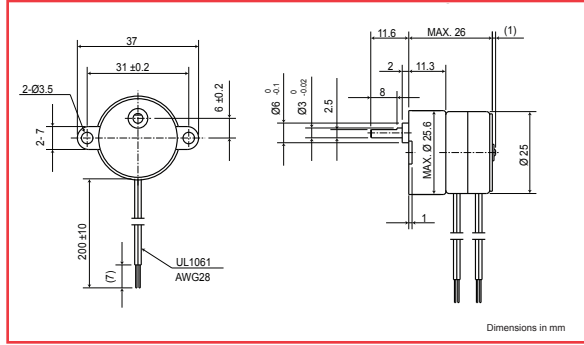

Gear Ratio	6/25	1/5	3/25	1/10	2/25	1/15	3/50	1/20
Maximum Torque	20mN-m				50mN-m			

Gear Ratio	1/25	1/30	1/50	1/60	1/75
Maximum Torque	20mN-m				

Gear Ratio	1/100	1/120	1/125	1/150	1/200	1/250	1/300	1/20
Maximum Torque	100mN-m							

### PF(C)42/42H/42T w/H Gearhead

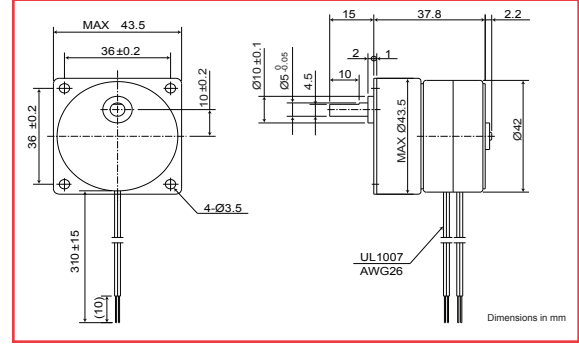

Gear Ratio	6/25	1/5	3/25	1/10	2/25	1/15	1/20	1/25
Maximum Torque	200mN-m				250mN-m			

Gear Ratio	1/30	1/50	1/60	2/125	1/75
Maximum Torque	300mN-m				

Gear Ratio	1/100	1/120	1/125	1/150	1/200	1/300		L
Maximum Torque	400mN-m						PF42/PFC42H	37.8
							PF42T/PFC42T	31

### PF35/35T w/M Gearhead

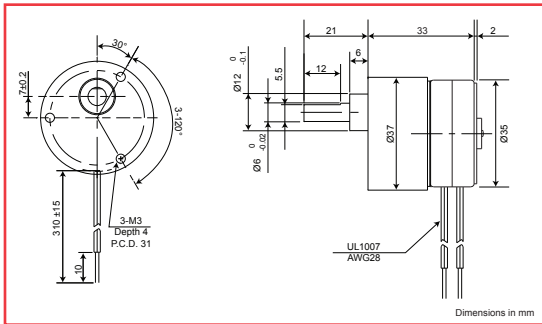

	L
PF35	19.1
PF35T	13.5

Gear Ratio	1/5	1/6	1/10	1/18	1/30
Maximum Torque	100mN-m			200mN-m	

Gear Ratio	1/40	1/50	1/60	1/75	1/90	1/100	1/120
Maximum Torque	300mN-m						

Gear Ratio	1/125	1/150	1/180	1/200	1/270	1/300
Maximum Torque	600mN-m					

### PF(C)55/55H w/F Gearhead

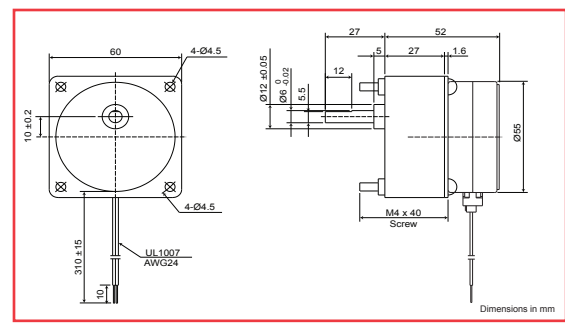

Gear Ratio	6/25	1/5	3/25	1/10	2/25	1/15	3/50	1/20
Maximum Torque	400mN-m							

Gear Ratio	1/25	1/30	1/50	1/60
Maximum Torque	700mN-m			

Gear Ratio	2/125	1/75	3/250	1/100	1/125	1/150	1/250	1/300
Maximum Torque	1000mN-m							

### PF35/35T w/H Gearhead

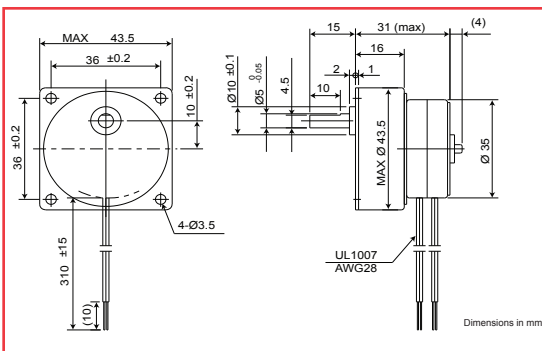

	L
PF35	36.6
PF35T	31

Gear Ratio	6/25	1/5	3/25	1/10	2/25	1/15	3/50	1/20	1/25
Maximum Torque	200mN-m				250mN-m				

Gear Ratio	1/30	1/50	1/60	2/125	1/75
Maximum Torque	300mN-m				

Gear Ratio	1/100	1/120	1/125	1/150	1/200	1/300
Maximum Torque	400mN-m					

### PF(C)55/55H w/F(BB) Gearhead

F(BB) gearhead provides ball-bearing support for all stages, ensuring long service life.

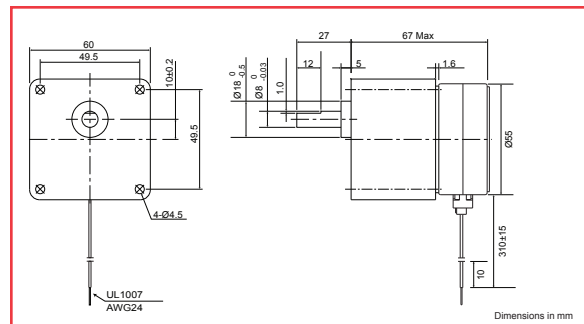

Gear Ratio	1/3	1/5	2/15	1/10	2/25	1/15	1/20
Maximum Torque	400mN-m		500mN-m		600mN-m		800mN-m

Gear Ratio	1/25	1/30	1/50	1/60
Maximum Torque	900mN-m	1100mN-m	1600mN-m	

Gear Ratio	1/75	1/100	1/125	1/150	1/180		
Maximum Torque	2500mN-m					Reduction Ratio	L
						1/3 to 1/15	32
						1/20 to 1/180	42