

Specifications

Specification	Unit	PFC42H-48			
		Unipolar		Bipolar	
Type of Winding		Unipolar		Bipolar	
Excitation Mode*		Full step (2-2)			
Step Angle	°	7.5 ±5%			
Steps Per Revolution*		48			
Rated Voltage	V	12	5	12	5
Resistance	Ω	70	12	70	12
Inductance	mH	39	6.6	80	13
Holding Torque	mN·m	50	50	70	70
Rotor Inertia	kg·m ²	27 x 10 ⁻⁷			
Starting Pulse Rate*	pps	290			
Slewing Pulse Rate*	pps	320			
Operating Temp. Range	°C	-30 to +80			
Temperature Rise*	°C	55			
Weight	g	160			

Torque Curve (pull-out torque)*

Bipolar Constant Voltage (48P1)

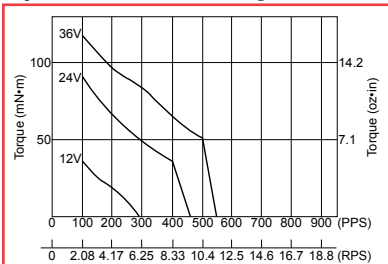

Coil Resistance: 70Ω

Bipolar Constant Current (48Q1)

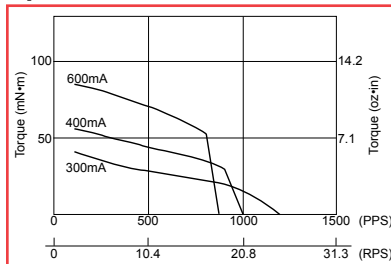

Coil Resistance: 12Ω Supply Voltage: 24V

Unipolar Constant Voltage (48C1)

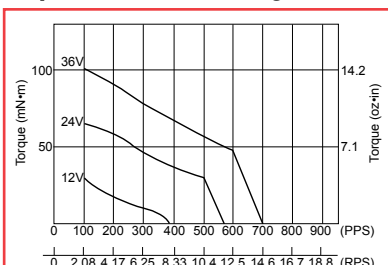

Coil Resistance: 70Ω

Unipolar Constant Current (48D1)

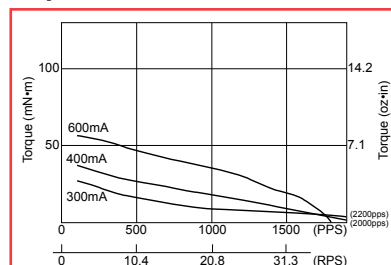

Coil Resistance: 12Ω Supply Voltage: 24V

Dimensions of Geared Model

PFC42H w/H Gear Head

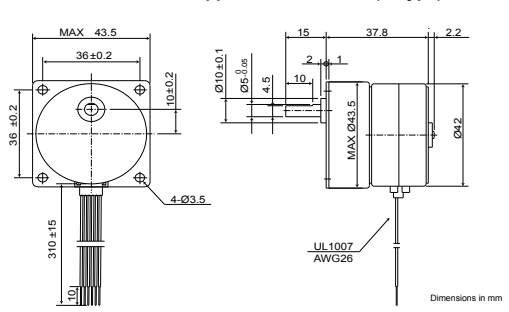

Gear Ratio	6/25	1/5	3/25	1/10	2/25	1/15	1/20	1/25
Maximum Torque	200mN·m				250mN·m			
Gear Ratio	1/30	1/50	1/60	2/125	1/75			
Maximum Torque	300mN·m							
Gear Ratio	1/100	1/120	1/125	1/150	1/200	1/300		
Maximum Torque	400mN·m							

* - All tin-can motor specifications are based on full-step constant voltage operation
Magnet type: Anisotropic

Note: Torque curves are for reference only and are not guaranteed.