

Motionnet

G9001/G9002

(Center device / I/O device)

User's Manual

[Preface]

Thank you for considering our super high-speed serial communicator LSI, the "G9000."
To learn how to use the G9000, read this manual to become familiar with the product.
The handling precautions for installing this LSI are described at the end of this manual. Make sure to read them before installing the LSI.

[What Motionnet is]

As a next generation communication system, the Motionnet can construct faster and more volume large, scale-systems with wire saving than conventional T-NET system (conventional LSI product to construct serial communication system by NPM). Further, it has data communication function which the T-NET does not have, so that it can control data control devices such as PCL series (pulse train generation LSI made by NPM).

The Motionnet system consists of one center device connected to a CPU bus, a maximum of 64 local devices, all connected using cables of two or three conductive cores

[Cautions]

- (1) Copying all or any part of this manual without written approval is prohibited.
- (2) The specifications of this LSI may be changed to improve performance or quality without prior notice.
- (3) Although this manual was produced with the utmost care, if you find any points that are unclear, wrong, or have inadequate descriptions, please let us know.
- (4) We are not responsible for any results that occur from using this LSI, regardless of item (3) above.

INDEX

I. Center device (G9001).....	I-1
1. Outline.....	I-3
2. Features.....	I-3
3. General specifications.....	I-4
3-1. Communication system specifications.....	I-4
3-2. Center device specifications (G9001).....	I-5
4. Hardware description.....	I-6
4-1. A list of terminals (QFP-64).....	I-6
4-2. Terminal allocation diagram.....	I-8
4-3. Entire block diagram.....	I-9
4-4. Functions of terminals.....	I-10
4-4-1. CLK.....	I-10
4-4-2. RST.....	I-10
4-4-3. CKSL.....	I-10
4-4-4. IF0, IF1.....	I-11
4-4-5. CS.....	I-11
4-4-6. RD, WR, A0 and WRQ.....	I-11
4-4-7. INT.....	I-11
4-4-8. IFB.....	I-11
4-4-9. A1 to A8.....	I-11
4-4-10. D0 to D7.....	I-11
4-4-11. D8 to D15.....	I-12
4-4-12. SPD0, SPD1.....	I-12
4-4-13. SO.....	I-12
4-4-14. SOEH, SOEL.....	I-12
4-4-15. SIA, SIB.....	I-12
4-4-16. MCRY.....	I-13
4-4-17. MERR.....	I-13
4-4-18. MERF.....	I-13
4-4-19. MSYN.....	I-13
4-5. Address map.....	I-14
4-5-1. "Device information" area.....	I-18
4-5-2. "I/O communication area flags".....	I-19
4-5-3. "Change to Input Port Interrupt Setting" area.....	I-20
4-5-4. "Change-In-Input Interrupt Flag" area.....	I-21
4-5-5. "Port data" area.....	I-21
4-6. Status.....	I-22
4-7. Interrupt status.....	I-23
4-8. Command.....	I-24
5. Description of the software.....	I-27
5-1. Outline of control.....	I-27
5-1-1. Communication control.....	I-27
5-1-2. Communication type.....	I-27
5-1-3. Input change interrupt.....	I-29
5-1-4. Break function.....	I-29
5-1-5. Control of communication errors.....	I-29
5-2. Operating procedure.....	I-31
5-2-1. Reset.....	I-31
5-2-2. I/O communication procedures.....	I-31
5-2-3. Data communication procedure.....	I-31
5-2-4. Exclude a device with an error.....	I-31
5-2-5. Restoring excluded devices to cyclic communications.....	I-31
5-3. Status after reset.....	I-31

- 6. How to calculate the communication cycle time I-32
 - 6-1. Time required for one cycle I-32
 - 6-2. Time required for one complete data communication I-32
 - 6-3. Total cycle time (including data communication) I-32
- 7. Electrical Characteristics I-33
 - 7-1. Absolute maximum ratings I-33
 - 7-2. Recommended operating conditions I-33
 - 7-3. DC characteristics I-33
 - 7-4. AC characteristics I-34
 - 7-4-1. System clock I-34
 - 7-4-2. Reset timing I-34
 - 7-4-3. I/F mode4 (IF1=H, IF0=H) I-35
 - 7-4-4. I/F mode 3 (IF1=H, IF0=L) I-36
 - 7-4-5. I/F mode 2 (IF1=L, IF0=H) I-37
 - 7-4-6. I/F mode 1 (IF1=L, IF0=L) I-38
- 8. External dimensions I-39

- II. I/O device (G9002)..... II-1
 - 1. Outline II-3
 - 2. Features..... II-3
 - 3. Basic specifications II-3
 - 3-1. I/O device specifications (G9002)..... II-3
 - 4. Hardware Description II-4
 - 4-1. List of terminals (QFP-80) II-4
 - 4-2. Terminal assignment drawings II-6
 - 4-3. Complete block diagram II-7
 - 4-4. Functions of terminals II-8
 - 4-4-1. CLK II-8
 - 4-4-2. RST II-8
 - 4-4-3. CKSL II-8
 - 4-4-4. DN0 to DN5 II-8
 - 4-4-5. DNSM II-9
 - 4-4-6. DNSO II-9
 - 4-4-7. SPD0, SPD1 II-9
 - 4-4-8. TUD II-9
 - 4-4-9. TMD II-9
 - 4-4-10. TOUT II-10
 - 4-4-11. SO II-10
 - 4-4-12. SOEH, SOEL II-10
 - 4-4-13. SOEI II-10
 - 4-4-14. SI II-10
 - 4-4-15. MRER II-10
 - 4-4-16. MSEL II-10
 - 4-4-17. BRK II-10
 - 4-4-18. PMD0 to PMD2 II-11
 - 4-4-19. P0N, P1N, P2N, P3N II-11
 - 4-4-20. P00 to 07, P10 to 17, P20 to 27, P30 to 37 II-11
 - 4-5. Status after reset II-11
 - 5. Electrical Characteristics II-12
 - 5-1. Absolute maximum ratings II-12
 - 5-2. Recommended operating conditions II-12
 - 5-3. DC characteristics II-12
 - 5-4. AC characteristics II-13
 - 5-4-1. System clock II-13
 - 5-4-2. Reset timing II-13
 - 5-4-3. Fixed output data timing II-14
 - 5-4-4. Input data set timing II-14

6. External dimensions	II-15
III. Connection Examples and Recommended Environments	III-1
1. Connection examples	III-3
1-1. An example of a circuit to interface a CPU to a central device	III-3
1-1-1. I/O mode 4 (IF1 = H, IF0 = H)	III-3
1-1-2. I/O mode 3 (IF1 = H, IF0 = L)	III-4
1-1-3. I/O mode 3 (IF1 = L, IF0 = H)	III-5
1-1-4. I/O mode 1 (IF1 = L, IF0 = L)	III-6
1-1-5. Connecting to a CPU without a wait function	III-7
1-2. Access timing	III-8
1-2-1. Normal access	III-8
1-2-1-1. Write to the I/O buffer or the data transfer FIFO	III-8
1-2-1-2. Writing to a memory address	III-9
1-2-1-3. Read timing	III-9
1-2-2. Access by commands	III-10
1-2-2-1. Write operation command	III-10
1-2-2-2. Write data to memory using write commands	III-11
1-2-2-3. Read data from memory using read commands	III-12
1-3. Line transceiver and pulse transformer for the central device	III-13
1-4. Line transceivers and pulse transformers for local devices	III-14
1-5. A connection example of a level shifter	III-15
1-6. Complete configuration	III-16
2. Recommended environment	III-17
2-1. Cable	III-17
2-2. Terminating resistor	III-17
2-3. Pulse transformer	III-17
2-4. I/F chip	III-17
2-5. Parts used in our experiments	III-18
2-6. Other precautions	III-18
IV. Software Examples (flow chart)	IV-1
1. Assumption	IV-3
1-1. Environment and precautions used for the descriptions	IV-3
1-2. Commands used	IV-3
2. Software Examples	IV-4
2-1. Start of the simplest cyclic communication	IV-4
2-2. The central device specifies the data for the local devices that are connected	IV-5
2-3. Set up an input-change interrupt	IV-7
2-4. Check and clear any existing input-change interrupts	IV-9
2-5. Check and clear I/O communication errors	IV-11
2-6. Communication with port data (port data and data device status)	IV-13
2-7. Data communication 1: Put the value in the register of the PCL device (G9003)	IV-15
2-8. Data communication 2: Read a register in a PCL device (G9003)	IV-16
2-9. Data communication 3: Start the PCL device (G9003)	IV-17
2-10. Data communication 4: Start a PCL6045A/B using a CPU emulation device	IV-19
2-11. An example of measuring when a break occurs	IV-23
V. Troubleshooting	V-1
1. Checking the central device	V-1
2. Checking the local devices	V-1
3. Checking the system	V-1

- VI. Handling Precautions VI-1
- 1. Design precautions..... VI-1
- 2. Precautions for transporting and storing LSIs..... VI-1
- 3. Precautions for mounting..... VI-2
 - 3-1. About the central device (G9001)..... VI-2
 - 3-2. I/I device (G9002) VI-3
- 4. Other precautions..... VI-4

I. Center device (G9001)

User's Manual

1. Outline

This LSI is a center device of the Motionnet system.

It contains 256-byte RAM for controlling I/O and 512-byte RAM for data communication, and can control up to 64 local devices.

The local devices can be classified into I/O devices that control input/output signals such as G8014C on the T-NET system, and data device that control by data such as G8015. It allocates device numbers from 0 to 63 for each local device.

One I/O device has 4 ports (1 port = 8 bits) for input/output (select input/output by terminals).

Therefore, connecting all the local devices to the center device as I/O device, you can connect I/Os of 2048 points (64 units x 4 ports x 8 bits = 2048) by serial communication.

One data device can communicate max. 256 bytes data (maximum data length of the PCL device will be 8 byte communication).

Suppose that all of the local devices connected to the center device as PCL devices (G9003), 64 axes can be controlled by serial communication.

2. Features

- Maximum data transfer speed is 20 Mbps.
- Transfer cycle time is less than 1 msec when 64 local devices are connected (in case of cyclic communication only).
- One center device can connect up to 256 ports (2048 bits) for I/O connection.
- The center device provides input interrupt function to a CPU.
- Local devices are classified into the following devices:
 - * "I/O device" dedicated to control I/O port
 - * "PCL device" to generate pulse strings.
 - * "CPU emulation device" to control data communication between CPUs and other peripheral equipment.
- Local devices are allocated device numbers (0 to 63) with hardware. These device numbers can be assigned at random in a Motionnet system. Further, by system communication, device numbers can automatically be allocated.
- The center device is integrated with a memory for I/O ports. Thus, the center device can operate I/O status just like accessing normal memories.
- The center device is integrated with four types of CPU-I/F circuits (Z80, 8086, H8, 68000, etc.). As it applies for typical CPU interfaces, it will offer wide possibility to interface with a variety of CPUs.
- The center device normally uses 512 bytes area as address area. However, if resource is shorted, it can use 8-byte areas.
- Input 3.3 V single power as power supply.
However, the major terminals can be connected to devices that run with 5 V.

3. General specifications

3-1. Communication system specifications

Item	Description
Reference clock Note 1	40 MHz or 80 MHz
Communication speed Note 2	2.5 M, 5 M, 10 M, or 20 Mbps
Communication sign	NRZ sign
Communication protocol	NPM original method
Communication method	Half-duplex communication
Communication I/F Note 3	RS-485 or pulse transfer
Connection method	Multi-drop connection
Number of local devices	64 devices max.
Cyclic communication cycle when 20 Mbps Note 4	When using 8 local devices (IN: 128 points, OUT: 128 points) --- 0.12 msec. When using 16 local devices (IN: 256 points, OUT:256 points) --- 0.24 msec. When using 32 local devices (IN: 512 points, OUT: 512 points) --- 0.49 msec. When using 64 local devices (IN: 1024 points, OUT: 1024 points) --- 0.97 msec.

Note 1: When transferring data with 20 Mbps speed, and if the clock duty can be maintained to ideal "50:50" condition, the center device can be operated by inputting 40 MHz clock signal. The above ideal conditions mean that an oscillator and the center device are connected as 1:1 and close to each other. (Actually, even these conditions cannot establish 50:50. However, a duty approximate to the ideal one will be established. Even if the ideal duty is broken a little, when signal lines are shorter and/or the number of local devices is smaller, the center device can operate without any trouble. (For the details, see the section for the "CLK" terminal.)
When the signal lines are longer and/or the number of connected local devices is greater and if it is difficult to warranty the clock duty, you should take measures such as preparing an 80 MHz signal or preparing a 40 MHz clock proprietary to the center device.
To select clock rate, specify using the LSI terminal. In either clock rate, the maximum speed of 20 Mbps is the same.

Note 2: Select the communication speed using the LSI terminal. Regardless of the selection of the communication speed, the reference clock remains the same.

Note 3: NPM recommends using a system with a pulse transformer.

Note 4: The number of I/O ports in the parenthesis is true when the all the connected local devices are connected as I/O device.

When data devices are connected such as PLC device, the number of available I/O points will be decreased. However, basic cyclic cycle (alt. frequency) does not change. (When the center device communicates data, the frequency will be changed. For this matter, see the "Calculation of communication time" in this manual.

3-2. Center device specifications (G9001)

Item	Description																																	
Address area	Normally it uses 512 bytes area (A0 to A8). However, 8 bytes area (A0 to A2) can be used when using the I/O buffer (Note).																																	
Address map	<table border="1"> <thead> <tr> <th>Address (h)</th> <th>Writing</th> <th>Reading</th> </tr> </thead> <tbody> <tr> <td>000 to 001</td> <td>Command</td> <td>Status</td> </tr> <tr> <td>002 to 003</td> <td>Invalid</td> <td>Interrupt status</td> </tr> <tr> <td>004 to 005</td> <td>I/O buffer</td> <td>I/O buffer</td> </tr> <tr> <td>006 to 007</td> <td>Data sending FIFO</td> <td>Data receiving FIFO</td> </tr> <tr> <td>008 to 077</td> <td>Not specified (112 bytes)</td> <td>Not specified (112 bytes)</td> </tr> <tr> <td>078 to 0B7</td> <td>Device information (8 bits / device)</td> <td>Device information (8 bits / device)</td> </tr> <tr> <td>0B8 to 0BF</td> <td>Reset I/O communication error flag</td> <td>I/O communication error flag</td> </tr> <tr> <td>0C0 to 0DF</td> <td>Set input port change interrupt</td> <td>Set input port change interrupt</td> </tr> <tr> <td>0E0 to 0FF</td> <td>Reset input port change interrupt flag</td> <td>Input port change interrupt flag</td> </tr> <tr> <td>100 to 1FF</td> <td>I/O port data</td> <td>I/O port data</td> </tr> </tbody> </table>	Address (h)	Writing	Reading	000 to 001	Command	Status	002 to 003	Invalid	Interrupt status	004 to 005	I/O buffer	I/O buffer	006 to 007	Data sending FIFO	Data receiving FIFO	008 to 077	Not specified (112 bytes)	Not specified (112 bytes)	078 to 0B7	Device information (8 bits / device)	Device information (8 bits / device)	0B8 to 0BF	Reset I/O communication error flag	I/O communication error flag	0C0 to 0DF	Set input port change interrupt	Set input port change interrupt	0E0 to 0FF	Reset input port change interrupt flag	Input port change interrupt flag	100 to 1FF	I/O port data	I/O port data
Address (h)	Writing	Reading																																
000 to 001	Command	Status																																
002 to 003	Invalid	Interrupt status																																
004 to 005	I/O buffer	I/O buffer																																
006 to 007	Data sending FIFO	Data receiving FIFO																																
008 to 077	Not specified (112 bytes)	Not specified (112 bytes)																																
078 to 0B7	Device information (8 bits / device)	Device information (8 bits / device)																																
0B8 to 0BF	Reset I/O communication error flag	I/O communication error flag																																
0C0 to 0DF	Set input port change interrupt	Set input port change interrupt																																
0E0 to 0FF	Reset input port change interrupt flag	Input port change interrupt flag																																
100 to 1FF	I/O port data	I/O port data																																
Communication data length	1 to 128 word/frame (1 word = 16 bits)																																	
Data communication time	When communicating 3 words (write 1 register of PCL) --- 19.3 μ s When communicating 128 words --- 168.1 μ s																																	
CPU-I/F	Integrated 4 types of CPU-I/F circuit (Z80, 8086, H8, 68000 etc.)																																	
Transfer method	Cyclic transfer for I/O port, transit transfer for data communication																																	
Package	64-pin QFP (model section: 10 x 10 x 1.4 mm)																																	
Power source	3.3 V \pm 10%																																	
Storage temperature range	-65 to +150 $^{\circ}$ C																																	
Operating temperature range	-40 to +85 $^{\circ}$ C																																	

Note: By issuing an operation command to the center device, you can access the entire address area through a single I/O buffer. (It will take more time than direct access.)
Required address area is only 8-bytes (3 address signals).
For concrete use example, see the software examples in chapter IV.

4. Hardware description

4-1. A list of terminals (QFP-64)

	Signal name	I/O	Logic	Description	5V interface
1	IFO	I	-	CPU-I/F mode setting bit 0	Available
2	IF1	I	-	CPU-I/F mode setting bit 1	Available
3	CS	I	Negative	Select chip	Available
4	WR	I	Negative	Write	Available
5	RD	I	Negative	Read	Available
6	A0	I	Positive	Address bus bit 0 (LSB)	Available
7	A1	I	Positive	Address bus bit 1	Available
8	A2	I	Positive	Address bus bit 2	Available
9	A3	I	Positive	Address bus bit 3	Available
10	GND	I		GND	
11	A4	I	Positive	Address bus bit 4	Available
12	A5	I	Positive	Address bus bit 5	Available
13	A6	I	Positive	Address bus bit 6	Available
14	A7	I	Positive	Address bus bit 7	Available
15	A8	I	Positive	Address bus bit 8	Available
16	VDD	I		+3.3 V power input	
17	D0	B	Positive	Data bus bit 0 (LSB)	Available
18	D1	B	Positive	Data bus bit 1	Available
19	D2	B	Positive	Data bus bit 2	Available
20	D3	B	Positive	Data bus bit 3	Available
21	GND	I		GND	
22	D4	B	Positive	Data bus bit 4	Available
23	D5	B	Positive	Data bus bit 5	Available
24	D6	B	Positive	Data bus bit 6	Available
25	D7	B	Positive	Data bus bit 7	Available
26	VDD	I		+3.3 V power input	
27	D8	B	Positive	Data bus bit 8	Available
28	D9	B	Positive	Data bus bit 9	Available
29	D10	B	Positive	Data bus bit 10	Available
30	D11	B	Positive	Data bus bit 11	Available
31	GND	I		GND	
32	D12	B	Positive	Data bus bit 12	Available
33	D13	B	Positive	Data bus bit 13	Available
34	D14	B	Positive	Data bus bit 14	Available
35	D15	B	Positive	Data bus bit 15	Available
36	VDD	I		+3.3 V power input	
37	INT	O	Negative	Interrupt request	Available
38	WRQ	O	Negative	Wait request	Available
39	IFB	O	Negative	CPU-I/F is busy	Available
40	MCRY	O	Negative	By detecting a communication line signal, this signal becomes L for a rated interval.	Available
41	MERR	O	Negative	When received an error frame and no response, this signal becomes L level for a rated interval.	Available
42	GND	O		GND	
43	MERF	O	Negative	When receiving an error response frame, this signal becomes L level for a rated interval.	Available
44	MSYN	O	Negative	The level reverses at each cyclic cycle.	Available
45	SOEL	O	Negative	Enable serial output	
46	SOEH	O	Positive	Enable serial output	

	Signal name	I/O	Logic	Description	5V interface
47	SO	O	Positive	Serial output	
48	VDD	I		+3.3 V power input	
49	SPD0	I	-	Communication speed setting bit 0	Available
50	SPD1	I	-	Communication speed setting bit 1	Available
51	SIA	I	Positive	Serial input A	
52	GND	I		GND	
53	VDD	I		+3.3 V power input	
54	SIB	I	Positive	Serial input B	
55	GND	I		GND	
56	CKSL	I		Clock selection (L: 40 MHz, H: 80 MHz)	Available
57	GND	I		GND	
58	CLK	I	-	Reference clock	
59	VDD	I		+3.3 V power input	
60	GND	I		GND	
61	GND	I		GND	
62	GND	I		GND	
63	RST	I	Negative	Reset	
64	VDD	I		+3.3 V power input	

Note 1: "I" in the I/O column is for input, "O" is output, and "B" is both directions.

Note 2: As for the terminals with "available" in the 5V interface column, note the following.

- * These terminals can be input at 5 V level signal. These are deleted diodes for overcurrent protection on 3.3 V lines. If over voltage may be possible to charge due to reflection, linking, or inductive noise, we recommend inserting a diode for overcurrent protection.

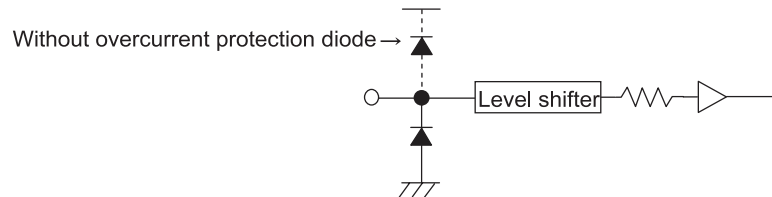

- * Outputs from 5V devices can be connected to the center device as far as these are TTL level. (Even if a signal is pulled up to 5V, the output level will be less than 3.3 V.) However, CMOS level signals cannot be connected.
- * On the CPU bus interface, pull up of 5 V level is possible for stabilizing bus lines (prevent floating). Use 10 k-ohm or larger capacity pull up resistors.

4-2. Terminal allocation diagram

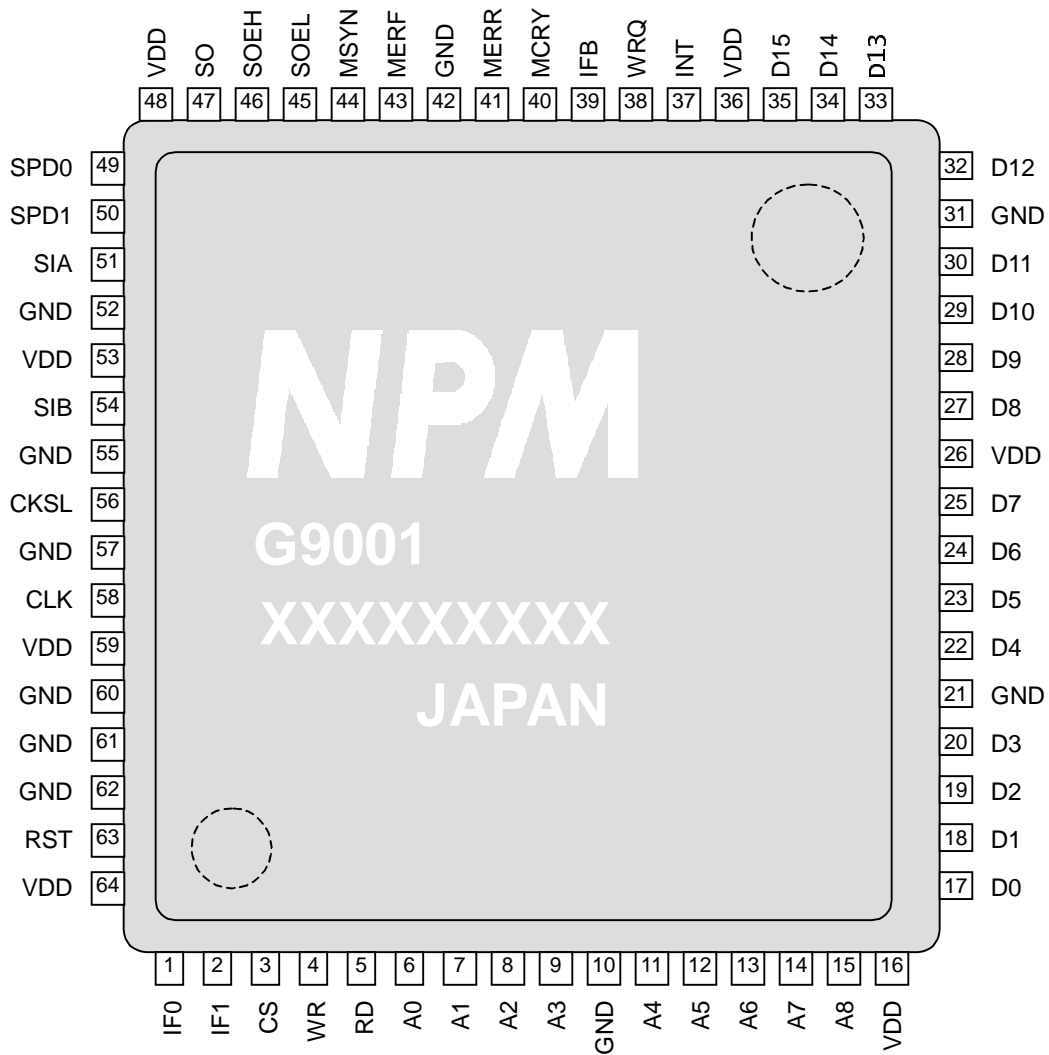

Note: For each pin number, see the marks on the actual LSI.
 As shown above, to the lower left of the NPM logo mark is the 1st pin.

4-3. Entire block diagram

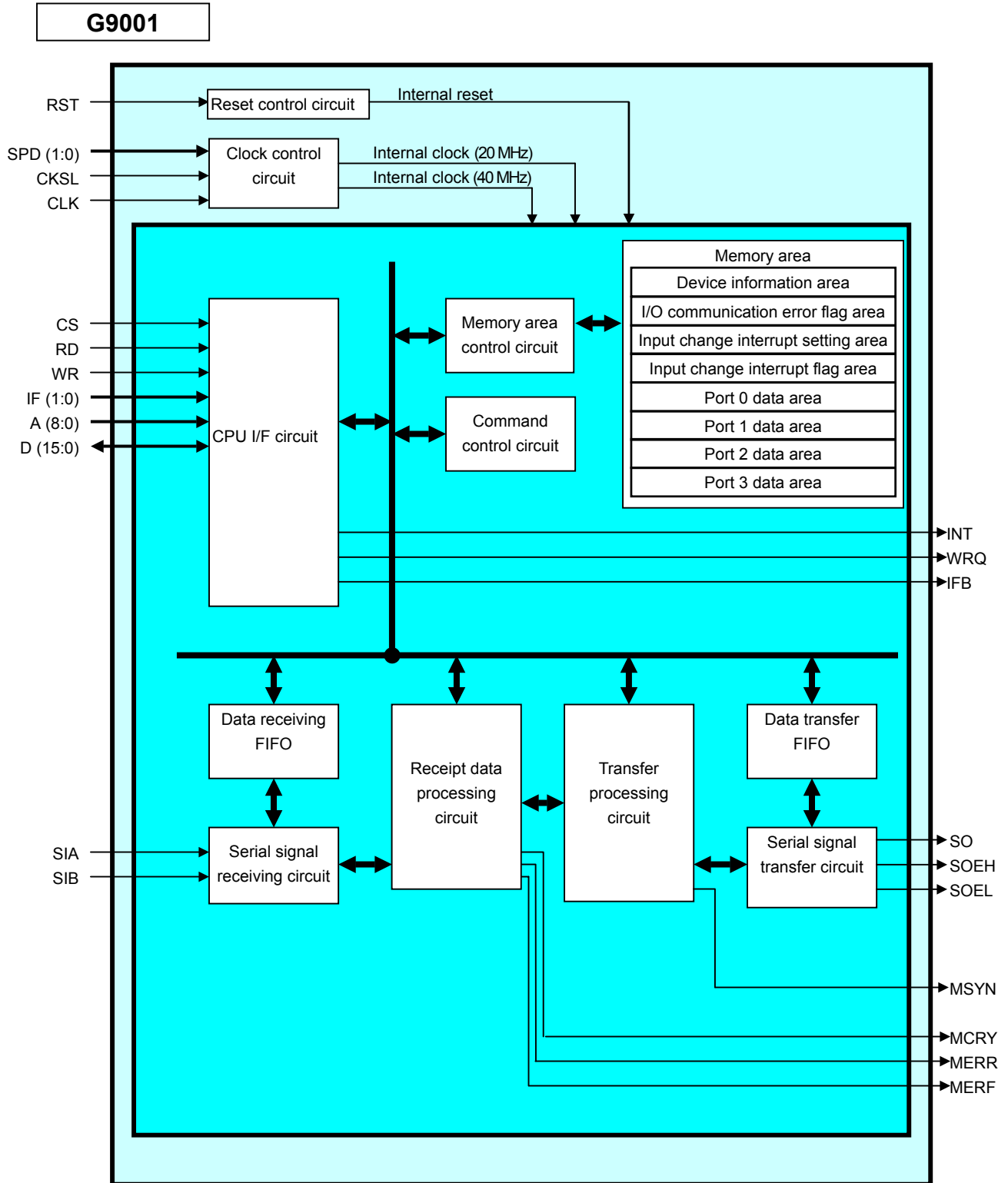

4-4. Functions of terminals

4-4-1. CLK

This is an input terminal of the reference clock. By setting of the CKSL terminal, either of the following clock rate signals can be connected.

CKSL = L: 40 MHz

CKSL = H: 80 MHz

By selecting either of these clock rates, the serial communication transfer rate does not change. This clock rate selection affects communication precision.

For a small-scale serial communication and transfer rate below 10 Mbps, use of the center device with 40 MHz does not give any restriction.

With 20 Mbps transfer speed; however, longer communication lines or a large number of connected local devices may deteriorate communication precision due to collapse of signals on the circuit. This deterioration of communication quality can be corrected inside the LSI, if the deterioration level is not much. In order to improve correction precision; however, evenness of the clock duty is required. In other words, if the duty is ideal (50:50), the capacity to correct collapse of the signals in the communication lines can be improved. On the contrary, if the duty is not ideal, the center device cannot cope with collapses of the communication line.

As a result, if the duty is close to ideal, the center device can be used with 40 MHz. When connecting more than one oscillator, the duty will not be ideal. In this case, select 80 MHz. The central device divides the frequency inside and creates 40 MHz frequency. If you do not want 80 MHz frequency, you may prepare a separate 40 MHz oscillator for this LSI.

4-4-2. RST

This is an input terminal for a reset signal.

By inputting an L level signal, the central device is reset. As the central device synchronizes with a clock, arrange a circuit so that it does not disconnect the clock while resetting. Reset signal length longer than 10 clock cycles is required.

4-4-3. CKSL

Use to select clock rate.

L: Connect 40 MHz clock frequency to the CLK terminal.

H: Connect 80 MHz clock frequency to the CLK terminal.

Select this when the duty of the 40 MHz clock collapses too much.

4-4-4. IF0, IF1

Specify CPU-I/F mode

Set status		I/F mode	CPU signal to connect to terminals				Example of CPU
IF1	IF2		RD terminal	WR terminal	A0 terminal	WRQ terminal	
L	L	I/F mode 1	(VDD)	R/W	$\overline{\text{LDS}}$	$\overline{\text{DTACK}}$	68000
L	H	I/F mode 2	$\overline{\text{RD}}$	$\overline{\text{HWR}}$	(VDD)	$\overline{\text{WAIT}}$	H8
H	L	I/F mode 3	$\overline{\text{RD}}$	$\overline{\text{WR}}$	(GND)	READY	8086
H	H	I/F mode 4	$\overline{\text{RD}}$	$\overline{\text{WR}}$	A0	$\overline{\text{WAIT}}$	Z80

This LSI has the following four interface modes.

The above four CPUs are typical ones among CPUs currently available on the market. Even if a CPU you are examining is other than the above CPUs, most of the CPUs can be connected using either of the interfaces above. For details, see the hardware specification sheets of the CPU you are planning to use, and check with which mode you can connect.

Note: The classification of the CPU interface modes above is applicable only for the center device. The CPU emulation device G9004 also has unique CPU interface modes. Mode classification of this is different than the above.

4-4-5. CS

Input L level signal to this terminal when accessing this LSI.

4-4-6. RD, WR, A0, and WRQ

Connect I/F signals with a CPU. Input signals vary with setting of the IF0 to 1. For the details, see items "IF0 and IF1."

4-4-7. INT

Outputs an interrupt request signal.
When not using this terminal, keep this terminal open.

4-4-8. IFB

Use this terminal when connecting with a CPU having no wait control input terminal. By reading a command from a CPU, this signal becomes L level. When the command process is complete, this signal returns to H level. After confirming that this terminal is H level, access the center device.

4-4-9. A1 to A8

Enter address signal to these terminals.
When the IF1 is L, address bus A1 to A8 are inverted inside.
When to control at 8-byte area, process as follows:

IF1 terminal status	A (8:3) process	Remarks
H	Pull up (set to H)	I/F mode 1, 2
L	GND (set to L)	I/F mode 3, 4

4-4-10. D0 to D7

Connect lower 8 bits of the data bus.

4-4-11. D8 to D15

Connect upper 8 bits of the data bus.
 When used as I/F mode 4 (IF1 = H, IF0 = H), pull up or pull down with 5 to 10 K-ohms resistor.
 (Use of one resistor for 8 lines is also available.)

4-4-12. SPD0, SPD1

Specify communication speed with these terminals.

SPD1	SPD0	Communication speed
L	L	2.5 Mbps
L	H	5 Mbps
H	L	10 Mbps
H	H	20 Mbps

All of the devices on the communication line shall be set to the same speed.
 Either 40 MHz or 80 MHz is connected to the clock signal, as far as you do not mistake setting of the "CKSL," you can get communication speed of 20 Mbps.

4-4-13. SO

Serial output signal for communication. (Positive logic)
 Connect this line to a data input of a RS485 device.

4-4-14. SOEH, SOEL

Output enable signal for communication.
 Difference between SOEH and SOEL is that only logic is different.
 When sending signals, SOEH will become H and SOEL will become L.
 Connect either of needed signal to the data enabled input of a RS485 device.

4-4-15. SIA, SIB

Serial input signals for communication. (Positive logic)
 Basically these two are identical in functions.
 Each of them can construct independent signal line as follows.

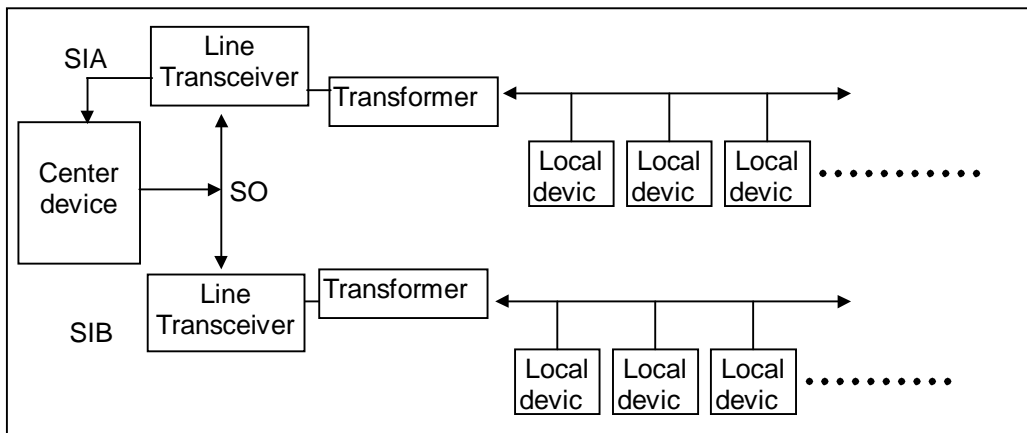

Commonly using the serial output signal "SO" from the center device, provide RS485 and pulse transformer individually for each line, the signal line load can be decreased.
 When connecting to many local devices on one line, or when a signal line is long, signal quality will be deteriorated remarkably. In order to prevent this problem, separate to two lines.
 Even divided into two lines, use easiness from a CPU is identical.
 One line can connect to max. 64 devices. Even when two lines are used, the max. number of devices is 64.

4-4-16. MCRY

This is a monitor output to confirm communication.

When a signal is transferred on the signal line, this terminal outputs L signal. If there is no signal on the signal line, this terminal outputs H signal.

4-4-17. MERR

This is a monitor output to check communication quality.

When the center device receives an error frame such as a CRC error, or when it cannot receive a response frame within 20 μ s, the signal becomes L only for 128 cycles (3.2 μ s) of the CLK.

By measuring the condition using the counter, you can check communication quality.

4-4-18. MERF

This is a monitor terminal to confirm communication control status.

When the center device receives an error response frame, this terminal outputs L level signal only for 0.2 seconds.

The error response frame is as follows:

A local device normally receives signals from the center device if there is no CRC error on the local device.
However, it may possible that the received data do not match with the local device status (such as receiving output data on the input port).
In this case, the local device sends back the data to the center device in order to notify the center device that the received data is useless.
This is error response frame.

Other case is that a local device sends data longer than 8 bytes to a PCL device (8 bytes FIFO), and the PCL device returns receipt process error (format error).

4-4-19. MSYN

This is a monitor output of cyclic communication cycle.

Each time a cyclic communication cycle ends, this signal level changes between L and H.

4-5. Address map

Address map (1) I/F mode 4 (Please be aware of Notes 1 and 2 while accessing)

A0 to A8		Writing		Reading	
0 0000 0000	000h	Command bits 0 to 7	Note 1	Status bits 0 to 7	
0 0000 0001	001h	Command bits 8 to 15	Note 1	Status bits 8 to 15	
0 0000 0010	002h	Invalid		Interrupt status bits 0 to 7	
0 0000 0011	003h	Invalid		Interrupt status bits 8 to 15	
0 0000 0100	004h	Input/output buffer bits 0 to 7		Input/output buffer bits 0 to 7	
0 0000 0101	005h	Input/output buffer bits 8 to 15		Input/output buffer bits 8 to 15	
0 0000 0110	006h	Data transfer FIFO bits 0 to 7	Note 1	Data receiving FIFO bits 0 to 7	Note 2
0 0000 0111	007h	Data transfer FIFO bit 8 to 15	Note 1	Data receiving FIFO bits 8 to 15	Note 2
0 0000 1000 0 0111 0111	008h 077h	Not defined (112 bytes) (Any data written here will be ignored.)		Not defined (112 bytes) (Always read as 00h.)	
0 0111 1000	078h	Device information (Device No. 0)		Device information (Device No.0)	
0 0111 1001	079h	Device information (Device No. 1)		Device information (Device No.1)	
0 1011 0110	0B6h	Device information (Device No. 62)		Device information (Device No.62)	
0 1011 0111	0B7h	Device information (Device No. 63)		Device information (Device No.63)	
0 1011 1000	0B8h	I/O communication error flags (Device No. 0 to 7)		I/O communication error flags (Device No. 0 to 7)	
0 1011 1001	0B9h	I/O communication error flags (Device No. 8 to 15)		I/O communication error flags (Device No. 8 to 15)	
0 1011 1110	0BEh	I/O communication error flags (Device No. 48 to 55)		I/O communication error flags (Device No. 48 to 55)	
0 1011 1111	0BFh	I/O communication error flags (Device No. 56 to 63)		I/O communication error flags (Device No. 56 to 63)	
0 1100 0000	0C0h	Input change interrupt settings (Device No. 0, 1)		Input change interrupt settings (Device No. 0 to 1)	
0 1100 0001	0C1h	Input change interrupt settings (Device No. 2, 3)		Input change interrupt settings (Device No. 2, 3)	
0 1101 1110	0DEh	Input change interrupt settings (Device No. 60, 61)		Input change interrupt settings (Device No. 60, 61)	
0 1101 1111	0DFh	Input change interrupt settings (Device No. 62, 63)		Input change interrupt settings (Device No. 62, 63)	
0 1110 0000	0E0h	Input change interrupt flags (Device No. 0, 1)		Input change interrupt flags (Device No. 0, 1)	
0 1110 0001	0E1h	Input change interrupt flags (Device No. 2, 3)		Input change interrupt flags (Device No. 2, 3)	
0 1111 1110	0FEh	Input change interrupt flags (Device No. 60, 61)		Input change interrupt flags (Device No. 60, 61)	
0 1111 1111	0FFh	Input change interrupt flags (Device No. 62, 63)		Input change interrupt flags (Device No. 62, 63)	

1 0000 0000	100h	Port data No. 0 (Device No.0 - Port 0)	Port data No. 0 (Device No.0 - Port 0)
1 0000 0001	101h	Port data No. 1 (Device No.0 - Port 1)	Port data No. 1 (Device No.0 - Port 1)
1 0000 0010	102h	Port data No. 2 (Device No.0 - Port 2)	Port data No. 2 (Device No.0 - Port 2)
1 0000 0011	103h	Port data No. 3 (Device No.0 - Port 3)	Port data No. 3 (Device No.0 - Port 3)
1 1111 1100	1FCh	Port data No. 252 (Device No.63 - Port 0)	Port data No. 252 (Device No.63 - Port 0)
1 1111 1101	1FDh	Port data No. 253 (Device No.63 - Port 1)	Port data No. 253 (Device No.63 - Port 1)
1 1111 1110	1FEh	Port data No. 254 (Device No.63 - Port 2)	Port data No. 254 (Device No.63 - Port 2)
1 1111 1111	1FFh	Port data No. 255 (Device No.63 - Port 3)	Port data No. 255 (Device No.63 - Port 3)

Note 1: Write in lower bit to upper bit order.

This order is especially important when accessing the FIFO used exclusively for sending data.

Note 2: Read in lower bit to upper bit order.

This order is especially important when accessing the FIFO used exclusively for receiving data.

Address map (2) I/F mode 3

A1 to A8		Writing	Reading
0 0000 000	000h	Command bits 0 to 15	Status bits 0 to 15
0 0000 001	002h	Invalid	Interrupt status bits 0 to 15
0 0000 010	004h	Input/output buffer bits 0 to 15	Input/output buffer bits 0 to 15
0 0000 011	006h	Data transfer FIFO bits 0 to 15	Data receiving FIFO bits 8 to 15
0 0000 100 0 0111 011	008h 076h	Not defined (56 words) (Any data written here will be ignored.)	Not defined (56 words) (Always read as 00h.)
0 0111 100 	078h 	Device information (Device No. 0, 1)	Device information (Device No.0, 1)
0 1011 011	0B6h	Device information (Device No. 62, 63)	Device information (Device No.62, 63)
0 1011 100 	0B8h 	I/O communication error flags (Device No. 0 to 15)	I/O communication error flags (Device No. 0 to 15)
0 1011 111	0BEh	I/O communication error flags (Device No. 48 to 63)	I/O communication error flags (Device No. 48 to 63)
0 1100 000 	0C0h 	Input change interrupt settings (Device No. 0 to 3)	Input change interrupt settings (Device No. 0 to 3)
0 1101 111	0DEh	Input change interrupt settings (Device No. 60 to 63)	Input change interrupt settings (Device No. 60 to 63)
0 1110 000 	0E0h 	Input change interrupt flags (Device No. 0 to 3)	Input change interrupt flags (Device No. 0 to 3)
0 1111 111	0FEh	Input change interrupt flags (Device No. 60 to 63)	Input change interrupt flags (Device No. 60 to 63)
1 0000 000	100h	Port data No. 0, 1 (Device No.0 - Port 0, 1)	Port data No. 0, 1 (Device No.0 - Port 0, 1)
1 0000 001 	102h 	Port data No. 2, 3 (Device No.0 - Port 2, 3)	Port data No. 2, 3 (Device No.0 - Port 2, 3)
1 1111 110	1FCh	Port data No. 252, 253 (Device No.63 - Port 0, 1)	Port data No. 252,253 (Device No.63 - Port 0, 1)
1 1111 111	1FEh	Port No.254, 255 (Device No.63 - Port 2, 3)	Port data No. 254, 255 (Device No.63 - Port 2, 3)

Note: The hexadecimal notation for the addresses above are written with the assumption that A0 = 0.

Address map (3) I/F mode 1, 2

A1 to A8		Writing	Reading
1 1111 111	1FFh	Command bits 0 to 15	Status bits 0 to 15
1 1111 110	1FCh	Invalid	Interrupt status bits 0 to 15
1 1111 101	1FAh	Input/output buffer bits 0 to 15	Input/output buffer bits 0 to 15
1 1111 100	1F8h	Data transfer FIFO bits 0 to 15	Data receiving FIFO bits 8 to 15
1 1111 011 1 1000 100	1F6h 188h	Not defined (56 words) (Any data written here will be ignored.)	Not defined (56 words) (Always read as 00h.)
1 1000 011	186h	Device information (Device No. 0, 1)	Device information (Device No.0, 1)
1 0100 100	148h	Device information (Device No. 62, 63)	Device information (Device No.62, 63)
1 0100 011	146h	I/O communication error flags (Device No. 0 to 15)	I/O communication error flags (Device No. 0 to 15)
1 0100 000	140h	I/O communication error flags (Device No. 48 to 63)	I/O communication error flags (Device No. 48 to 63)
1 0011 111	13Eh	Input change interrupt settings (Device No. 0 to 3)	Input change interrupt settings (Device No. 0 to 3)
1 0010 000	120h	Input change interrupt settings (Device No. 60 to 63)	Input change interrupt settings (Device No. 60 to 63)
1 0001 111	11Eh	Input change interrupt flags (Device No. 0 to 3)	Input change interrupt flags (Device No. 0 to 3)
1 0000 000	100h	Input change interrupt flags (Device No. 60 to 63)	Input change interrupt flags (Device No. 60 to 63)
0 1111 111	0FEh	Port data No. 0, 1 (Device No.0 - Port 0, 1)	Port data No. 0, 1 (Device No.0 - Port 0, 1)
0 1111 110	0FCh	Port data No. 2, 3 (Device No.0 - Port 2, 3)	Port data No. 2, 3 (Device No.0 - Port 2, 3)
0 0000 001	002h	Port data No. 252, 253 (Device No.63 - Port 0, 1)	Port data No. 252,253 (Device No.63 - Port 0, 1)
0 0000 000	000h	Port No.254, 255 (Device No.63 - Port 2, 3)	Port data No. 254, 255 (Device No.63 - Port 2, 3)

Note: The hexadecimal notation for the addresses above are written with the assumption that A0 = 0.

Note: The discussion of address maps below largely concerns I/F mode 3.

4-5-1. "Device information" area

With system communication, the central device polls all local devices, from device 0 to 63. According to the response from local devices, the central device can confirm the connection status, device type, settings for the I/O port on each local device, and refresh its own "device information" area.

When a CPU knows the "device information", the central device can write to it. 8 bits of device information are required for each device.

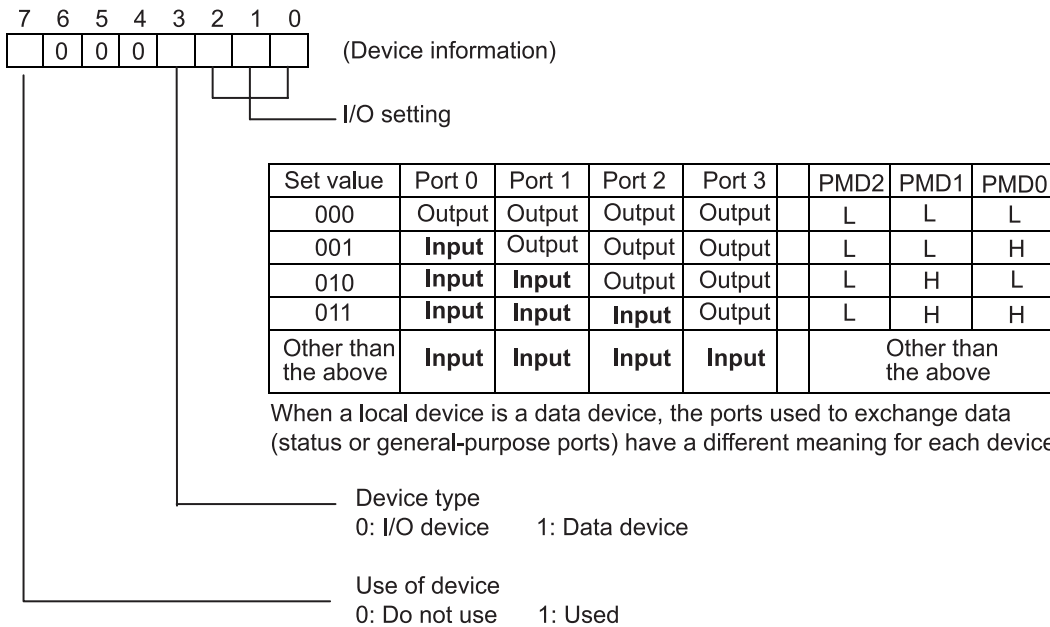

Ex.: To get device information for device Nos. 0 and 1, access address 078h. For a 16-bit CPU (address = 078h)

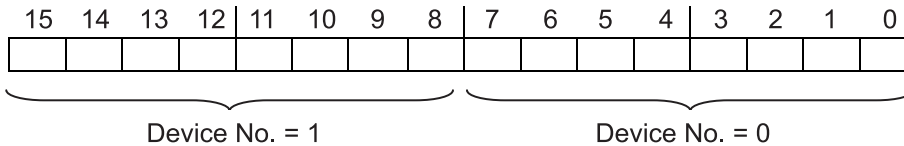

4-5-2. "I/O communication area flags"

The central device communicates with all the I/O ports using cyclic communication. In this type of cyclic communication, if a communication error occurs for a specific I/O device on three consecutive communication cycles, the central device will treat this as an I/O communication error.

When this error occurs, the bit in this area corresponding to the device number will become 1. By checking these bits, you can identify the I/O device in error.

Ex.: When reading address 0B8h

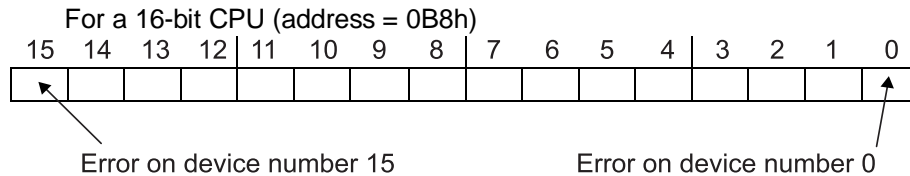

As seen above, the lowest bit shows the error status of the local device with the lowest address number. By reading "0B8h," local device numbers from 0 to 15 can be checked. In the same way, by reading "BAh" you can check device numbers 16 to 31.

To determine the address, proceed as follows. (discard any remainder)

Address = 0B8h + (Device No. / 8)

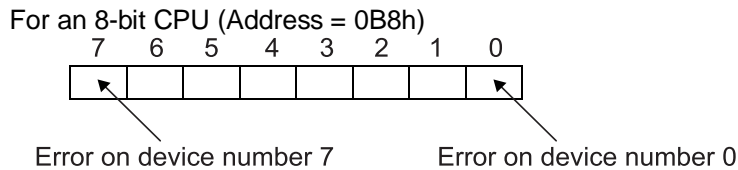

The bits are read in groups of 8 by an 8-bit CPU, but the meaning of each bit is the same.

The device number refers to the number allocated to each local device. The numbers are specified on the external terminals on local devices. Duplicate use of the same number is prohibited.

- To clear flags

In order to return a bit to 0 that was changed to a 1 when an error occurred, write a 1 to this bit.

The simplest way to clear a flag is to write the same data back to the same I/O communication error flag position that it was read from.

(For examples of how to use these flags, see point (2) in the "Check and Clear I/O Communication Errors" in "Software examples" in Chapter IV.

4-5-3. "Change to Input Port Interrupt Setting" area

Port information for the I/O devices that are connected can be obtained automatically using the cyclic communication system. The central device also uses cyclic communication to periodically obtain status information for the data devices that are connected.

These changes to input ports and status changes in data devices can be detected automatically, and then the central device can generate an interrupt (INT) for a CPU.

This area can be addressed by writing bits that correspond to the local device number whose status you want to monitor. When a bit is set to "1" its status will be monitored

Ex.: When you want to monitor port 2 on device number 0.

In order to specify device number 0, you have to access address 0C0h.

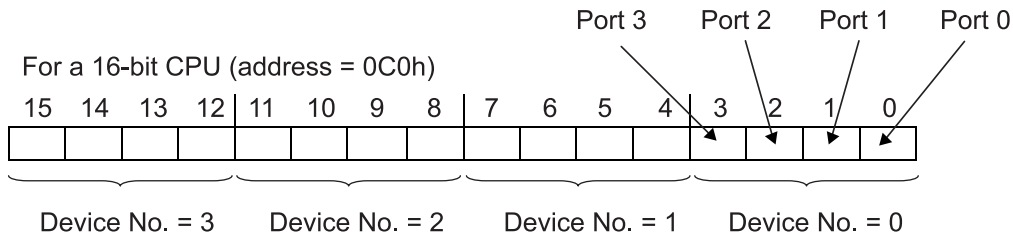

As shown above, there are 4 bits which correspond to each local device. The lowest 4 bits will be the area for setting up interrupts for the local device with the lowest address number.

The lowest of the 4 bits corresponds to port 0, the next bit corresponds to port 1, and so forth. When you want to monitor another local device, determine the address using the following rule (discard any remainder).

$$\text{Address} = 0C0h + (\text{device number} / 2)$$

The rule is the same for an 8-bit CPU, except that the data will be transferred in units of 8 bits.

Since mainly status information corresponds to each port on data devices, you just enter a "1" for the port which has the status you want to monitor.

For details, see "5-1-3. Change to Input Interrupts." (Be especially careful when monitoring the status of a device to make sure that port 0 is not monitoring all the bits.)

For details about which status information corresponds to which port, see the user's manual for each data device.

(For examples of use, see point (2) in the "Change-In-Input Interrupt Setting" section of "Software Examples" in Chapter IV.)

4-5-4. "Change-In-Input Interrupt Flag" area

If a port has been specified in the area for setting Change-In-Input Interrupts, when its port status changes, the central device will issue an interrupt to a CPU and change the bit to a "1."
The interrupt allows the CPU to determine the device number and port number (or status) which changed by reading this area.

Ex.: To monitor port 2 on device number 0

To read the status of device number 0 you must access address 0E0h.

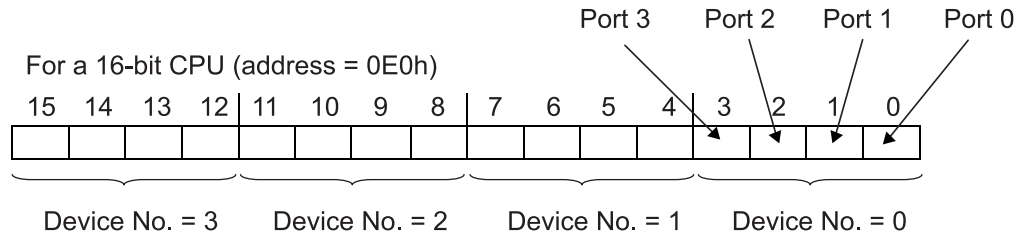

4 bits correspond to each local device. The lower 4 bits are the Input Interrupt Setting area of the local device with the lowest address number.

The lowest bit among these 4 corresponds to port 0, the next bit corresponds to port 1, and so forth.

To check other local devices, specify the address by using the following rule (discard any remainder).

$$\text{Address} = 0E0h + (\text{device number} / 2)$$

The procedure is the same for an 8-bit CPU, except that data will be handled in units of 8 bits.

- To clear flags

In order to return a bit to 0 that was changed to a 1 when a change occurred in the input, write a 1 to this bit.

The simplest way to clear a flag is to write the same data back to the same "input change interrupt flag" area that it was read from.

(For examples of use, see point (2) in the "Change-In-Input Interrupt Setting" section of "Software Examples" in Chapter IV.)

4-5-5. "Port data" area

This area is used primarily to set the data for output ports on I/O devices, and to check the data from the input ports.

When the local device is a data device, this area is used to read status information and set data for the general-purpose port (if any needs to be set).

To access this area, see the device number and port number described in the address map.

To learn which status register corresponds to which port when the local device is a data device, see the user manual for that device.

(For examples of use, see point (2) in the "Change-In-Input Interrupt Setting" section of "Software Examples" in Chapter IV.)

4-6. Status

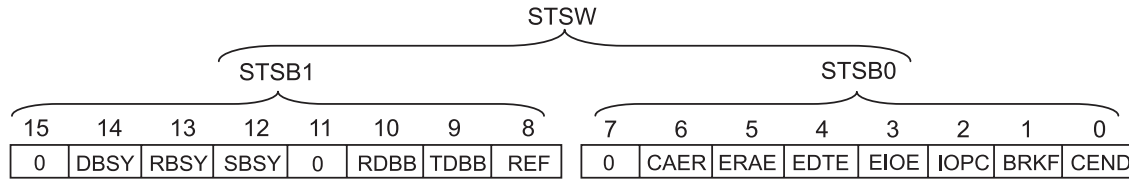

Bit	Symbol	Description
0	CEND	Becomes 1 when ready for data to be written to the transmitting FIFO buffer. When the system communication or data communication is complete and the next chunk of data can be sent to the transmitting FIFO buffer, this bit becomes 1 and the central device outputs an interrupt signal (INT). Once the status of this bit is read it returns to 0.
1	BRKF	When the central device receives a break frame this bit becomes 1 and an interrupt signal (INT) is output. Once the status of this bit is read it returns to 0.
2	IOPC	Becomes 1 when any input port which had enabled the "input change interrupt setting" and that status changed. The central device then outputs an interrupt signal (INT). This signal is an OR of all 256 "input port change interrupt flag" bits. When all the bits return to 0, this bit returns to 0.
3	EIOE	Becomes 1 when an I/O communication error occurs. The central device then outputs an interrupt signal (INT). This signal is an OR of all 64 "I/O communication error flag" bits. When all the bits return to 0, this bit returns to 0.
4	EDTE	Becomes 1 when a data or system communication error occurs. The central device then outputs an interrupt signal (INT). Once the status of this bit is read it returns to 0.
5	ERAE	Becomes 1 when a "local device reception processing error" occurs. The central device then outputs an interrupt signal (INT). Once the status of this bit is read it returns to 0. Then, the device number and details where the reception processing error occurred can be checked by reading the interrupt status. [Note. 1]
6	CAER	A CPU access error occurred. When there is a problem accessing a CPU, such as a data send command being written when there is no data to send, this bit becomes 1. The central device then outputs an interrupt signal (INT). Once the status of this bit is read it returns to 0. The details of the error can be checked by reading the interrupt status.
7	(Not defined)	Always 0.
8	REF	When there is not-yet-sent output port data, this bit becomes 1. Write a 1 to the output port area. When cyclic communication to all the ports has completed, this bit returns to 0.
9	TDBB	When there is data to send in the transmitting FIFO, this bit becomes 1. After data is written to the transmitting FIFO, this bit becomes 1. Once a data send command or a transmitting FIFO reset command is written, this bit returns to 0.
10	RDBB	When data has been received in the receiving FIFO, this bit becomes 1. When receiving data from a data device, this bit becomes 1. After a CPU has read all of the data received, this bit returns to 0.
11	(Not defined)	Always 0.
12	SBSY	Becomes 1 when I/O communication (cyclic communication) starts.
13	RBSY	Is 1 during a reset.
14	DBSY	Is 1 during system communication or data communication.
15	(Not defined)	Always 0.

Note 1: The details of an error that occurred due to an attempt to communicate a type of information to an I/O device that is different from that called for in the PMD0 to 2 settings, can be checked by reading the interrupt status. (When errors occur on more than one device, only the device number where the last error occurred would be shown.)

4-7. Interrupt status

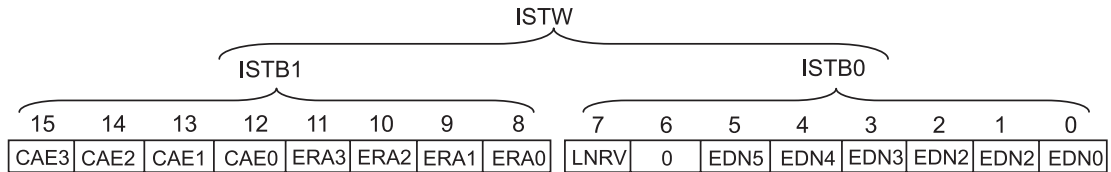

Bit	Symbol	Description
0 to 5	EDN0 to 5	Contains the device number of the device with an EDTE = 1 or ERAE = 1 (error from receiving I/O data that is different from the setting in ERA = 0001: PMD). These details are stored until the next time an error occurs.
6	(Not defined)	Always 0.
7	LNRV	When a local device is not receiving data, this bit is 1. When the data communication or system communication terminates with an error (EDTE = 1) (only when receiving attribute information), and if a local device cannot receive data from the central device, this bit becomes 1. (The local device does not respond.) When the local device has received the data, this bit returns to 0. This condition is stored until the next time an error occurs.
8 to 11	ERA0 to 3	These are identification codes for received data processing errors on a local device. The code is stored until the next time an error occurs. 0001: Received I/O data is different from the PMD settings. 0010: An I/O device received a data communication frame. (*) 0011: A data device received frames larger than the receiving buffer capacity. (*)
12 to 15	CAE0 to 3	These are access error codes from a CPU. The code is stored until the next time an error occurs. 0001: The device number was zero and an I/O communication start command was written. 0010: Tried to write data with a start sending command without any data to send. 0011: While the DBSY = 1, a device tried to do one of the following: (1) Reading or writing to the transmitting or receiving FIFO. (2) Wrote a system start command or a data communication start command. 0100: Tried to send data to a device that is not in use.

* When the ERA code is "0010" or "0011," the device number is not available in the EDN.

4-8. Command

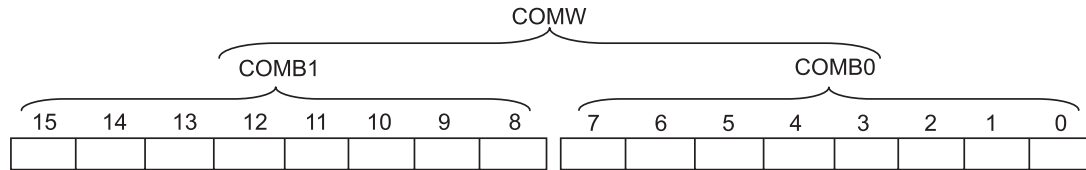

Note: Write to the 8-bit CPU I/F (IF0=H, IF1=1) in the following order: COMB0 then COMB1.

Command	Description
0000 0000 0000 0000 (0000h)	NOP Invalid command.
0000 0001 0000 0000 (0100h)	Resets the software. Resets the central device. This is the same function as the RST input.
0000 0010 0000 0000 (0200h)	Resets the transmitting FIFO. Resets only the data transmitting FIFO.
0000 0011 0000 0000 (0030h)	Resets the receiving FIFO. Resets only the data receiving FIFO.
0001 0000 0000 0000 (1000h)	System communication to all devices. Polls all of the devices (device Nos. 0 to 63) one by one, and refreshes the "device information" areas that correspond to each device number. The "device information" contains the following: - Device in use: 0 when no response, and 1 when it responds. - Device type: Reset to 1 when it is a data device. - I/O setting information
0001 0001 0000 0000 (1100h)	System communication to all devices except those devices excluded from cyclic communication. After checking the "device information" area, the central device polls all the devices whose device-in-use bit is set to 0, one by one, and refreshes the "device information" areas that correspond to each device number. The details are refreshed the same as by writing a command 1000h.
0001 0010 00## ##### (1200h to 123Fh)	System communication to specified devices. The central device polls only the specified devices and refreshes the "device information" areas that correspond to each specified device number. The details are refreshed the same as by writing a command 1000h.

Note: For all bits marked with a "#," the upper bits of the device address should be set in order, starting from the left end of the # bits.

For bits with marked with an "&," when the port is 0 or 1, set the bit to 0. When the port is 2 or 3, set the bit to 1.

For bits marked with an "x," either 0 or 1 may be used.

Command	Description																																
0001 0011 00## ##### (1300h to 133Fh)	Obtain attribute information for the specified devices. The polling response frame consists of device attribute information. This command polls the specified devices and copies the attribute information into the data receiving FIFO. The "device information" area does not change. The details of the data receiving FIFO are as follows. Bits 0 to 4: (Number of bytes for the longest piece of data) / 8 -1 Bits 5 to 7: Not used (not defined) Bits 8 to 15: Device type code (I/O device: 01h, Data device: 81h) Bits 16 to 18: Set the I/O port (PMD terminal information when an I/O device is selected) Bit 19: Always 0 Bits 20 to 31: Data device type (G9003: 000h, G9004: 001h)																																
0011 0000 0000 0000 (3000h)	Start I/O communication Start I/O communication with devices that have a 1 in the "device-in-use" bit in the "device information".																																
0011 0001 0000 0000 (3100h)	Stop I/O communication. Stop the current I/O communication.																																
0100 0000 00## ##### (4000h to 403Fh)	Data communication. Sends data in the transmitting FIFO to the specified devices. The data received in response will be stored in the receiving FIFO.																																
0100 0001 0000 0000 (4100h)	Cancel data communication Halt the data communication and reset the transmitting FIFO. This command will be ignored after the data has been sent.																																
0101 0000 0### ##xx (5000h to 507Fh)	Write to the "Device information" area. The contents of the I/O buffer are written into a word in the device information area. As an example, the relationship between the I/O buffer details and the device information area are listed below. <table border="1" style="margin-left: 20px;"> <thead> <tr> <th>Command</th> <th>I/O buffer</th> <th>Address</th> <th>Device No.</th> </tr> </thead> <tbody> <tr> <td rowspan="2">5000h</td> <td>Bit 0 to 7</td> <td>078h</td> <td>0</td> </tr> <tr> <td>Bit 8 to 15</td> <td>079h</td> <td>1</td> </tr> <tr> <td rowspan="2">5004h</td> <td>Bit 0 to 7</td> <td>07Ah</td> <td>2</td> </tr> <tr> <td>Bit 8 to 15</td> <td>07Bh</td> <td>3</td> </tr> <tr> <td rowspan="2">5008h</td> <td>Bit 0 to 7</td> <td>07Ch</td> <td>4</td> </tr> <tr> <td>Bit 8 to 15</td> <td>07Dh</td> <td>5</td> </tr> <tr> <td rowspan="2">500Ch</td> <td>Bit 0 to 7</td> <td>07Eh</td> <td>6</td> </tr> <tr> <td>Bit 8 to 15</td> <td>07Fh</td> <td>7</td> </tr> </tbody> </table> <p>Use this function when you want to reduce the number of addresses used in the central device.</p>	Command	I/O buffer	Address	Device No.	5000h	Bit 0 to 7	078h	0	Bit 8 to 15	079h	1	5004h	Bit 0 to 7	07Ah	2	Bit 8 to 15	07Bh	3	5008h	Bit 0 to 7	07Ch	4	Bit 8 to 15	07Dh	5	500Ch	Bit 0 to 7	07Eh	6	Bit 8 to 15	07Fh	7
Command	I/O buffer	Address	Device No.																														
5000h	Bit 0 to 7	078h	0																														
	Bit 8 to 15	079h	1																														
5004h	Bit 0 to 7	07Ah	2																														
	Bit 8 to 15	07Bh	3																														
5008h	Bit 0 to 7	07Ch	4																														
	Bit 8 to 15	07Dh	5																														
500Ch	Bit 0 to 7	07Eh	6																														
	Bit 8 to 15	07Fh	7																														

Note: For all bits marked with a "#," the upper bits of the device address should be set in order, starting from the left end of the # bits.

For bits marked with an "&," when the port is 0 or 1, set the bit to 0. When the port is 2 or 3, set the bit to 1.

For bits marked an "x," either 0 or 1 may be used.

G9002: I/O device

G9003: PCL device

G9004: CPU emulation device

Command	Description
0101 0001 0###x xxxx (5100h to 517Fh)	Write to the "I/O communication error flag" area. The contents of the I/O buffer are written into a word in this area. Use this function when you want to reduce the number of addresses used in this device.
0101 0010 0### #xxx (5200h to 527Fh)	Write to the "input change interrupt setting" area. The contents of the I/O buffer are written into a word in this area. Use this function when you want to reduce the number of addresses used in this device.
0101 0011 0### #xxx (5300h to 537Fh)	Write to the "input change interrupt flag" area. The contents of the I/O buffer are written into a word in this area. Use this function when you want to reduce the number of addresses used in this device.
0101 0100 0### ###& (5400h to 547Fh)	Write to the "port data" area. The contents of the I/O buffer are written into a word in this area. Use this function when you want to reduce the number of addresses used in this device.
0110 0000 0### #xxx (6000h to 607Fh)	Read the "device information" area. The contents of the word in this area are copied to the I/O buffer. Use this function when you want to reduce the number of addresses used in this device.
0110 0001 0###x xxxx (6100h to 617Fh)	Read the "I/O communication error flag" area. The contents of the word in this area are copied to the I/O buffer. Use this function when you want to reduce the number of addresses used in this device.
0110 0010 0### #xxx (6200h to 627Fh)	Read the "input change interrupt setting" area. The contents of the word in this area are copied to the I/O buffer. Use this function when you want to reduce the number of addresses used in this device.
0110 0 11 0### #xxx (6300h to 637Fh)	Read the "input change interrupt flag" area. The contents of the word in this area are copied to the I/O buffer. Use this function when you want to reduce the number of addresses used in this device.
0110 0100 0### ###& (6400h to 647Fh)	Read the "port data" area. The contents of the word in this area are copied to the I/O buffer. Use this function when you want to reduce the number of addresses used in this device.

Note: For all bits marked with a "#," the upper bits of the device address should be set in order, starting from the left end of the # bits.

For bits marked with an "&," when the port is 0 or 1, set the bit to 0. When the port is 2 or 3, set the bit to 1.

For bits marked with an "x," either 0 or 1 may be used.

If all of the address map byte (512 bytes) requested by the central device are allocated so that a CPU can see them, the commands from "5000h" and after (as shown above) are not needed.

If the resources controlled by a CPU are limited and only 8 bytes are available for addresses, the commands from "5000h" and up can be used to access to all of the addresses owned by the central device.

5. Description of the software

5-1. Outline of control

5-1-1. Communication control

- The central device controls all the communications.
- One communication cycle consists of a communication from the central device to the local devices, and the communication from the local devices back to the central device.
- The response from the local devices may include I/O information and data.

5-1-2. Communication type

System communications, I/O communications, and data communications are the three communication types available.

1) System communications

System communications automatically confirm the connection status, device type, and I/O port settings of each local device.

By writing a system communication start command (1000h), the central device polls all of the local devices (device No. 0 to 63), one by one, and refreshes the "device information" area according to the response from the local devices.

8 bits are used for the device information about each device.

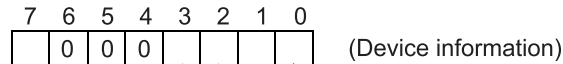

Set value	Port 0	Port 1	Port 2	Port 3	PMD2	PMD1	PMD0
000	Output	Output	Output	Output	L	L	L
001	Input	Output	Output	Output	L	L	H
010	Input	Input	Output	Output	L	H	L
011	Input	Input	Input	Output	L	H	H
Other than the above	Input	Input	Input	Input	Other than the above		

When a local device is a data device, the ports used to exchange data (status or general-purpose ports) have a different meaning for each device.

Device type
0: I/O device 1: Data device

Use of device
0: Do not use 1: Used

"When the "device information" is already known to a CPU, you can write data from a CPU. When a system communication is started during I/O communication, the central device halts the I/O communication and executes the system communication which has a higher priority. After the system communication is complete, the central device will restart the I/O communication.

Even if I/O communications are halted, the central device can still execute system communications.

2) I/O communication (cyclic communication)

In I/O communication, the central device communicates continuously to perform I/O control of the I/O devices. This communication takes place in cycles. (Communication starts with the local device that has the lowest device number and proceeds through all the devices that are present. When the

communication with the device that has the highest number is complete, the central device again starts to communicate with the local device that has the lowest device number.) If the communication target is a data device, it exchanges information such as device status.

By writing an I/O communication start command, the central device communicates only with devices whose "device information" bit is set to 1.

This communication continues until an I/O communication stop command is written.

3) Data communication

In data communication, the central device communicates with other data devices, such as the PCL G9003 device.

Normally, the central device executes cyclic I/O communications continuously. A data communication command from a CPU allows you to perform data communications by interrupting the cyclic I/O communications.

After writing data to the data transmitting FIFO, write a send data command. The central device will start the data communication on an interrupt when the current I/O communication is complete.

When the data communication is complete, the CEND bit 0 in the status register changes to "1" and an interrupt signal is output. When data is received from a data device, RDBB status register bit 10 becomes 1, so that the central device can read the data until receiving FIFO is emptied.

If data communication commands are written continuously, further data communication will be postponed until another round of I/O communications is executed once the current data communication is complete. (This ensures continuity in the cyclic I/O communications.)

After a local device has received data, it will ignore any further data received until it has read out all of the data received, and it will not send any response to the central device while reading the data. The central device will generate a no response error in this case and retry the communication.

- An example of how to write the data "01234567h" to the RMV (the feed amount register) in a PCL device (G9003).

[When using a 16-bit CPU]

- 1) First, write an RMV write command (0090h) to the transmitting FIFO (006h).
- 2) Next, write the lower 16 bits data (4567h) for the RMV register into the transmitting FIFO (006h).
- 3) Finally, write the upper 16 bits data (0123h) to be sent to the RMV register into the transmitting FIFO (006h).

Details of the data transmitting FIFO	
1st word	0090h
2nd word	4567h
3rd word	0123h

[When using an 8-bit CPU]

- 1) First, write the lower half of the RMV write command (90h) to the transmitting FIFO (006h)
- 2) Then, write the upper half (00h) of the RMV write command to the transmitting FIFO (007h)
- 3) Next, write bits 0 to 7 (67h) for the RMV register into the transmitting FIFO (006h).
- 4) Next, write bits 8 to 15 (45h) intended for the RMV register into the transmitting FIFO (007h).
- 5) Next, write bits 16 to 23 (23h) to be sent to the RMV register into the transmitting FIFO (006h).
- 6) Finally, write bits 24 to 31 (01h) for the RMV register into the transmitting FIFO (007h).

Details of the data transmitting FIFO	
1st byte	90h
2nd byte	00h
3rd byte	67h
4th byte	45h
5th byte	23h
6th byte	01h

5-1-3. Input change interrupt

When the status of an input port changes, the central device can output an interrupt request to a CPU.

A bit corresponding to any input port number whose status changed can be set to 1 in the interrupt setting register. And, if the input port data changed while receiving I/O communication data, the central device will output an interrupt request to a CPU, and it will change the bit in the input change interrupt flag register which corresponds to the input port number to 1.

Then, the CPU checks the "input change interrupt" status (IOPC = 1) when an interrupt occurs, and reads the input change interrupt flag to identify which input port changed.

By writing back the flag data just read, the interrupt can be reset.

- In the case of an I/O device

If the input port data changed while receiving I/O data, an input change interrupt will occur.

- In the case of device data

If bit 0 on input port 0 changes from 0 to 1, an input change interrupt will occur. For ports other than input port 0, if the input port data changes an input change interrupt will occur the same way as it does for I/O data.

The PCL device handles the status register (16 bits) as input ports 0 and 1, and the general-purpose I/O terminal status register as input port 2 data using I/O communication.

The status register consists of bits to stop operation, to indicate an error has happened, and to indicate an event has occurred.

Using the input change interrupt function, the central device can output an interrupt request by changing the status of the PCL device.

5-1-4. Break function

Local devices have BRK terminals. By applying a HIGH to the terminal for a certain length of time (to create a break signal), the local device will enter the break-waiting status.

Also, the central device periodically sends a "break frame sending request" to the local devices (every 16384 cycles in I/O communication, or approximately every 250 msec. at 20 Mbps), offering another way to make a break.

The local devices in break-waiting status send break frames when they receive a "break frame send request." (More than one device may send a break at once.)

The central device recognizes the break frame and outputs an interrupt request to a CPU. It also sets the "BRK" bit (bit 1) in the status register to "1."

This function is used to restore the devices that were excluded from the system, such as by device extension or due to an error.

The CPU detects an interrupt caused by a break and can then issue a system communication command. This allows it to refresh all the devices in polling operation, or to refresh the "device information" for devices that are currently stopped.

5-1-5. Control of communication errors

1) I/O communication errors

When an I/O communication error occurs, the central device does not retry the communication. However, if it fails to communicate three times in a row (three consecutive cycles), the central device will output an interrupt request to the CPU. It will also set the I/O communication error flag bit that corresponds to the I/O device number, to 1.

The CPU checks the "existence of an I/O communication error interrupt" (EIOE = 1) in the status register when an interrupt occurs and then reads the I/O communication error flags to see which I/O device has an error.

By writing back the flag data just read, the interrupt is reset.

If needed, the device with an error can be excluded from further cyclic communication by software processing in the CPU.

2) Data communication, system communication errors

When data communications or system communications from the central device fail, it automatically retries the communication three times. If it fails all three times, the central device outputs an interrupt request to the CPU. It also sets the status register "data communication, system communication error occurrence" bit (EDTE) to 1, and stores the device number which has an error (EDN0 to 5) in the interrupt status register.

The CPU checks the "data communication, system communication error interrupt" status when an interrupt occurs and then reads the interrupt status bits (EDN0 to 5) to determine which device has an error and "whether the local device received data or not" (LNRV).

The interrupt signal is reset when the interrupt status is read.

3) Other error processing

(1) When a local device detects an error in the receiving frame (such as a CRC error), it does not respond.

(2) When any of the following errors occurs in a local device, it sends notice of the error to the central device in a response frame.

- In I/O communication, a local device receives a frame that is different from the I/O setting (PMD terminal setting in case of an I/O device).
- An I/O device receives a data communication frame.
- A data device receives a frame larger than the receiving buffer capacity.

(3) If the communication line does not change after 20 μ sec or longer (when communicating at 20 Mbps) after the central device has finished sending data, it concludes that the local device could not receive the data. In data communications and system communications, the central device attempts sending the data three times. During this time, it also attempts to reestablish communications by inserting one cycle of I/O communications. If the result is still not good after the three attempts, the central device outputs an interrupt request to the CPU. If the communication line does not change during the three attempts, the central device concludes that the local device has not received the data and it will set LNRV (bit 7) in the interrupt status register to 1.

(4) When a frame received by the central device is faulty (such as a CRC error), the central device sends a resend request to the local device (a request to send the same data again). It automatically sends the resend request up to three times.

During this time, the central device also inserts one cycle of I/O communications for a retry.

If the result is still no good after three resend requests, the central device outputs an interrupt request to the CPU.

When sending this resend request, since the local device already has the data, LNRV (bit 7) in the interrupt status register will be set to 0.

5-2. Operating procedure

5-2-1. Reset

After turning ON the power, make sure to reset at least once before starting any operation.

- 1) To perform a reset, place a LOW on the RST terminal for at least 10 reference clock cycles.
- 2) Wait until the status bit 13 (RBSY) becomes 0.

5-2-2. I/O communication procedures

- 1) Write a command 1000h (start system communications to all the devices), and allow the "device information" area to be set automatically. If the "device information" is already known, you may write data/information to the devices from the CPU.
- 2) Place an initial value in the "port data" area. (Steps 1) and 2) can be performed in either order.)
- 3) Write a command 3000h to start I/O communications.

After that, write output information to the "port data" area when needed, and read input information from the "port data" area.

5-2-3. Data communication procedure

- 1) Write data to be sent (multiple words) to the "data transmitting FIFO."
- 2) Write a send data command (4000h to 403Fh) to send the data.
- 3) Wait until the status bit 0 (CEND) becomes 1.
- 4) If data has been received, the status bit 10 (RDBB) will become 1.
Until the status bit 10 (RDBB) returns to 0, the central device will read the response data from the "data receiving FIFO."

Note 1: While I/O communication is stopped, data communication is disabled.

Note 2: Writing a send data command clears the "data receiving FIFO".

5-2-4. Exclude a device with an error

- 1) The central device reads the interrupt status bits EDN0 to 5 to identify the device which has an error.
- 2) Set the "device-in-use" bit in the "device information" area, which corresponds to the device with an error, to 0.

5-2-5. Restoring excluded devices to cyclic communications

Set the corresponding "device-in-use" bit in the "device information" area to 1.

Or,

- 1) Send a rising edge ON signal to the excluded local device's BRK terminal.
- 2) When the central device receives the break frame, it will output an interrupt request to the CPU.
- 3) Write a command 1100h, check all of the excluded devices, and refresh the "device information" area.

5-3. Status after reset

"Command" --- 0000h
"Status" --- 0001h
"Interrupt status" --- 0000h
"I/O buffer" --- 0000h
"Data transmitting FIFO" --- Undetermined.
"Data receiving FIFO" --- Undetermined.
"Device information" --- All 00h
"IO communication error flag" --- All 00h
"Input change interrupt setting" --- All 00h
"Input change interrupt flag" --- All 00h
"Port data" --- All 00h

6. How to calculate the communication cycle time

The calculations of the communication cycle time can be classified as follows:

K: Communication speed figure

Communication speed (Mbps)	K
20	1
10	2
5	4
2.5	8

N: Number of local devices connected

B: Number of bytes of data to send (when sending 2 bytes of data: B = 2)

6-1. Time required for one cycle

Basic item	Required time (μ s)
Communication time required per local device (CT)	$7.7 \times K$

$$\text{Cycle time} = (CT + 7.4) \times N \text{ (}\mu\text{s)}$$

Ex.: Calculating the cycle time with a communication speed of 20 Mbps and 30 local devices.

$$(7.7 \times 1 + 7.4) \times 30 = 453 \mu\text{s}$$

6-2. Time required for one complete data communication

There are two types of data communications as follows:

- 1) When there is data in the response from a local device (the data length is variable).
- 2) When there is no data in the response from a local device.

Basic item	Required time (μ s)
Data sending time (ST)	$(B \times 0.6 + 3.25) \times K$
Response time with data (JT)	$(B \times 0.6 + 5.65) \times K$
Response time without data (JT)	$5.05 \times K$

$$\text{One complete data communication cycle} = ST + JT + 7.4 \text{ (}\mu\text{s)}$$

6-3. Total cycle time (including data communication)

The total time can be obtained by adding the data communication times to the ordinary communication cycle time.

Ex. 1: Communication speed = 20 Mbps, 34 local devices are connected, and on 4 occasions the data communication consisted of 2 bytes for sending and 6 bytes for receiving.

$$\begin{aligned} \text{Cycle time} &= \text{Cyclic time} + (\text{Data communication time}) \times \text{Number of times of data communication} \\ &= (7.7 \times 1 + 7.4) \times 34 + \{(2 \times 0.6 + 3.25) \times 1 + (6 \times 0.6 + 5.65) \times 1 + 7.4\} \times 4 \\ &= 513.4 + 21.1 \times 4 \\ &= 597.8 \mu\text{s} \end{aligned}$$

Note: The formula above contains some margin for error. In actual operation, a shorter total time can be obtained.

However, if a communication error occurs, the total time will be longer than the calculated time.

7. Electrical Characteristics

7-1. Absolute maximum ratings

Item	Symbol	Rating	Unit
Power supply voltage	V_{DD}	$V_{SS}-0.3$ to $+4.0$	V
Input voltage	V_{IN}	$V_{SS}-0.3$ to $V_{DD}+0.5$	V
Input voltage (5V-I/F)	V_{IN}	$V_{SS}-0.3$ to $+7.0$	V
Output current / Terminal	I_{OUT}	± 30	mA
Storage temperature	T_{STO}	-65 to $+150$	$^{\circ}\text{C}$

7-2. Recommended operating conditions

Item	Symbol	Rating	Unit
Power supply voltage	V_{DD}	$+0.3 \pm 10\%$	V
Input voltage	V_{IN}	V_{SS} to V_{DD}	V
Input voltage (5V-I/F)	V_{IN}	V_{SS} to $+5.5$	V
Storage temperature	T_a	-40 to $+85$	$^{\circ}\text{C}$

7-3. DC characteristics

Item	Symbol	Condition	Min.	TYP	Max.	Unit
Current consumption	I_{dd}	CLK = 80 MHz			45	mA
Output leakage current	I_{OZ}		-1		1	μA
Input capacitance					10	pF
LOW input current	I_{IL}		-1			μA
HIGH input current	I_{HL}				1	μA
LOW input voltage	V_{IL}				0.8	V
HIGH input voltage	V_{IH}		2.0			V
LOW output voltage	V_{OL}	$I_{OL} = 6 \text{ mA}$			0.4	V
HIGH output voltage	V_{OH}	$I_{OH} = -6 \text{ mA}$	$V_{DD}-0.4$			V
LOW output current	I_{OL}	$V_{OL} = 0.4 \text{ V}$			6	mA
HIGH output current	I_{OH}	$V_{OH} = V_{DD}-0.4 \text{ V}$	-6			mA
Internal pull up resistance	R_{UP}		20		120	K-ohm

7-4. AC characteristics

7-4-1. System clock

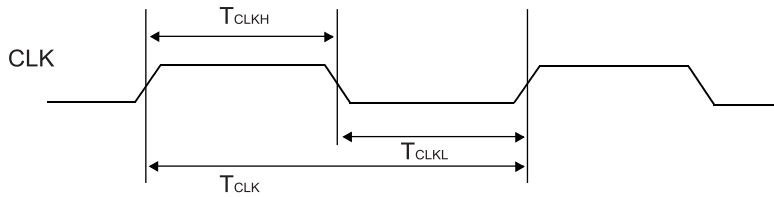

1) When setting CKSL = L

Item	Symbol	Min.	Standard	Max.	Unit
Frequency	f_{CLK}	-	40	40	MHz
Cycle	T_{CLK}	-	25	25	ns
HIGH duration	T_{CLKH}	10	12.5	15	ns
LOW duration	T_{CLKL}	10	12.5	15	ns

Note: In order to secure good communication quality, use a clock offering the nearest figures to the standards above.

For details, see the "CLK" section of the "terminal function" in this manual.

2) When setting CKSL = H

Item	Symbol	Min.	Standard	Max.	Unit
Frequency	f_{CLK}	-	-	80	MHz
Cycle	T_{CLK}	-	-	12.5	ns
HIGH duration	T_{CLKH}	-	-	-	ns
LOW duration	T_{CLKL}	-	-	-	ns

7-4-2. Reset timing

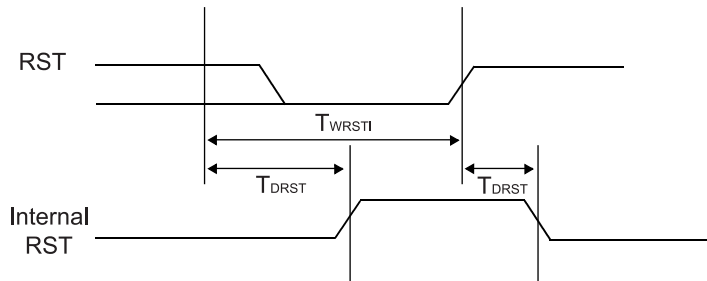

Item	Symbol	Min.	Standard	Max.	Unit
Reset length	T_{WRSTI}	10	-	-	Clock cycles
Delay time	T_{DRST}	-	10	-	Clock cycles

Note 1: The reset signal must last at least 10 cycles of the system clock.

While resetting, Make sure the clock signal is continuously available to the device.

If the clock is stopped while resetting, the device cannot be reset normally.

Note 2: After the internal RST goes LOW, the central device automatically resets the internal memory area to all zeros (address: 078h to 1ffh). After the reset is complete, the central device is once again ready.

During the reset, the status RBSY (bit 13) remains 1. Therefore, make sure that this bit has returned to 0 before accessing the central device at the end of a reset.

The following are the minimum times needed to reset the internal memory area.

CKSL = L --- $270 T_{CLK}$ (6.75 μ sec at 40 MHz)

CKSL = H --- $540 T_{CLK}$ (6.75 μ sec at 80 MHz)

7-4-3. I/F mode 4 (IF1=H, IF0=H)

- Read cycle

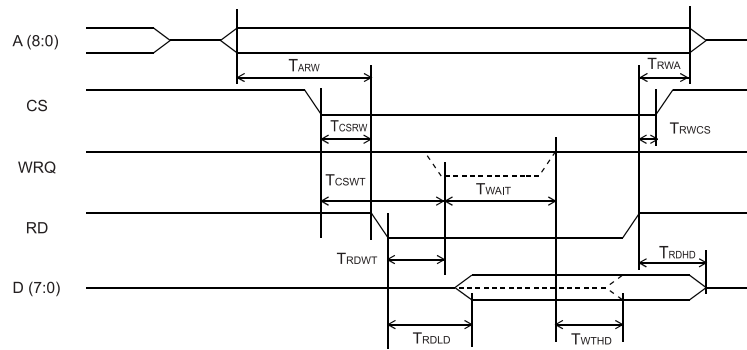

- Write cycle

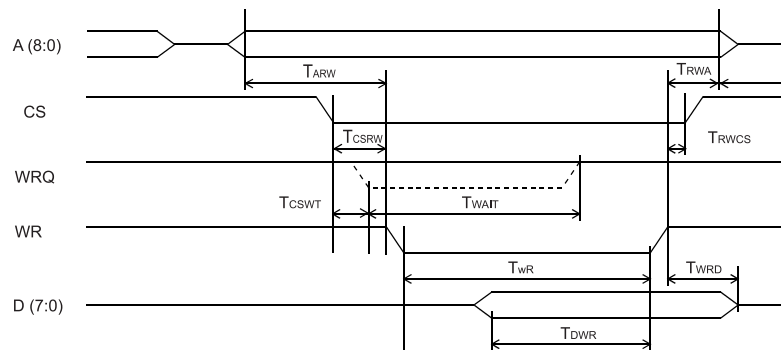

Item	Symbol	Condition	Min.	Max.	Unit
Address setup time for RD, WR ↓	T_{ARW}		18		ns
Address hold time for RD, WR ↑	T_{RWA}		0		ns
\overline{CS} setup time for RD, WR ↓	T_{CSRW}		8		ns
\overline{CS} hold time for RD, WR ↑	T_{RWCS}		0		ns
WRQ=ON delay time for CS ↓	T_{CSWT}	$C_L = 40\text{pF}$		11	ns
WRQ=ON delay time for RD ↓	T_{RDWT}	$C_L = 40\text{pF}$ Note 1		17	ns
WRQ signal LOW time	T_{WAIT}	Note 2		$12T_{CLK}$	ns
Data output delay time for RD ↓	T_{RDLD}	$C_L = 40\text{pF}$ Note 3, 4		$2T_{CLK}+24$	ns
		$C_L = 40\text{pF}$ Note 5		28	ns
Data output delay time for WRQ ↑	T_{WTHD}	$C_L = 40\text{pF}$ Note 4		0	ns
		$C_L = 40\text{pF}$ Note 5		10	ns
Data float delay time for RD ↑	T_{RDHD}	$C_L = 40\text{pF}$		28	ns
\overline{WR} signal width TWR	T_{WR}	Note 6	14		ns
Data setup time for WR ↑	T_{DWR}		22		ns
Data hold time for WR ↑	T_{WRD}		0		ns

Note 1: Only when reading memory area (address 078h to 1FFh), WRQ = LOW will be output by RD = LOW.

Note 2: When CKSL = LOW or CKSL = HIGH, the WRQ signal LOW level will be held for $24 \times T_{CLK}$.

Note 3: When CKSL = LOW or CKSL = HIGH, the data output delay time will be $4T_{CLK} + 24$.

Note 4: When reading memory address (addresses 078h to 1FFh).

Note 5: When reading non memory addresses (addresses 078h to 1FFh).

Note 6: The time that the WRQ signal is output will be the interval after WRQ goes HIGH until WR goes HIGH.

7-4-4. I/F mode 3 (IF1=H, IF0=L)

- Read cycle

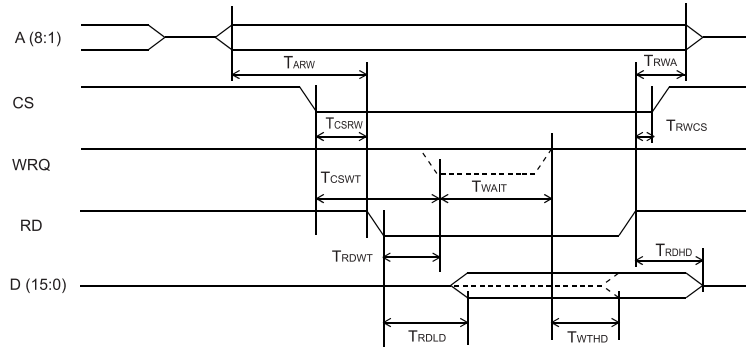

- Write cycle

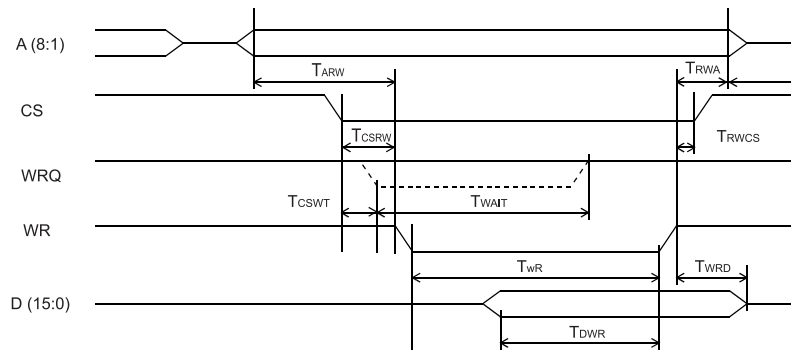

Item	Symbol	Condition	Min.	Max.	Unit
Address setup time for RD, WR ↓	T_{ARW}		18		ns
Address hold time for RD, WR ↑	T_{RWA}		0		ns
\overline{CS} setup time for RD, WR ↓	T_{CSRW}		8		ns
\overline{CS} hold time for RD, WR ↑	T_{RWCS}		0		ns
WRQ=ON delay time for CS ↓	T_{CSWT}	$C_L = 40\text{pF}$		11	ns
WRQ=ON delay time for RD ↓	T_{RDWT}	$C_L = 40\text{pF}$ Note 1		17	ns
WRQ signal LOW time	T_{WAIT}	Note 2		$12T_{CLK}$	ns
Data output delay time for RD ↓	T_{RDLD}	$C_L = 40\text{pF}$ Note 3, 4		$2T_{CLK}+24$	ns
		$C_L = 40\text{pF}$ Note 5		28	ns
Data output delay time for WRQ ↑	T_{WTHD}	$C_L = 40\text{pF}$ Note 4		0	ns
		$C_L = 40\text{pF}$ Note 5		10	ns
Data float delay time for RD ↑	T_{RDHD}	$C_L = 40\text{pF}$		28	ns
\overline{WR} signal width TWR	T_{WR}	Note 6	14		ns
Data setup time for WR ↑	T_{DWR}		22		ns
Data hold time for WR ↑	T_{WRD}		0		ns

Note 1: Only when reading memory area (address 078h to 1FFh), WRQ = LOW will be output by RD = LOW.

Note 2: When CKSL = LOW or CKSL = HIGH, the WRQ signal LOW level will be held for $24 \times T_{CLK}$.

Note 3: When CKSL = LOW or CKSL = HIGH, the data output delay time will be $4T_{CLK} + 24$.

Note 4: When reading memory address (addresses 078h to 1FFh).

Note 5: When reading non memory addresses (addresses 078h to 1FFh).

Note 6: The time that the WRQ signal is output will be the interval after WRQ goes HIGH until WR goes HIGH.

7-4-5. I/F mode 2 (IF1=L, IF0=H)

- Read cycle

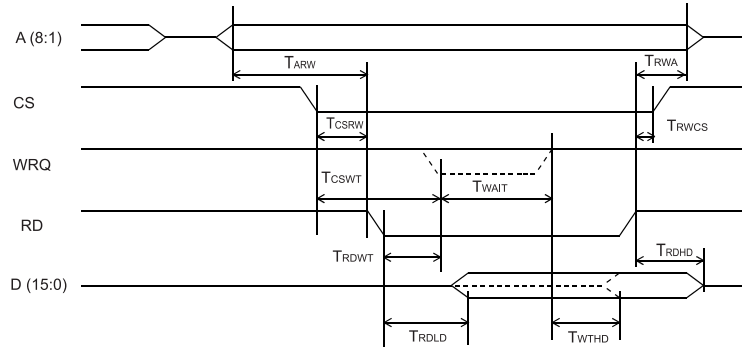

- Write cycle

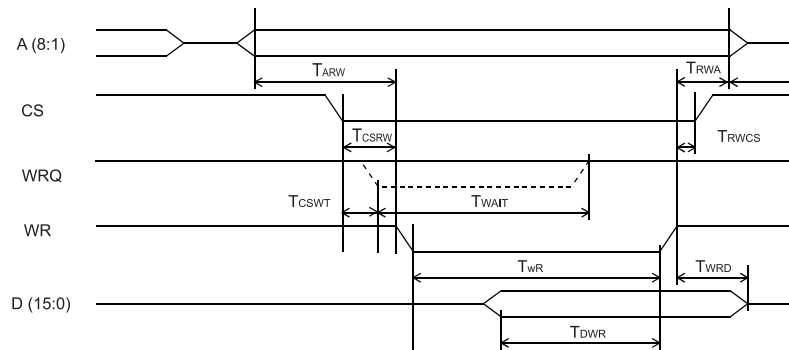

Item	Symbol	Condition	Min.	Max.	Unit
Address setup time for RD, WR ↓	T_{ARW}		18		ns
Address hold time for RD, WR ↑	T_{RWA}		0		ns
\overline{CS} setup time for RD, WR ↓	T_{CSRW}		8		ns
\overline{CS} hold time for RD, WR ↑	T_{RWCS}		0		ns
WRQ=ON delay time for CS ↓	T_{CSWT}	$C_L = 40\text{pF}$		11	ns
WRQ=ON delay time for RD ↓	T_{RDWT}	$C_L = 40\text{pF}$ Note 1		17	ns
WRQ signal LOW time	T_{WAIT}	Note 2		$12T_{CLK}$	ns
Data output delay time for RD ↓	T_{RDLD}	$C_L = 40\text{pF}$ Note 3, 4		$2T_{CLK}+24$	ns
		$C_L = 40\text{pF}$ Note 5		28	ns
Data output delay time for WRQ ↑	T_{WTHD}	$C_L = 40\text{pF}$ Note 4		0	ns
		$C_L = 40\text{pF}$ Note 5		10	ns
Data float delay time for RD ↑	T_{RDHD}	$C_L = 40\text{pF}$		28	ns
\overline{WR} signal width T_{WR}	T_{WR}	Note 6	14		ns
Data setup time for WR ↑	T_{DWR}		22		ns
Data hold time for WR ↑	T_{WRD}		0		ns

Note 1: Only when reading memory area (address 078h to 1FFh), WRQ = LOW will be output by RD = LOW.

Note 2: When CKSL = LOW or CKSL = HIGH, the WRQ signal LOW level will be held for $24 \times T_{CLK}$.

Note 3: When CKSL = LOW or CKSL = HIGH, the data output delay time will be $4T_{CLK} + 24$.

Note 4: When reading memory address (addresses 078h to 1FFh).

Note 5: When reading non memory addresses (addresses 078h to 1FFh).

Note 6: The time that the WRQ signal is output will be the interval after WRQ goes HIGH until WR goes HIGH.

7-4-6. I/F mode 1 (IF1=L, IF0=L)

- Read cycle

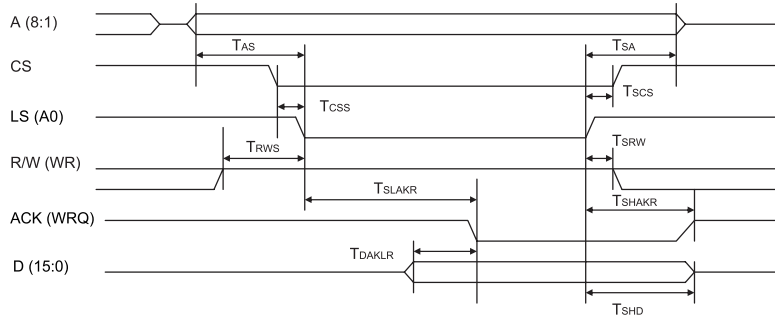

- Write cycle

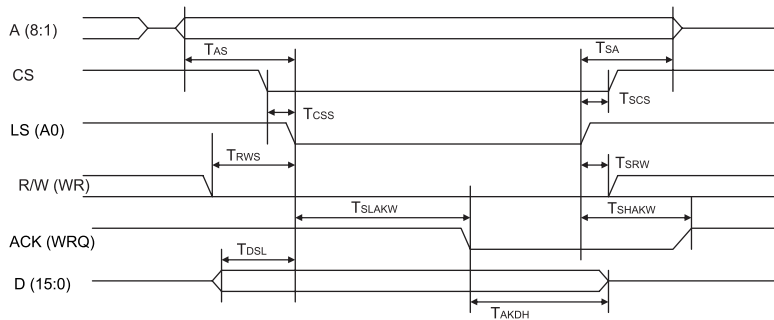

Item	Symbol	Condition	Min.	Max.	Unit
Address setup time for LS ↓	T_{AS}		17		ns
Address hold time for LS ↑	T_{sa}		0		ns
CS setup time for LS ↓	T_{CSS}		10		ns
CS hold time for LS ↑	T_{scs}		0		ns
R/W setup time for LS ↓	T_{RWS}		2		ns
R/W hold time for LS ↑	T_{SRW}		14		ns
ACK=ON delay time for LS ↓	T_{SLAKR}	$C_L = 40\text{pF}$ Note 1	$2T_{CLK}$	$14T_{CLK}+15$	ns
	T_{SLAKW}	$C_L = 40\text{pF}$ Note 2	$2T_{CLK}$	$10T_{CLK}+15$	ns
ACK=ON delay time for LS ↑	T_{SHAKR}	$C_L = 40\text{pF}$		7	ns
	T_{SHAKW}	$C_L = 40\text{pF}$		7	ns
Data float delay time for ACK ↓	T_{DAKLR}	$C_L = 40\text{pF}$ Note 3	$2T_{CLK}$		ns
Data float delay time for LS ↑	T_{SHD}	$C_L = 40\text{pF}$		14	ns
Data setup time for LS ↑	T_{DSL}		22		ns
Data hold time for ACK ↓	T_{AKDH}		0		ns

Note 1: When CKSL = LOW or CKSL = HIGH, the ACK signal LOW level will be held for MIN = $4 \times T_{CLK}$, MAX = $28T_{CLK} + 15$.

Note 2: When CKSL = LOW or CKSL = HIGH, the ACK signal LOW level will be held for MIN = $4 \times T_{CLK}$, MAX = $20T_{CLK} + 15$.

Note 3: When CKSL = LOW or CKSL = HIGH, the data float delay time will be $4T_{CLK}$.

8. External dimensions

Plastic QFP13-64pin Unit: mm

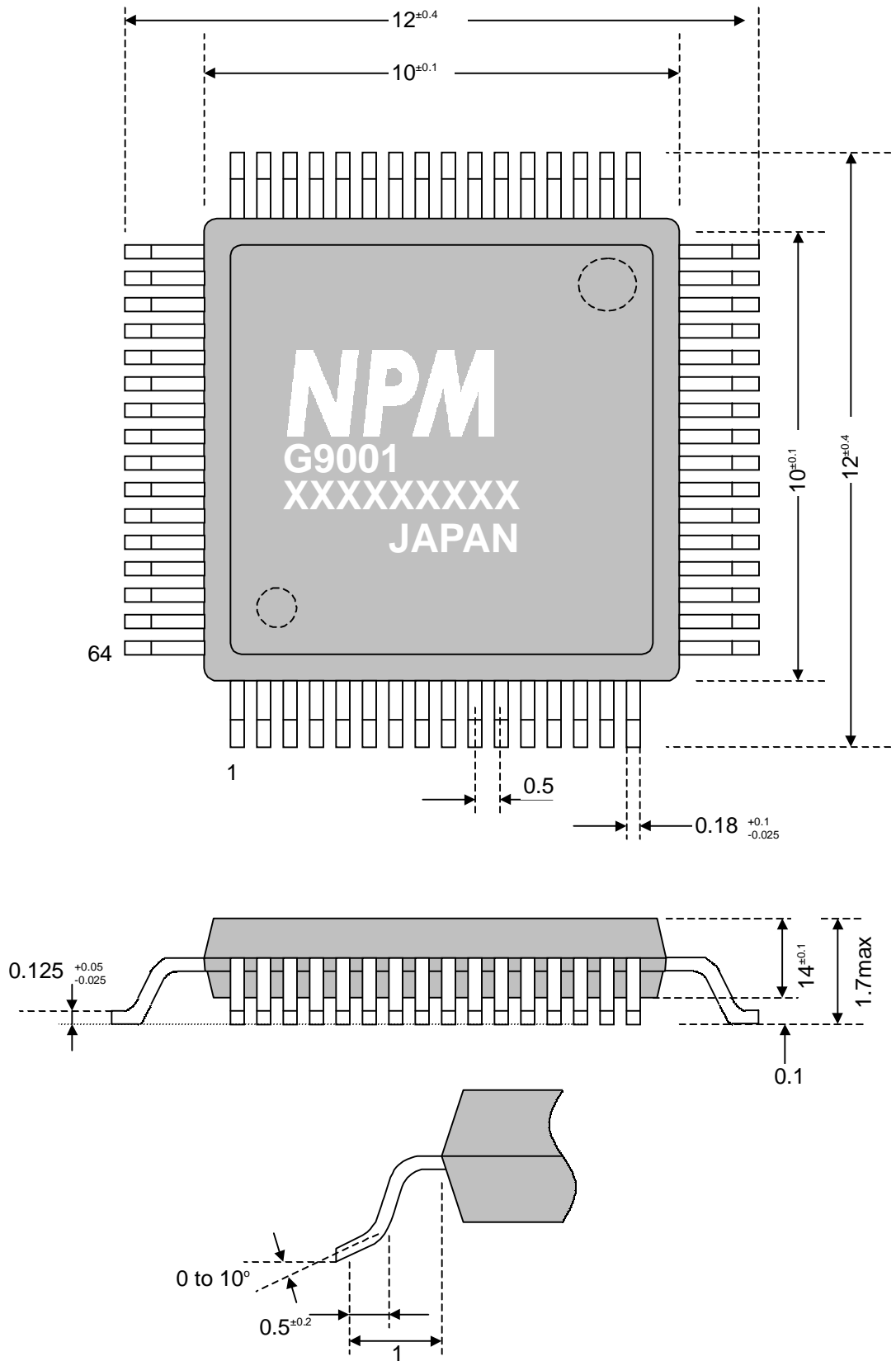

II. I/O device (G9002)

User's Manual

1. Outline

This LSI is an I/O device for the Motionnet system.

The central device can control input and output signals for four ports (each of which can be specified as an input or output port using terminal settings). (One port = 8 bits)

2. Features

- Four I/O terminal ports can be controlled. Each port has 8 bits.
- Input or output operation can be selected for each port. Specify the I/O selection using the LSI terminals.
- The signal logic can be specified for each I/O port. Specify the logic using the LSI terminals.
- A single 3.3 V power source is all that is needed.
Connections can be made to 5 V devices on the main terminals.

3. Basic specifications

3-1. I/O device specifications (G9002)

Item	Description
Number of input/output ports	4 input/output ports (1 port = 8 bits) Input or output operation can be selected using the terminals. The I/O signal logic can be set for each port using the terminals.
Transfer system	Cyclic transfer
Package	80-pin QFP (Mold size: 12 x 12 x 1.4 mm)
Power source	3.3 V \pm 10%
Storage temperature range	-40 to +125°C
Operation temperature range	-40 to + 85°C

4. Hardware Description

4-1. List of terminals (QFP-80)

No.	Signal name	I/O	Logic	Description	5 V interface
1	MRER	O	Negative	Goes LOW for a specified time when an abnormal communication is received	
2	MSEL	O	Negative	Goes LOW for a specified time when this I/O device is receiving data.	
3	TOUT	O	Negative	Watchdog timer output	
4	TMD	I		Enable the watchdog timer	Available
5	TUD	I		Specify the operation when the watchdog timer signal (TOUT) is output.	Available
6	SI	I	Positive	Serial input	
7	SOEL	O	Negative	Enables serial output	
8	SOEH	O	Positive	Enables serial output	
9	SO	O	Positive	Serial output	
10	P0N	I	Negative	LOW: Sets P00 to P07 to use negative logic.	Available
11	VDD	I		Power source +3.3 V	
12	GND	I		GND	
13	P00	B	-	Bit 0 on port 0	Available
14	P01	B	-	Bit 1 on port 0	Available
15	P02	B	-	Bit 2 on port 0	Available
16	P03	B	-	Bit 3 on port 0	Available
17	P04	B	-	Bit 4 on port 0	Available
18	P05	B	-	Bit 5 on port 0	Available
19	P06	B	-	Bit 6 on port 0	Available
20	P07	B	-	Bit 7 on port 0	Available
21	VDD	I		Power source: +3.3 V	
22	GND	I		GND	
23	P1N	I	Negative	LOW: Sets P10 to P17 to use negative logic.	Available
24	P10	B	-	Bit 0 on port 1	Available
25	P11	B	-	Bit 1 on port 1	Available
26	P12	B	-	Bit 2 on port 1	Available
27	P13	B	-	Bit 3 on port 1	Available
28	P14	B	-	Bit 4 on port 1	Available
29	P15	B	-	Bit 5 on port 1	Available
30	P16	B	-	Bit 6 on port 1	Available
31	P17	B	-	Bit 7 on port 1	Available
32	GND	I		GND	
33	VDD	I		Power source: +3.3 V	
34	P20	B	-	Bit 0 on port 2	Available
35	P21	B	-	Bit 1 on port 2	Available
36	P22	B	-	Bit 2 on port 2	Available
37	P23	B	-	Bit 3 on port 2	Available
38	P24	B	-	Bit 4 on port 2	Available
39	P25	B	-	Bit 5 on port 2	Available
40	P26	B	-	Bit 6 on port 2	Available
41	P27	B	-	Bit 7 on port 2	Available
42	VDD	I		Power source: +3.3 V	
43	GND	I		GND	
44	P30	B	-	Bit 0 on port 3	Available
45	P31	B	-	Bit 1 on port 3	Available

No.	Signal name	I/O	Logic	Description	5 V interface
46	P32	B	-	Bit 2 on port 3	Available
47	P33	B	-	Bit 3 on port 3	Available
48	P34	B	-	Bit 4 on port 3	Available
49	P35	B	-	Bit 5 on port 3	Available
50	P36	B	-	Bit 6 on port 3	Available
51	P37	B	-	Bit 7 on port 3	Available
52	GND	I		GND	
53	VDD	I		Power source: +3.3 V	
54	P2N	I	Negative	LOW: Sets P20 to P27 to use negative logic.	Available
55	P3N	I	Negative	LOW: Sets P30 to P37 to use negative logic.	Available
56	SOEI	I	Positive	Enables serial output	
57	BRK	I	Positive	Requests a break frame to be sent.	Available
58	RST	I	Negative	Reset	Available
59	DNSM	I	Negative	Mode to set the device number	Available
60	DNSO	O	Negative	Serial output of next chip device number	
61	GND	I		GND from the power supply	
62	CKSL	I		Select clock rate (L: 40 MHz, H: 80 MHz)	Available
63	VDD	I		Power source: + 3.3 V	
64	GND	I		GND	
65	PMD0	I		Selects input/output port mode 0	Available
66	PMD1	I		Selects input/output port mode 1	Available
67	PMD2	I		Selects input/output port mode 2	Available
68	SPD0	I	-	Selects communication speed 0	Available
69	SPD1	I	-	Selects communication speed 1	Available
70	VDD	I		Power source: +3.3 V	
71	GND	I		GND	
72	CLK	I	-	Reference clock	
73	VDD	I		Power source: +3.3 V	
74	GND	I		GND	
75	DN5	I	Negative	Device number bit 5	Available
76	DN4	I	Negative	Device number bit 4	Available
77	DN3	I	Negative	Device number bit 3	Available
78	DN2	I	Negative	Device number bit 2	Available
79	DN1	I	Negative	Device number bit 1	Available
80	DN0	I	Negative	Device number bit 0 (common with the serial input line)	Available

4-2. Terminal assignment drawings

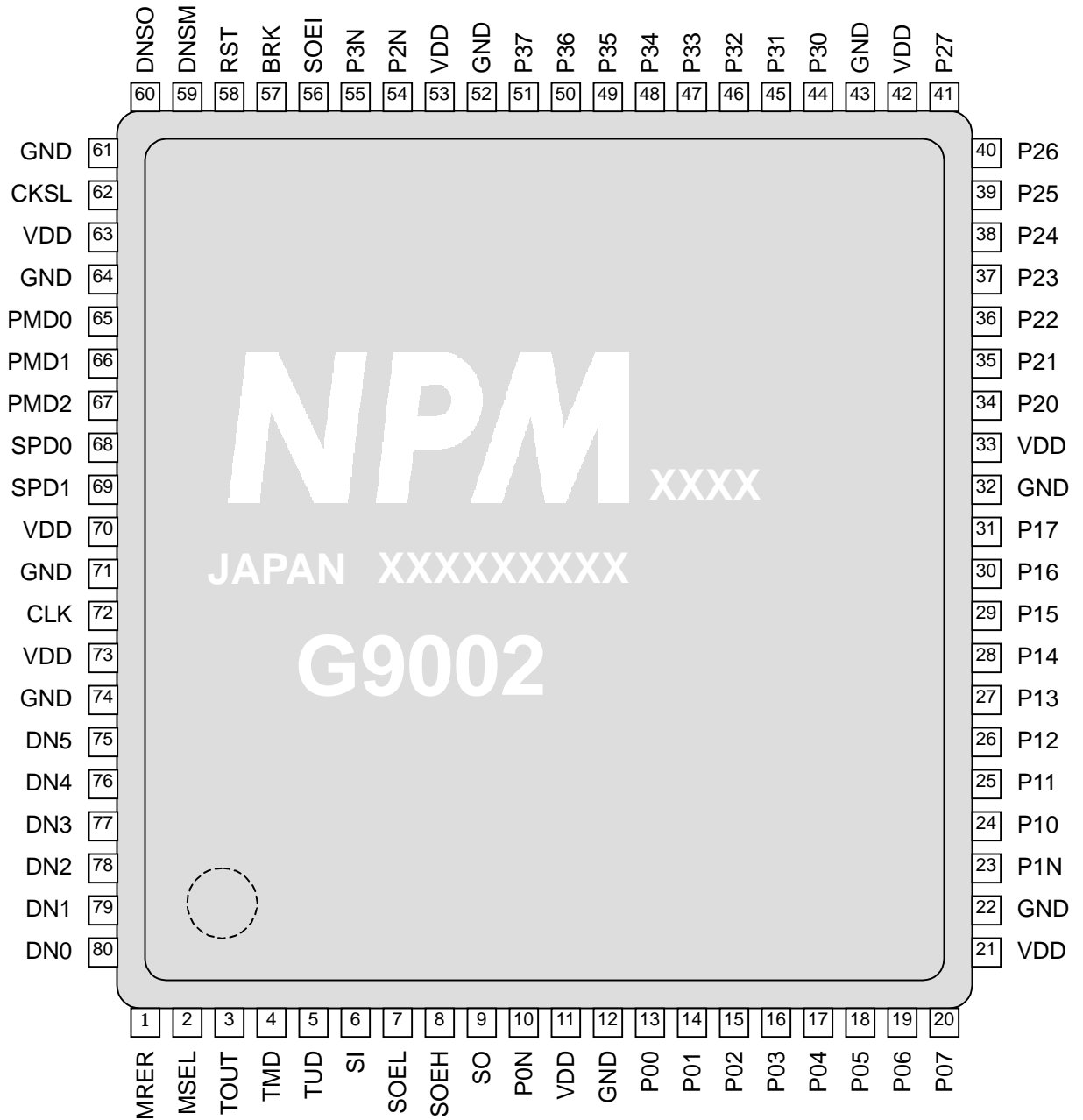

Note: Locate each pin number from the markings on the chip.

As shown in the figure above, pin number 1 is at the lower left of the NPM logo mark.

4-3. Complete block diagram

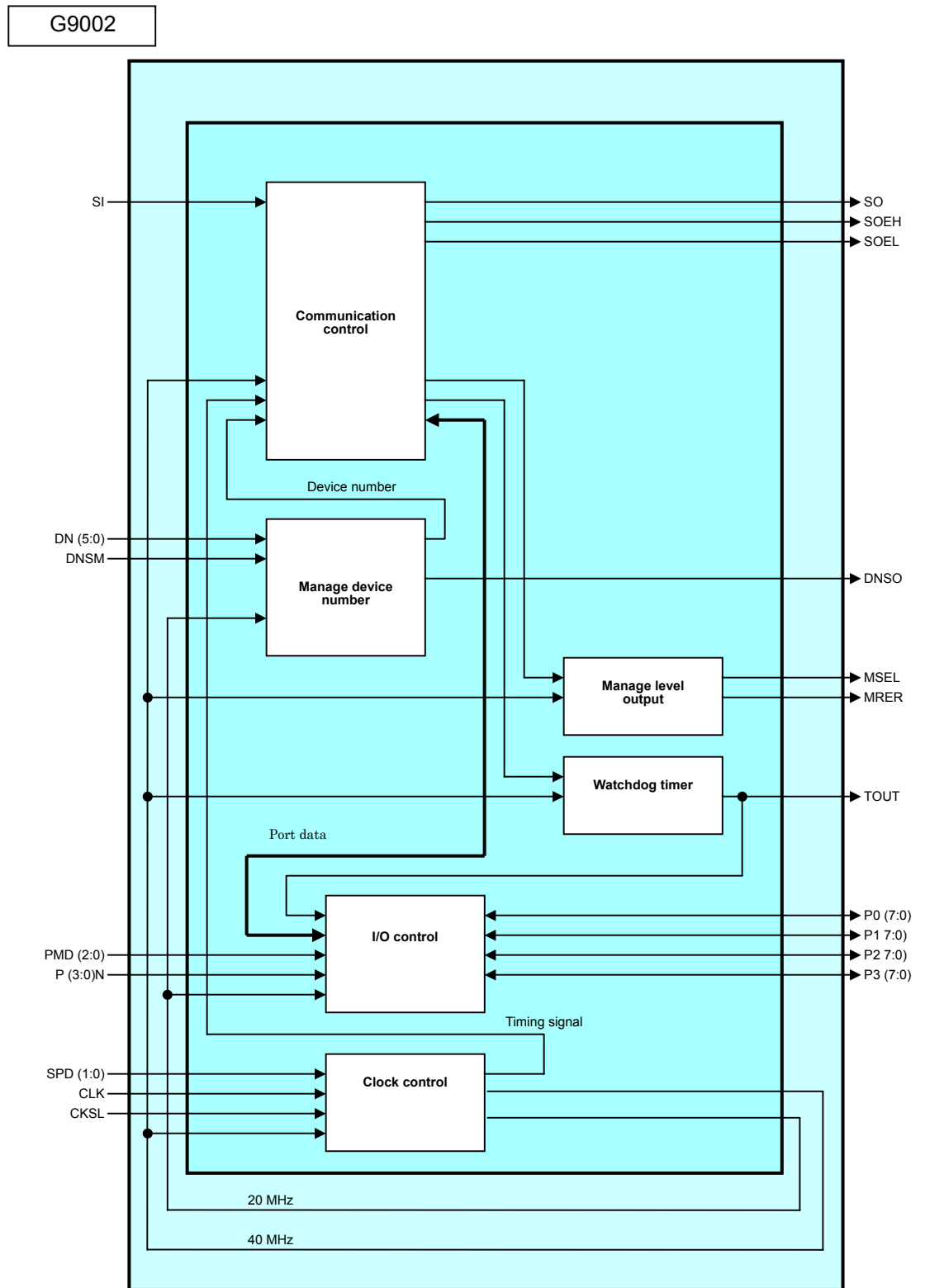

4-4. Functions of terminals

4-4-1. CLK

This is an input terminal of the reference clock. By setting of the CKSL terminal, either of the following clock rate signals can be connected.

CKSL = L: 40 MHz

CKSL = H: 80 MHz

By selecting either of these clock rates, the serial communication transfer rate does not change. This clock rate selection affects communication precision.

For a small-scale serial communication and transfer rate below 10 Mbps, use of the center device with 40 MHz does not give any restriction.

With 20 Mbps transfer speed; however, a longer communication line or a large number of connected local devices may deteriorate communication precision due to collapse of signals on the circuit. This deterioration of communication quality can be corrected inside the LSI, if the deterioration level is not much. In order to improve correction precision, evenness of the clock duty is required. In other words, if the duty is ideal (50:50), the capacity to correct collapse of the signals in the communication lines can be improved. On the contrary, if the duty is not ideal, the center device cannot cope with collapses of the communication line.

As a result, if the duty is close to ideal, the center device can be used with 40 MHz. When connecting more than one oscillators, the duty will not be ideal. In this case, select 80 MHz. The central device divides the frequency inside and creates 40 MHz frequency.

If you do not want to 80 MHz frequency, you may prepare a separate 40 MHz oscillator for this LSI.

4-4-2. RST

This is an input terminal for a reset signal.

By input L level signal, the central device is reset. As the central device synchronizes with a clock, arrange a circuit so that it does not disconnect the clock while resetting. Reset signal length longer than 10 clock cycles is required.

4-4-3. CKSL

Use to select clock rate.

L: Connect 40 MHz clock frequency to the CLK terminal.

H: Connect 80 MHz clock frequency to the CLK terminal.

Select this when the duty of the 40 MHz clock collapses too much.

4-4-4. DN0 to DN5

Input terminals for setting device address.

Since these terminals use negative logic, setting all the terminals to zero calls up device address "3Fh."

There are two methods for entering a device address. Select the input method using the DNSM terminal.

4-4-5. DNSM

Select the input method for loading the device address.

1) When the DNSM = H

Specify an address from 00h to 3Fh using the DN0 to DN5 terminals.

2) When the DNSM = L

Input a DNSO signal that is output by some other chip on the DN0 terminal on this device. When using this input method, this chip has an address equal to the other chip's address plus one.

When using this method, connect terminals DN1 to DN5 to GND.

When two sequential sets of serial data match, the data is taken to be a device address.

4-4-6. DNSO

The numeric equivalent of the address on DN0 to DN5 + 1 will be output after being converted into a serial bit stream.

Connect this output to another local device's DN0 terminal (make all the other DNSM terminals of that local device LOW), so that other devices can get the address and pass it along to the next data-sending device.

Please note that the next address after "3Fh" (DN(5:0) = "000000") is "00h."

4-4-7. SPD0, SPD1

Set the communications speed

All of the devices on the same communication line must be set to the same speed.

SPD1	SPD0	Communication speed
L	L	2.5 Mbps
L	H	5 Mbps
H	L	10 Mbps
H	H	20 Mbps

4-4-8. TUD

A watchdog timer is included on the chip to assist in administration of the communication status (see the "TMD" terminal section).

When the data transmission interval from a central device to this device exceeds the set time, the watchdog timer times out.

This terminal is used to set output conditions when the watchdog timer times out.

When TUD = HIGH --- The LSI keeps its current status.

When the TUD = LOW --- The LSI is Reset.

4-4-9. TMD

Specify the time for the watchdog timer.

The watchdog timer is used to administer the communication status.

When the interval between data packets sent from a central device is longer than the specified interval, the watchdog timer times out (the timer restarts its count at the end of each data packet received from a central device). The time out may occur because of a problem on the communication circuit, such as disconnection, or simply because the central device has stopped communicating.

The time used by the watchdog timer varies with communication speed selected.

TMD terminal	Watchdog timer setting			
	20 Mbps	10 Mbps	5 Mbps	2.5 Mbps
L	5 ms	10 ms	20 ms	40 ms
H	20 ms	40 ms	80 ms	160 ms

4-4-10. TOUT

Once the watchdog timer has timed out, this terminal goes LOW.

4-4-11. SO

Serial output signal for communication. (Positive logic, tri-state output)

4-4-12. SOEH, SOEL

Output enable signal for communication.

The difference between the SOEH and SOEL is that the logic is inverted.

When sending, SOEH = HIGH and SOEL = LOW.

4-4-13. SOEI

When using more than one I/O device, connect the SOEH signal of the other I/O device to this terminal.

By being wire OR'ed with the output enable signal from this I/O device, the device outputs an enable signal to SOEH or SOEL.

4-4-14. SI

Serial input signal for communication. (Positive logic)

4-4-15. MRER

Monitor output used to check communication quality.

When the I/O device receives an error frame such as a CRC error, this terminal goes LOW for exactly 128 CLK cycles (3.2 μ s).

By timing this interval using a counter, you can check the quality of the communication.

4-4-16. MSEL

Communication status monitor output.

When the I/O device receives a frame intended for this device and everything is normal (when communication MFER is OFF), this terminal goes LOW for exactly 128 CLK cycles (3.2 μ s). This can be used to check the cyclic communication time.

4-4-17. BRK

By providing HIGH pulses that are longer than the specified interval, the I/O device will be made to wait for a break frame.

When the I/O device receives a break frame send request from a central device, it immediately sends a break frame.

A pulse at least 3200 μ sec long is needed, in order to be seen as the BRK input pulse (positive logic).

4-4-18. PMD0 to PMD2

Terminals used to determine the port direction of the four I/O ports.
These terminals can set the ports as follows:

PMD2	PMD1	PMD0	P0(7:0)	P1(7:0)	P2(7:0)	P3(7:0)
L	L	L	Output	Output	Output	Output
L	L	H	Input	Output	Output	Output
L	H	L	Input	Input	Output	Output
L	H	H	Input	Input	Input	Output
H	L	L	Input	Input	Input	Input

When PMD0 to 2 are set other than as shown above, all the ports will be input ports. However, do not use any settings not shown.

4-4-19. P0N, P1N, P2N, P3N

Specify the input/output logic for each port. (P0N corresponds to port 0, P1N corresponds to port 1, P2N corresponds to port 2, and P3n corresponds to port 3.)

If a port is set HIGH by the corresponding PxN terminal, then when this port is HIGH the central device will see a 1.

If a port is set LOW by the corresponding PxN terminal, then when this port is LOW the central device will see a 1.

4-4-20. P00 to 07, P10 to 17, P20 to 27, P30 to 37

Input/output port terminals.

When used in output mode, these terminal outputs are open drains. Therefore, they should be pulled up externally (a few k-ohms is all that is needed).

1) 5 V input and output are possible in the following conditions:

- As an input: Connect a 5 V signal.
- As an output: the pins can be pulled up to 5 V.

2) Be careful not to provide too much voltage by reflection or linking.

3) We recommend the use of diodes at each terminal to prevent the possibility of too much voltage.

4-5. Status after reset

P00 to P07: When P0N = LOW, HIGH, when P0N = HIGH, LOW (when output is selected)

P10 to P17: When P1N = LOW, HIGH, when P1N = HIGH H, LOW (when output is selected)

P20 to P27: When P2N = LOW, HIGH, when P2N = HIGH, LOW (when output is selected)

P30 to P37: When P3N = LOW, HIGH, when P3N = HIGH, LOW (when output is selected)

Note: A HIGH output H means that the terminal is externally pulled up to the voltage provided by the power supply.

Output circuits for the I/O port terminals are open drains, in order to handle a 5 V output.

Therefore, an external pull up resistor is essential for correct operation. A resistor with a few K-ohms is all that is needed to pull up the terminal.

5. Electrical Characteristics

5-1. Absolute maximum ratings

(V_{SS} = 0V)

Item	Symbol	Rating	Unit
Power supply voltage	V _{DD}	-0.3 to +5.0	V
Input voltage	V _{IN}	-0.3 to V _{DD} +0.3	V
Input voltage (5V-I/F)	V _{IN}	-0.3 to +7.0	V
Output resisting voltage (open drain)	V _{ODP}	-0.3 to +7.0	V
Input current	I _{IN}	±10	mA
Storage temperature	T _{STO}	-40 to +125	°C

5-2. Recommended operating conditions

(V_{SS} = 0V)

Item	Symbol	Rating	Unit
Power supply voltage	V _{DD}	+0.3±10%	V
Input voltage	V _{IN}	V _{DD}	V
Input voltage (5V-I/F)	V _{IN}	Up to 5.5	V
Storage temperature	T _a	-40 to +85	V

5-3. DC characteristics

(V_{SS} = 0V)

Item	Symbol	Condition	Min.	Max.	Unit
Current consumption	I _{dd}	CLK = 80 MHz		36	mA
Output leakage current	I _{OZ}		-10	10	μA
Input capacitance				5.6	pF
LOW input current	I _{IL}		-10	10	μA
HIGH input current	I _{HL}		-10	10	μA
LOW input current	V _{IL}	Terminals except CLK.		0.8	V
		CLK terminal		V _{DD} × 0.2	V
HIGH input current	V _{IH}	Terminals except CLK.	2.0		V
		CLK terminal	V _{DD} × 0.8		V
LOW output voltage	V _{OL}	I _{OL} = 4 mA		0.4	V
		Bi-directional I/F I _{OL} -8mA		0.4	V
		I _{OL} = 1 μA		V _{SS} +0.05	V
HIGH output voltage	V _{OH}	I _{OH} = -4 mA	2.4		V
		I _{OH} = -1 μA	V _{dd} -0.05		V
LOW output current	I _{OL}	V _{OL} = 0.4 V		4	mA
		Bi-directional I/F V _{OL} = 0.4V		8	mA
HIGH output current	I _{OH}	V _{OH} = 2.4 V	-4		mA

5-4. AC characteristics

5-4-1. System clock

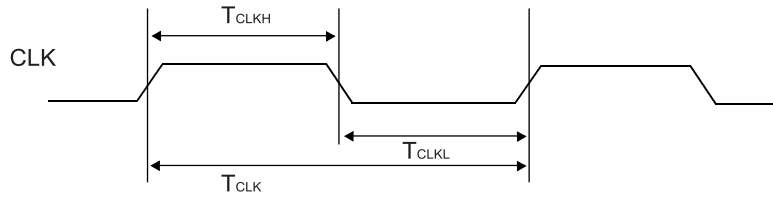

1) When setting CKSL = L

Item	Symbol	Min.	Max.	Unit
Frequency	f_{CLK}	-	40	MHz
Cycle	T_{CLK}	25	-	ns
HIGH duration	T_{CLKH}	10	15	ns
LOW duration	T_{CLKL}	10	15	ns

Note: In order to secure good communication quality, use a clock offering the nearest figures to the standards above.

For details, see the "CLK" section of the "Terminal Function" in this manual.

2) When setting CKSL = H

Item	Symbol	Min.	Max.	Unit
Frequency	f_{CLK}	-	80	MHz
Cycle	T_{CLK}	12.5	-	ns
HIGH duration	T_{CLKH}	-	-	ns
LOW duration	T_{CLKL}	-	-	ns

5-4-2. Reset timing

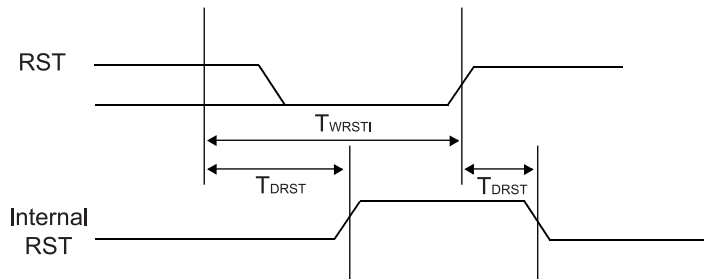

Item	Symbol	Min.	Max.	Unit
Reset length	T_{WRSTI}	10	-	Clock cycles
Delay time	T_{DRST}	-	10	Clock cycles

Note 1: After the internal RST goes LOW, the I/O device will be ready.

Note 2: The reset signal must last at least 10 cycles of the system clock.

While resetting, make sure the clock signal is continuously available to the device.
If the clock is stopped while resetting, the device cannot be reset normally.

5-4-3. Fixed output data timing

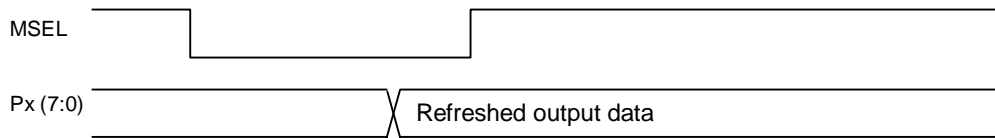

The I/O device refreshes the received data while the output signal, "MSEL", is LOW (indicates that the data was successfully received). The refresh timing will be slightly advanced or delayed, depending on the data receive timing of the central device (G9001). However, when "MSEL" changes from LOW to HIGH, the I/O device must have already read the received data. Therefore, if you want to use the received data by another external device, take out the data during MSEL is HIGH so that you can get reliable data.

5-4-4. Input data set timing

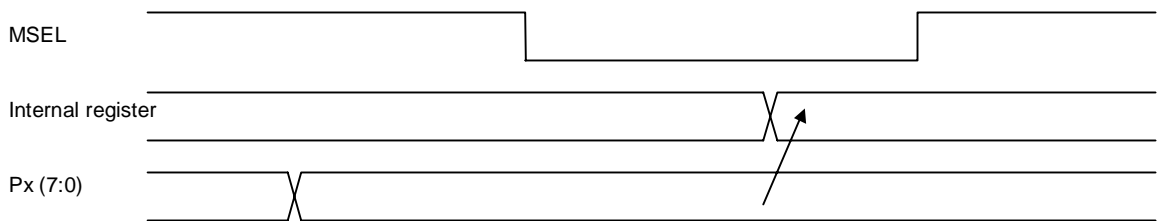

The I/O device reads the data input on the ports using basically the same timing for the output data. It sends the data it receives to the central device (G9001) in the next cyclic communication. The I/O device reads the data on its input lines while MSEL is LOW. To send it data from outside, do so while MSEL is HIGH, so that the I/O device will be looking at stable data when the signal goes LOW again. Also, unless it is receiving cyclic communications from the central device (G9001) normally, the I/O device (G9002) will not read data that is sent to its input ports.

6. External dimensions

80-pin, LQFP, Unit: mm

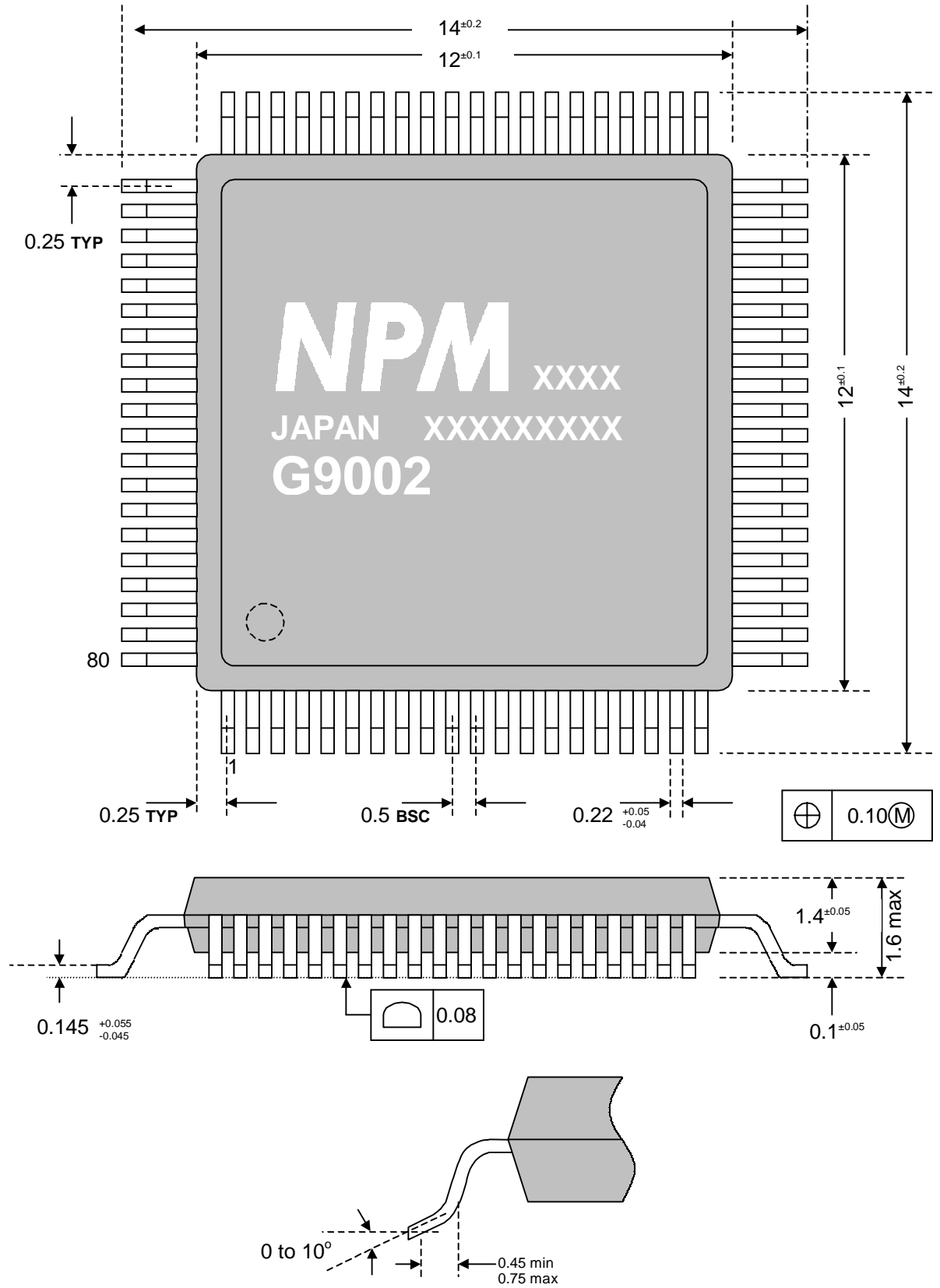

III. Connection Examples and Recommended Environments

G9000 Series

1. Connection examples

1-1. An example of a circuit to interface a CPU to a central device

Four modes are available for connecting a CPU to the central device.

Shown below is an example for connecting a CPU to the IF0 and IF1 terminals.

Please note that the CPU shown in the connection example below is only a representative example.

If the interface is similar, CPUs other than the one shown below may be connected in this fashion.

For details, see the hardware instructions for the CPU you are using.

1-1-1. I/F mode 4 (IF1 = H, IF0 = H)

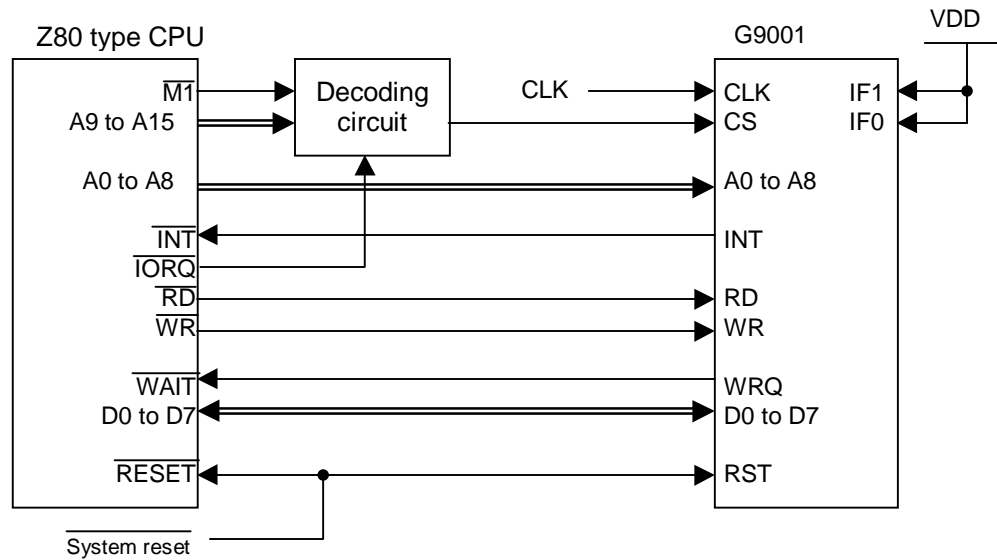

Note 1: When you use an interrupt controller, the CPU will output IORQ as an interrupt acknowledge signal that is used to determine the interrupt vector. At this time, when this LSI's CS terminal goes LOW, the LSI may output a WRQ signal and still not be able to capture the vector properly. Therefore, arrange the decoding circuit so that it only functions when the $\overline{M1}$ signal is HIGH.

Note 2: Pull up terminals D8 to D15 to VDD externally (5 to 10 k-ohms).

Note 3: When you only need to control 8 bytes, without using the complete address map, the address signals can be handled as follows:

A3 to A15: Connect these lines to the decoding circuit and use them to create the CS signal.

A0 to A2: Connect these lines to A0 to A2 on the central device.

Connect A3 to A8 on the central device to GND.

1-1-2. I/F mode3 (IF1=H, IF0=L)

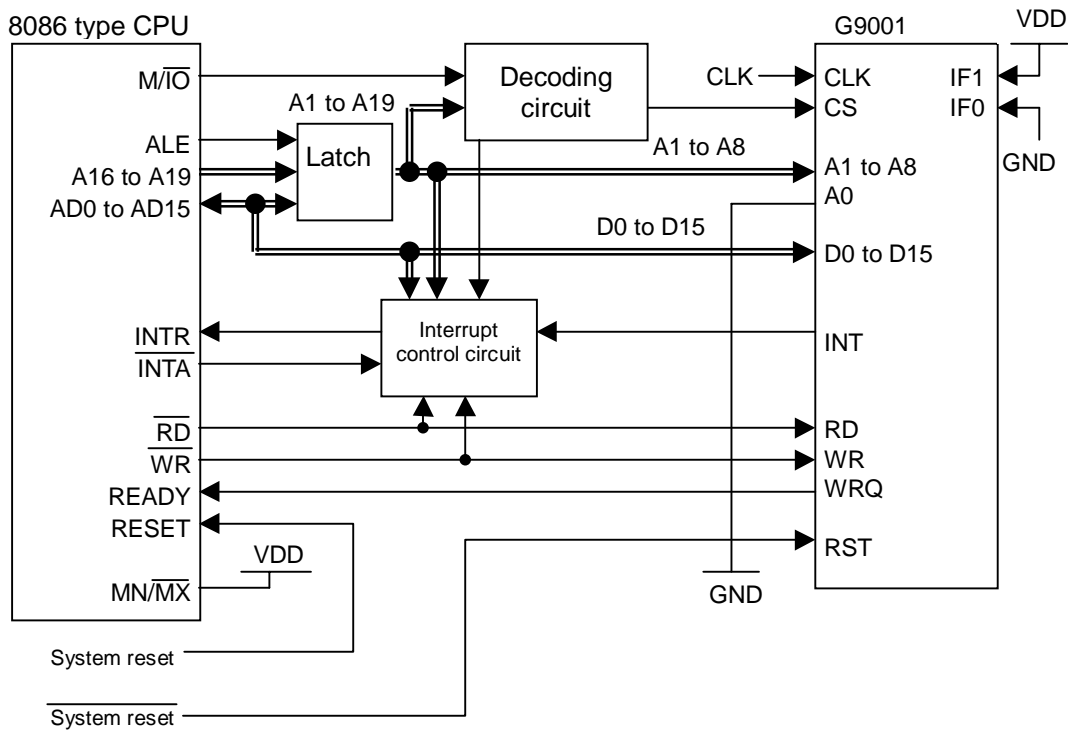

- Note 1: When you only need to control 8 bytes, without using the complete address map, the address signals can be handled as follows:
 ("Address signal" as used in this example refers to signals output from the latching circuit.)
- A3 to A19: Connect these lines to the decoding circuit and use them to create the CS signal.
 - A0 to A2: Connect these lines to A0 to A2 on the central device.
Connect A3 to A8 on the central device to GND.

1-1-3. I/F mode 3 (IF1 = L, IF0 = H)

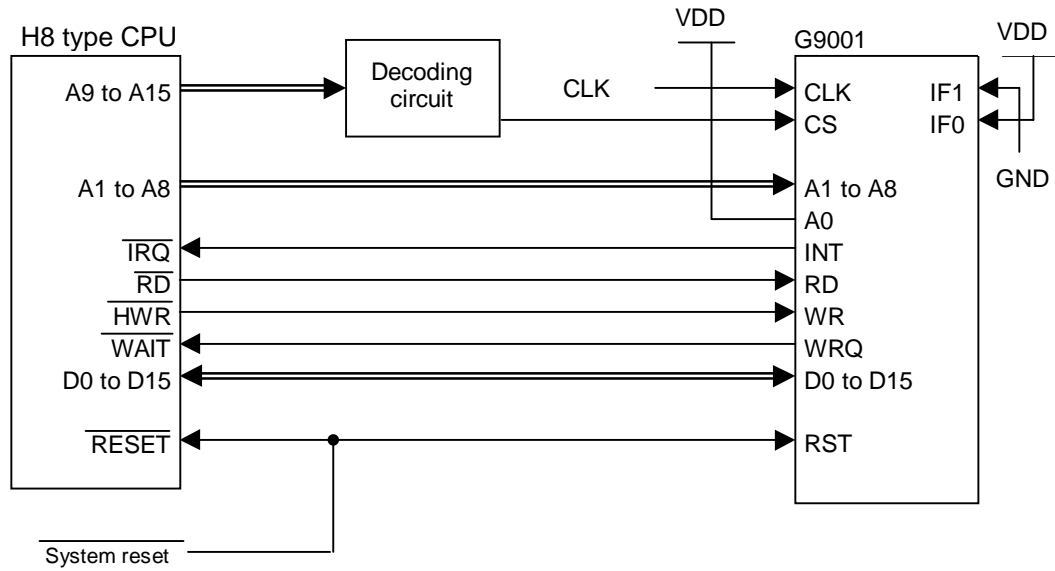

Note 1: When you only need to control 8 bytes, without using the complete address map, the address signals can be handled as follows:

- A3 to A15: Connect these lines to the decoding circuit and use them to create the CS signal.
- A0 to A2: Connect these lines to A0 to A2 on the central device.
A3 to A8 on the central device should be pulled up.

1-1-4. I/F mode 1 (IF1 = L, IF0 = L)

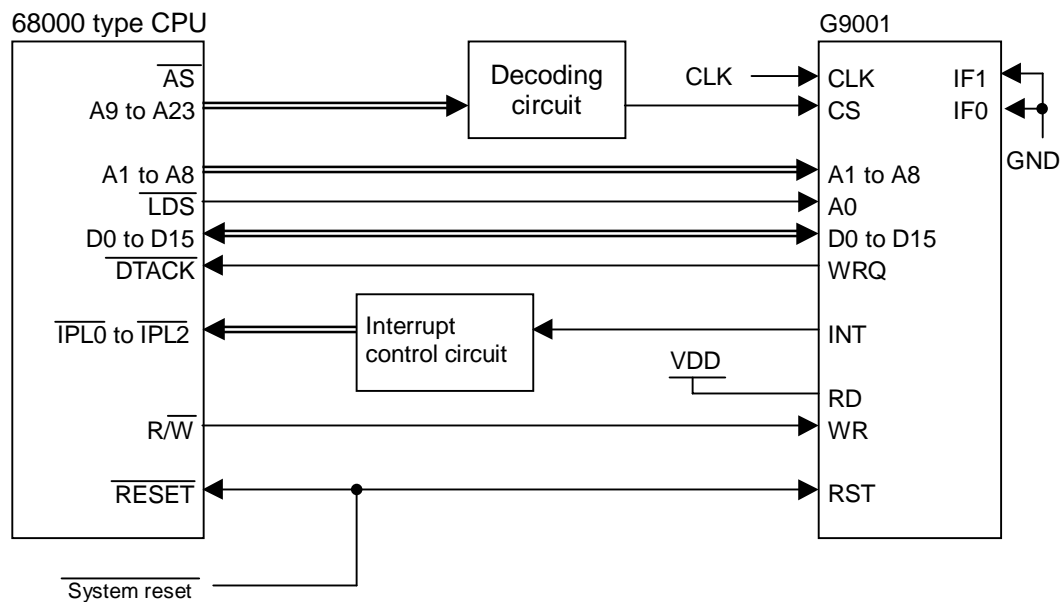

Note 1: When you only need to control 8 bytes, without using the complete address map, the address signals can be handled as follows:

- A3 to A23:** Connect these lines to the decoding circuit and use them to create the CS signal.
- A0 to A2:** Connect these lines to A0 to A2 on the central device. A3 to A8 on the central device should be pulled up.

1-1-5. Connecting to a CPU without a wait function

The central device can be connected to a CPU that does not have a wait function. Lets look at an example with the CPU interface using I/F mode 4 while it is connected to an Intel 8031 8-bit CPU. Since this CPU does not have a terminal for executing a wait function, care is needed when programming.

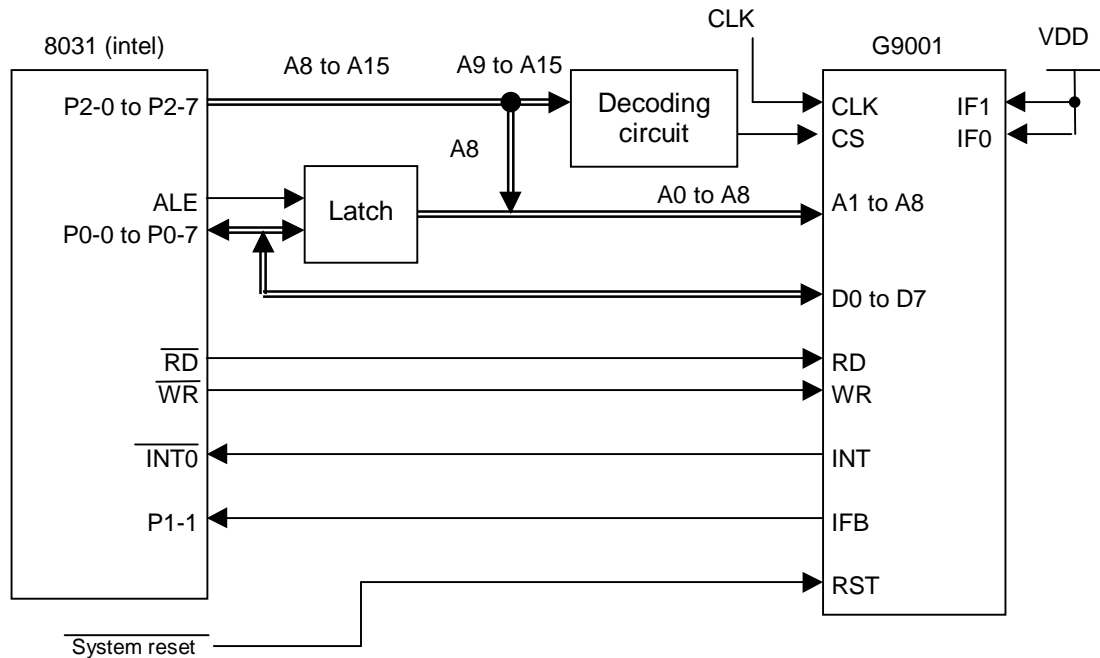

[Points]

- 1) Set IF1 = H and IF0 = H (I/F mode 4).
- 2) Since the 8031 does not have a wait terminal, the WRQ terminal cannot be used. However, some waiting time is needed to be able to access the central device (since it takes some time to finish processing a command), and a wait function is therefore essential for continuous access operations. In the example above, the "IFB" output terminal on the central device is connected to a port on the 8031. The IFB bit is monitored using a routine in the 8031, so that the 8031 does not try to access the central device while it is processing a command.

Note 1: When you only need to control 8 bytes, without using the complete address map, the address signals can be handled as follows:

A3 to A15: Connect these lines to the decoding circuit and use them to create the CS signal.

A0 to A2: Connect these lines to A0 to A2 on the central device.

A3 to A8 on the central device should be connected to GND.

Note 2: Pull up D8 to D15 to VDD externally (5 to 10 K-ohms).

1-2. Access timing

1-2-1. Normal access

The central device has 9 address terminals used to access 512 bytes of memory. The access timing for each of these addresses is shown below.

CPUs that have a wait function can be connected to the WRQ terminal on the central device so that they can be used without special concern for signal timing.

However, CPUs without a wait function must monitor the IFB output or use one of the following timing schemes (this is essential).

1-2-1-1. Write to the I/O buffer or the data transfer FIFO

The timing for writing to the I/O buffer (address 4 and 5 when I/F mode 4) or the data transfer FIFO (address 6 and 7 when I/F mode 4) is shown below.

A wait time is necessary to perform continuous writing. The wait must be 4 clock cycles or longer at 40 MHz.

1) Does not use the WRQ output (CPU does not have a wait function)

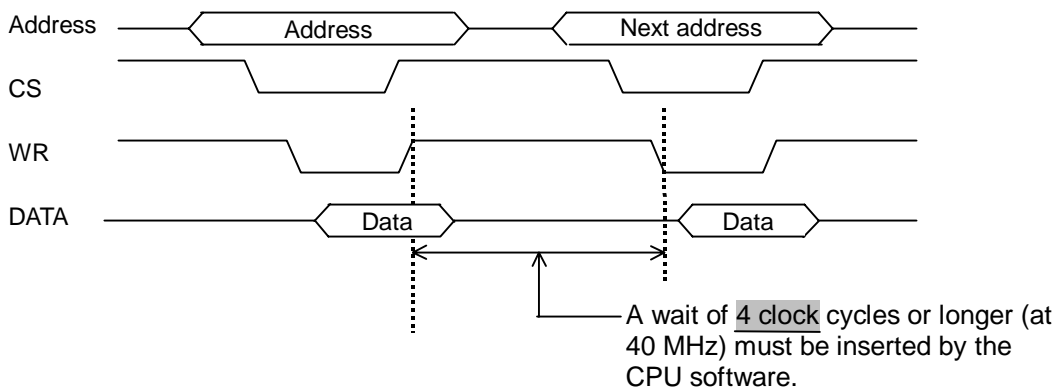

2) Uses the WRQ output (CPU has a wait function)

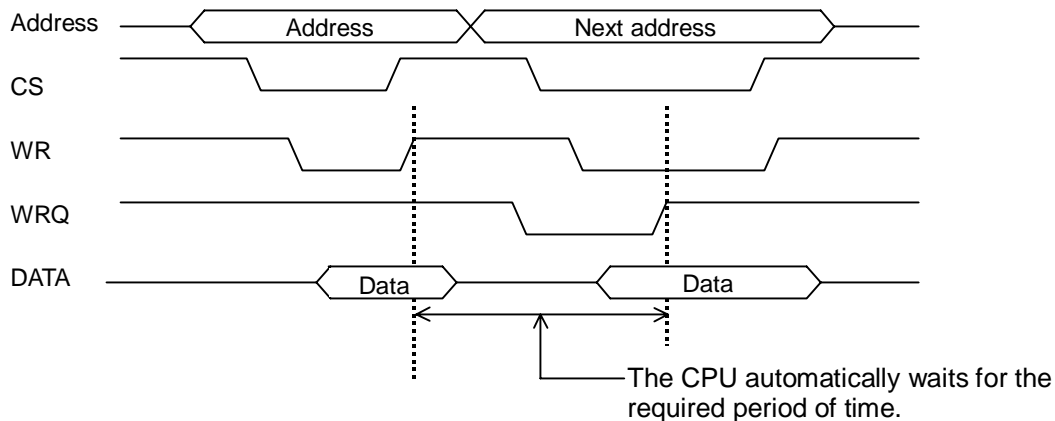

1-2-1-2. Writing to a memory address

The timing for writing to the memory area (078h to 1FFh with I/F mode 4) is shown below. A wait time is necessary to perform continuous writing. The wait must be 6 clock cycles or longer at 40 MHz.

1) Does not use the WRQ output (CPU does not have a wait function)

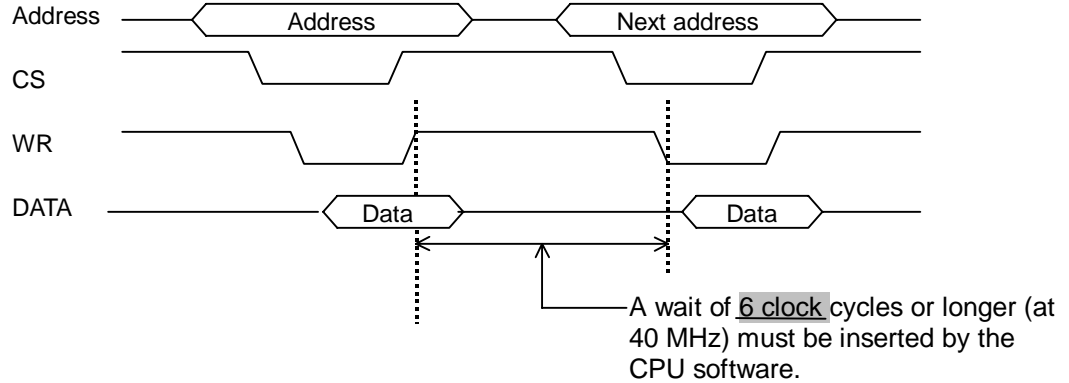

2) Uses the WRQ output (CPU has a wait function)

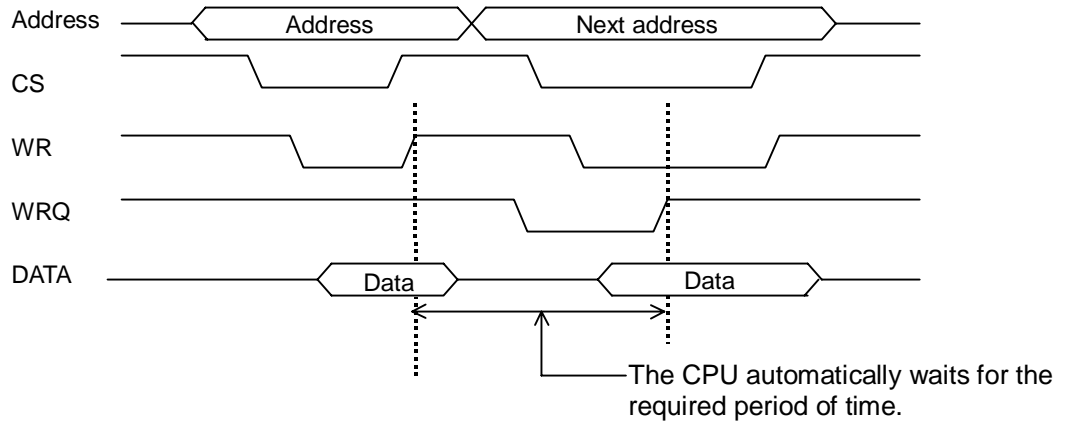

1-2-1-3. Read timing

The data read timing for reading the status (addresses 0 and 1 when the I/F mode = 4), the data receive FIFO, (addresses 6 and 7 when the I/F mode = 4), and the memory area (078h to 1FFh when the I/F mode = 4) is shown below. When reading the I/O buffer (addresses 4 and 5 when the I/F mode = 4), no waiting time is needed.

A wait of 4 clock cycles is needed for continuous reading at 40 MHz.

1) Does not use the WRQ output (CPU does not have a wait function)

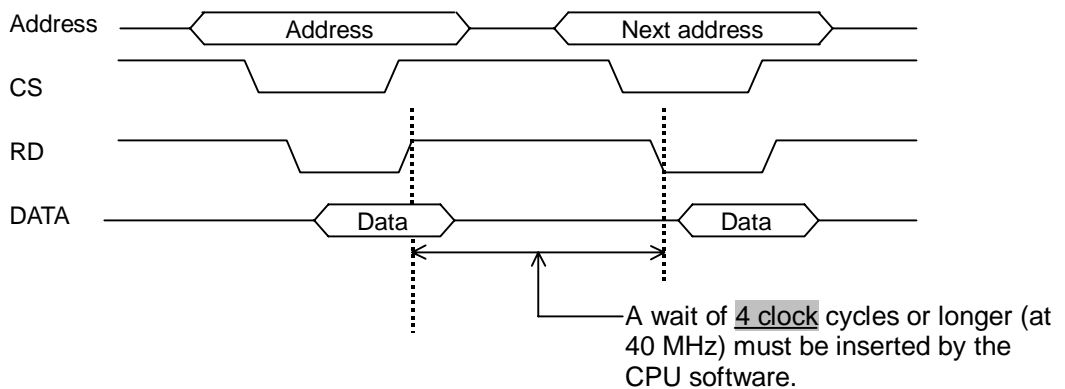

2) Uses the WRQ output (CPU has a wait function)

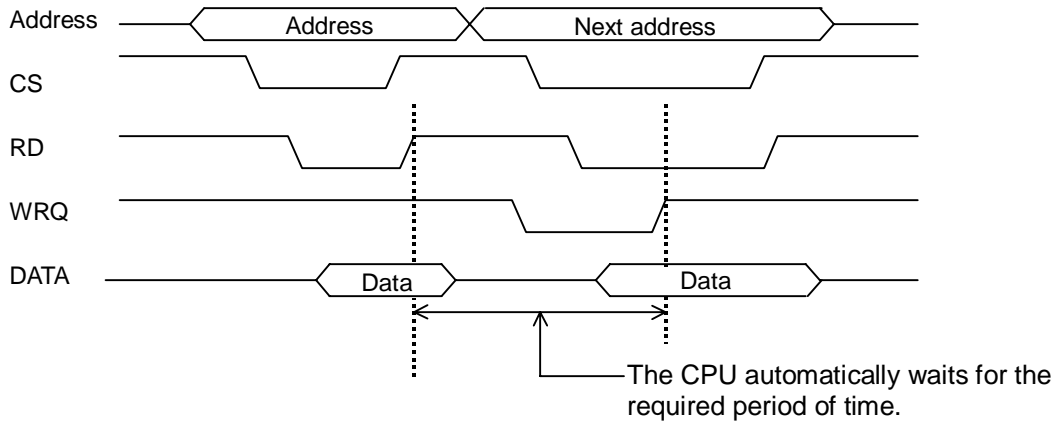

Note: The memory area (078h to 1FFh when the I/F mode = 4) is shared with the internal serial reception circuit. In order to prevent a conflict between reading by a CPU and the internal timing, the central device transfers data from the memory area (internal RAM) to an indirect reading buffer, and then reads the data from this buffer. In order to secure the necessary data transfer time (2 clock cycles at 40 MHz), the central device outputs WRQ = L in response to RD = L, when reading the memory area. Please note the output delay time for reading data. (For details about the output delay time, see section 7-4, "AC characteristics" in the G9001 manual.)

1-2-2. Access by commands

The central device has 9 address terminals used to access 512 bytes of memory. The access timing for each of these addresses is shown below.

However, for certain CPUs, this amount of memory is not directly available.

In this case, just use three address terminals to access 8 bytes in the central device. When addressing in this fashion, commands are used to access addresses beyond the basic 8 bytes.

The access timing used to access the memory area in the central device with commands is different from the method used for direct memory address.

However, CPU's with a wait function don't need to be aware of these timing requirements, since they use the WRQ terminal on the central device.

For CPUs that don't have a wait function, monitor the IFB output or use software to observe the timing described below (this is essential).

1-2-2-1. Write operation command

The operation commands shown below (commands that don't need data, such as Start and Stop) use the write timing to write continuously to the command area (address 1 when the I/F mode = 4).

They must wait 8 clock cycles or longer to perform continuous writing at 40 MHz.

1) Does not use the WRQ output (CPU does not have a wait function)

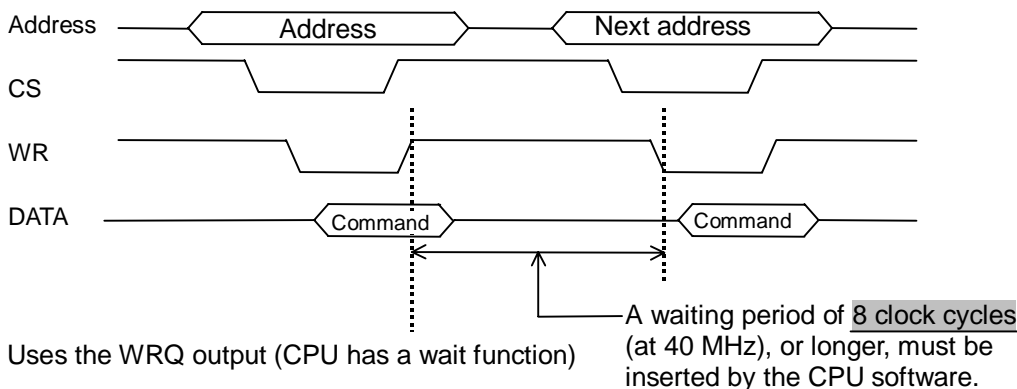

2) Uses the WRQ output (CPU has a wait function)

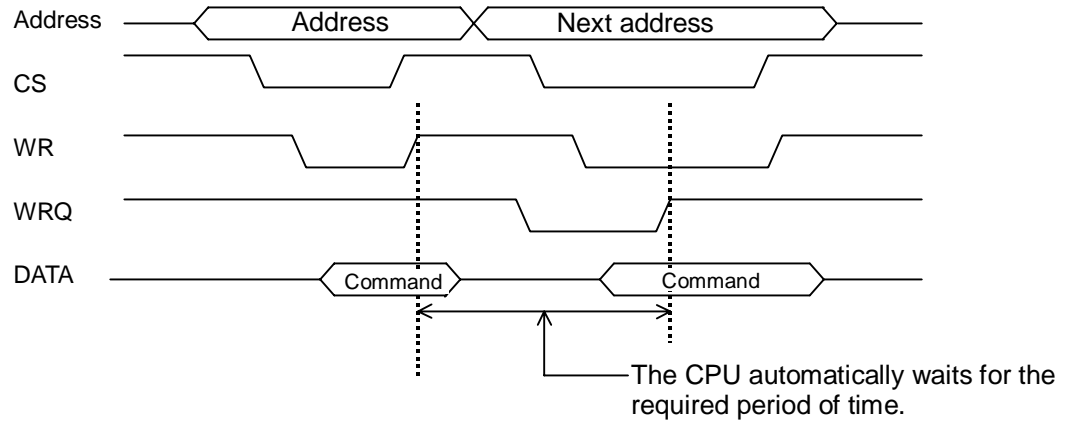

1-2-2-2. Write data to memory using write commands

The write commands can be used to write data to certain memory areas. Shown below is the write timing when I/F mode 4 is selected.

- Intervals of 4 clock cycles at 40 MHz are needed to write data into the I/O buffer or to write write-commands into the command area.
- The following operations (both read and write) require intervals of at least 8 clock cycles at 40 MHz.
- The data can be written in any order. However, the commands must be written in low-bit, high-bit order.

* When the WRQ terminal is connected to the wait terminal on a CPU, the timing is controlled automatically by the CPU's wait control function.

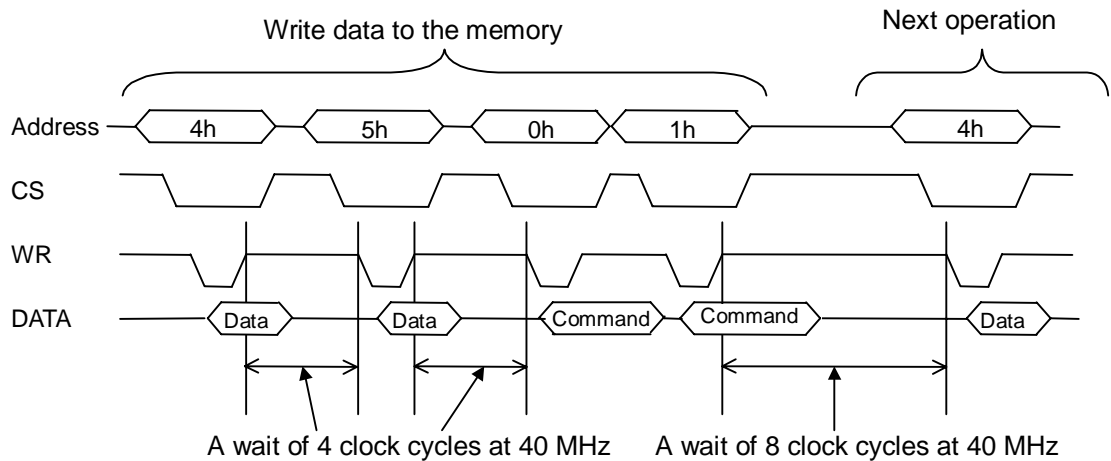

1-2-2-3. Read data from memory using read commands

Use read commands to read data from certain memory areas.
The read timing when I/F mode 4 is selected is shown below.

- After writing a read command, the central device reads data from the I/O buffer. After a read command is sent, the central device needs an interval of 8 reference CLK cycles (at 40 MHz) before the data can be read by the CPU.
- When reading data from the I/O buffer, there is no restriction on the timing. It can be read in any order.
- Read commands must be written low-bit to high bit order.

* When the WRQ terminal is connected to the wait terminal on the CPU, the timing is controlled automatically by the CPU's wait control function.

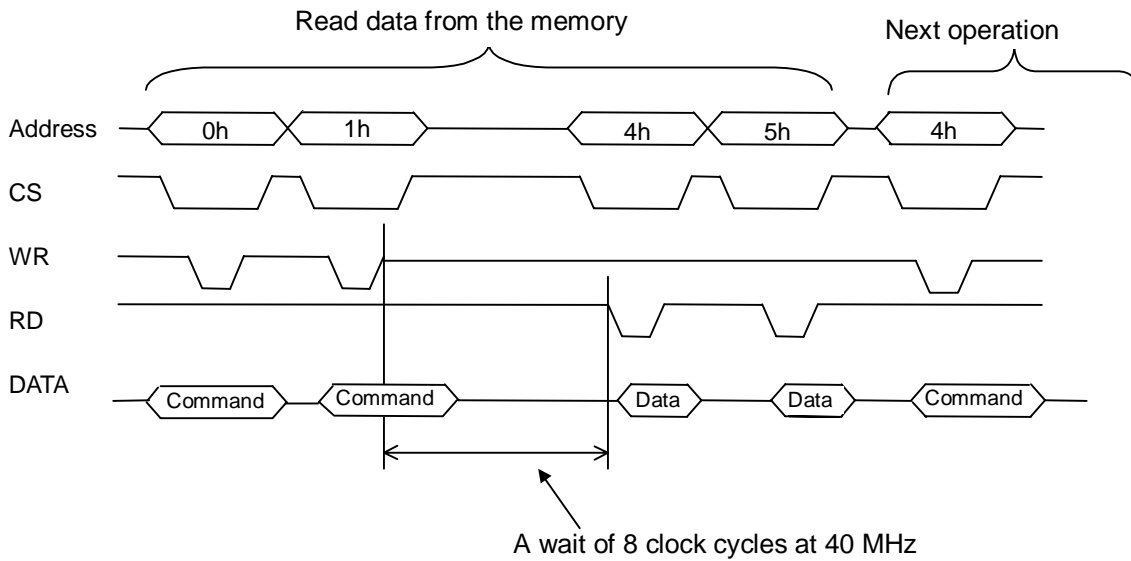

1-3. Line transceiver and pulse transformer for the central device

To make connections for serial communication, use RS-485 line transceivers (driver/receiver) and pulse transformers (1000 μ H or equivalent).

Connect the line transceivers as shown below:

On a transmission line, connect terminating resistors suitable for the cable impedance (100 ohms or similar).

The position of the terminating resistor can be either before or after the pulse transformer. The same effect will be obtained at either position.

When using a 5 V line driver/receiver, ICs such as a level shifter are needed to assert signals on lines such as "SO," "SOEH," and "SI."

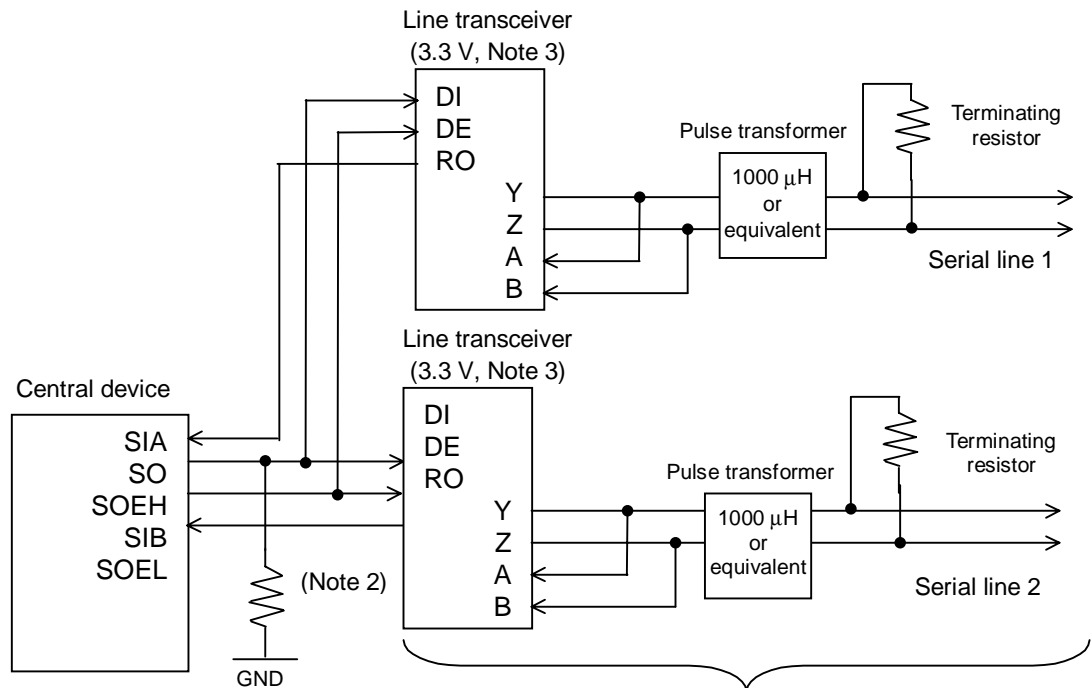

Note 1: When connecting the serial lines to line transceivers, make the path as short and straight as possible.

Serial line 1 and serial line 2 are identical, except for their serial signal input terminals on the central device (SIA and SIB).

In order not to load the lines too heavily, two identical line inputs are provided.

If there are only a few local devices and the serial line is relatively short, a single one of the input lines named above will be enough to maintain a reliable signal.

If you will not be using one or the other of the two inputs (SIA or SIB), connect the unused terminal (SIA or SIB) to VDD or GND.

Note 1: When connecting the serial lines to line transceivers, make the path as short and straight as possible.

Running these lines on a PC board could deteriorate the communication performance.

Note 2: Pull down resistors to GND, should be 5 to 10 k-ohms.

Note 3: The following ICs can be used as 3.3 V line transceivers.

Ex.: (1) ADM3491AN (DIP) or ADM3491AR (SOIC) made by ANALOG DEVICES Corporation

(2) MAX3362EKA (SOT) made by MAXIM Corporation

1-4. Line transceivers and pulse transformers for local devices

Use RS-485 line transceivers and pulse transformers (1000 μ H or equivalent) to make serial communication connections.

Connect the line transceivers as shown below.

Connect terminating resistors (which match the cable impedance) at both ends of the transmission line.

The terminating resistors can be either before or after the pulse transformer. The same effect will be obtained at either position.

When using a 5 V line driver/receiver, ICs such as a level shifter are needed to assert signals on lines such as "SO," "SOEH," and "SI."

(1) Circuit example for a single local device

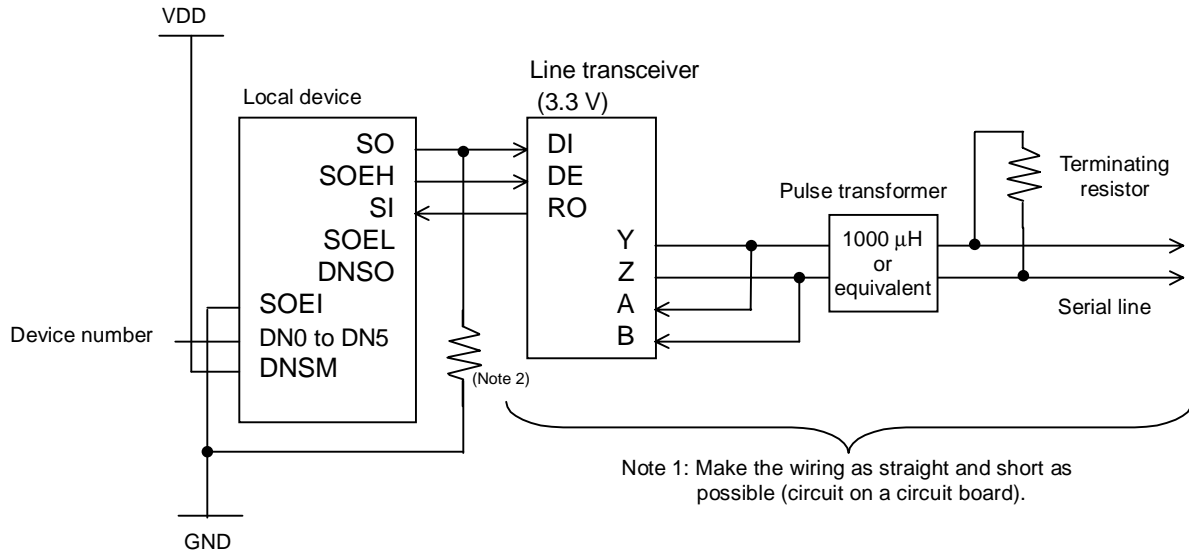

(2) Circuit example for multiple local devices

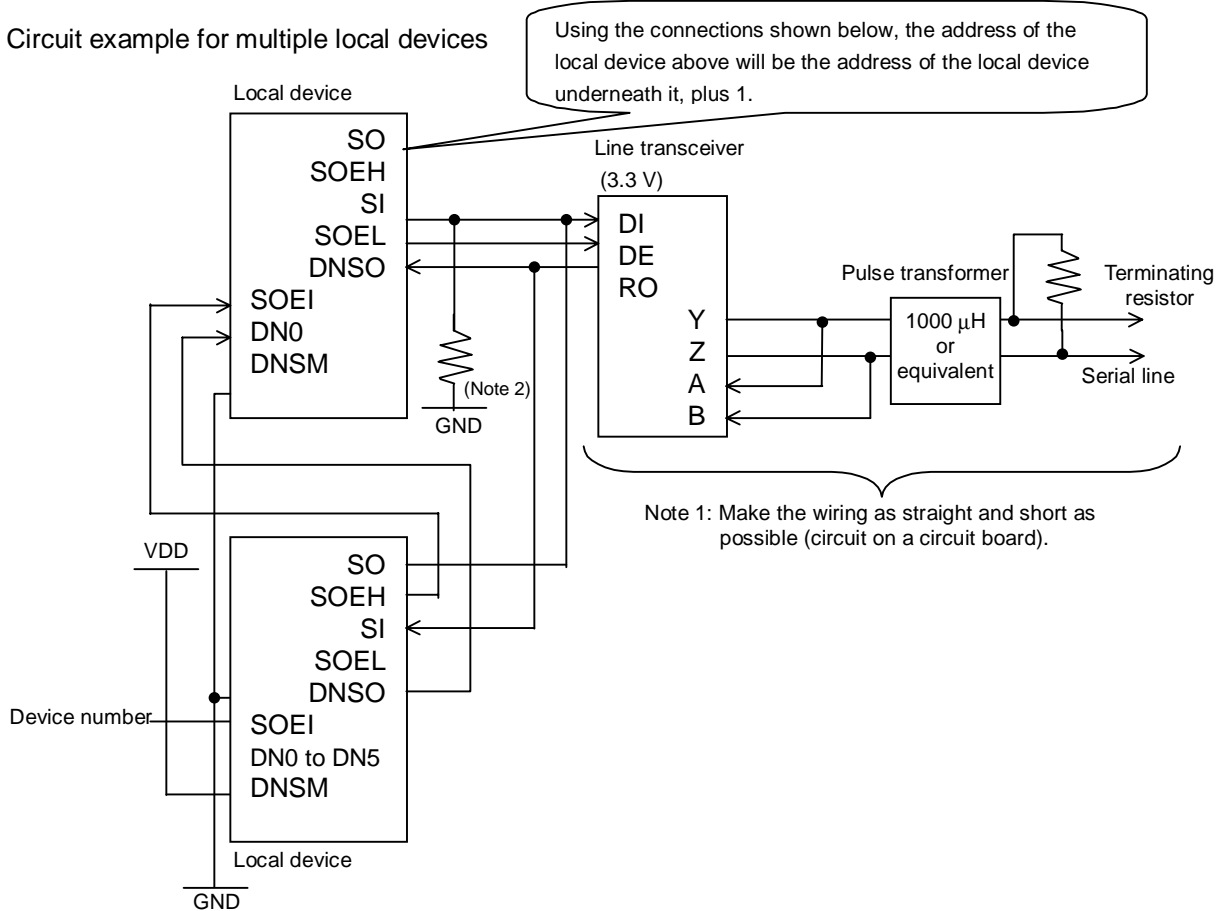

Note 2: The pull down resistor to GND should be 5 to 10 k-ohms.

1-5. A connection example of a level shifter

When using a 5 V line transceiver, a level shifter is needed. Shown below is an example of the connections for a level shifter (TI: SN74LVC244A) and a line transceiver (TI: SN75LBC180A).

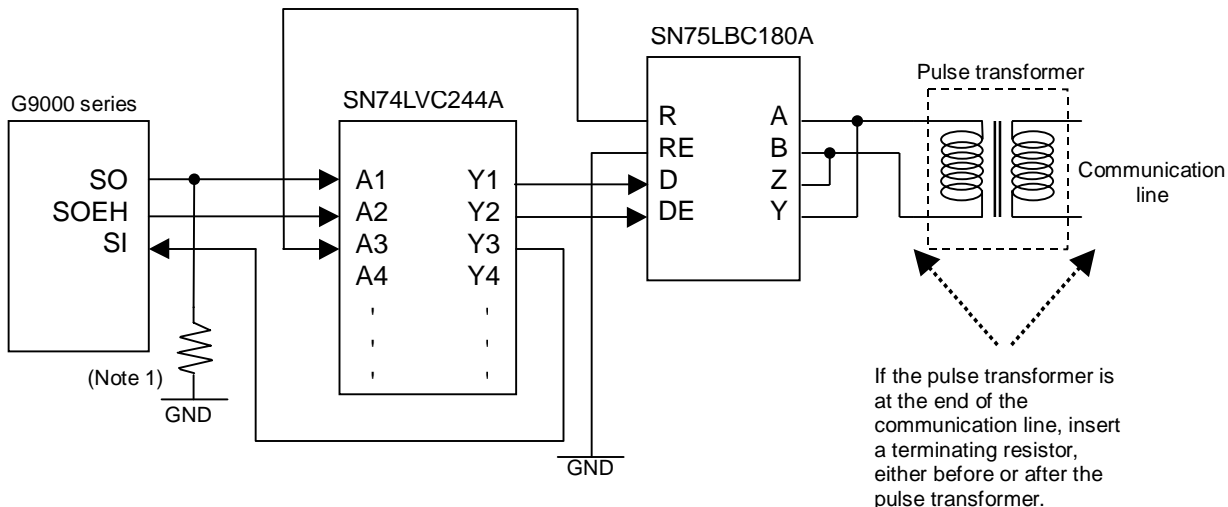

1-6. Complete configuration

We recommend a configuration with the central device at one end of the line and the local devices at other end, as shown below.

If you want to place the central device in the middle of the line, use two communication lines so that the central device is effectively at the end of each line.

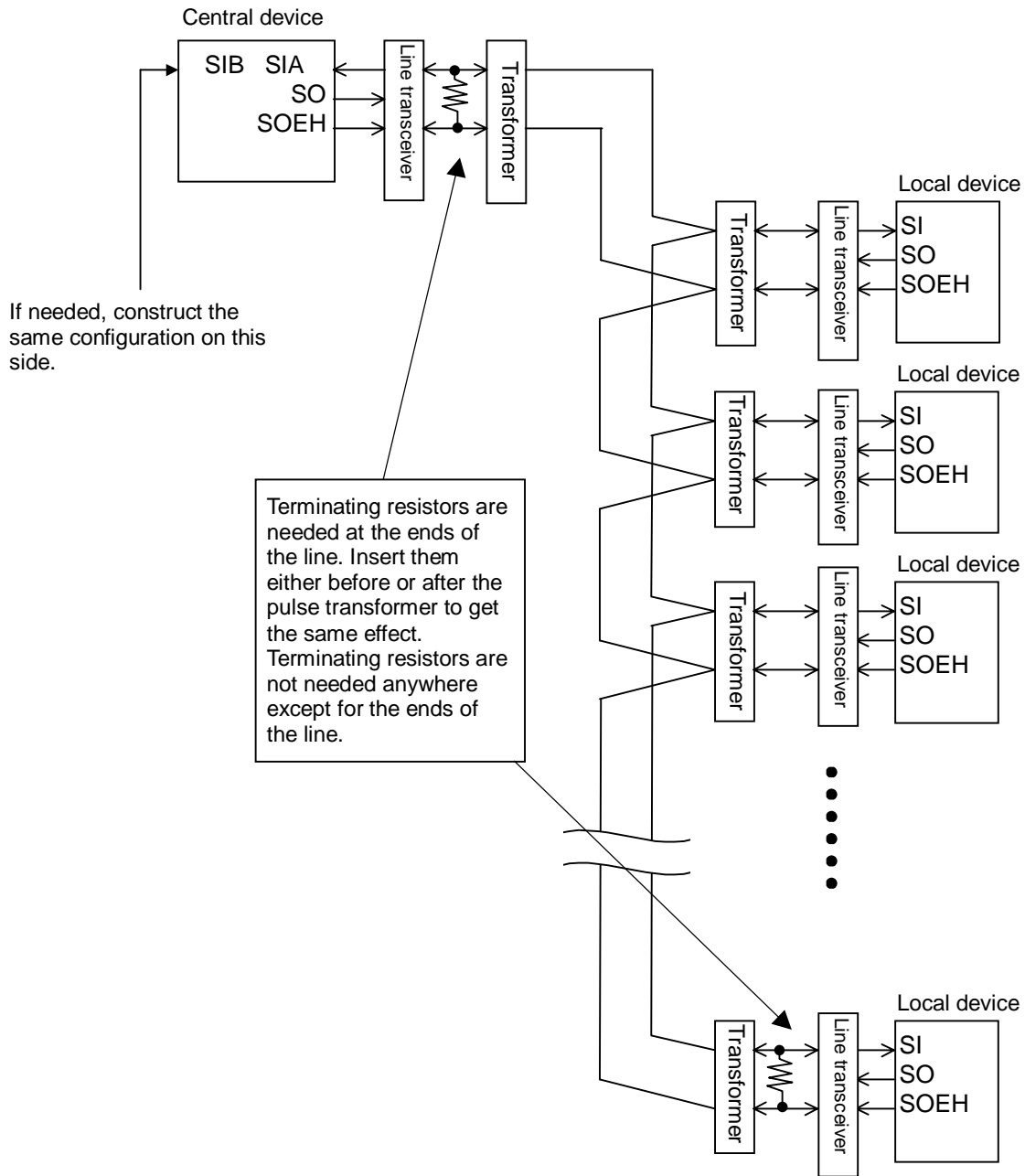

2. Recommended environment

Shown below are the results of our experimental communication results and the environment used for the experiment.

These results can be used to design your own system. However, other system configurations are possible. The example below is only for your reference.

Conditions						Results
Transmission rate	Number of local devices	Cable used	Terminating resistor	Pulse transformer	I/F chip	Max. length
20 Mbps	32	CAT5	100 ohm	1000 μ H	RS485	100 m
20 Mbps	64	CAT5	100 ohm	1000 μ H	RS485	50 m
10 Mbps	64	CAT6	100 ohm	1000 μ H	RS485	100 m

Note: In the figures above, the maximum length figures are results from ideal conditions in a laboratory. In actual use, the results may not be the same.

2-1. Cable

Commercially available LAN cables were used.

CAT5: Category 5

CAT6: Category 6

We used these LAN cables because they are high quality, cheap, and easy to obtain. Lower quality cables (such as cheap instrument cables) may significantly reduce the effective total length of the line. LAN cables normally consist of several pair of wires. Make sure to use wires from the same pair for one set of communication lines.

Even when using cables with the same category and rating, the performance of each cable manufacturer may be different. Always use the highest quality cables in the same category.

2-2. Terminating resistor

Select resistors that match the impedance of the cable used.

Normally, a 100 ohm resistor is recommended. Therefore, we used terminating resistors with this value.

Adjusting this resistor value may improve the transmission line quality.

2-3. Pulse transformer

We recommend using pulse transformers, in order to isolate the GND of each local device.

By isolating the GNDs, the system will have greater resistance to electrical noise. If pulse transformers are not used, the transmission distance may be less.

We used 1000 μ H transformers in our experiments.

2-4. I/F chip

We selected I/C chips with specifications better than the RS485 standard.

In the experiment, we used 5 V line transceivers. When 5 V line transceivers are used, level shifters are needed to make the connections.

2-5. Parts used in our experiments

Show below is a list of the parts used in the interface circuits of our experiments. Use of other parts may change the system's response. This list is only for your reference.

Parts	Manufacturer	Model name
CAT5	Oki Wire Co., Ltd.	F-DTI-C5 (SLA)
CAT6	Oki Wire Co., Ltd.	DTI-C6X
Pulse transformer	JBC Co., Ltd.	DP101-102F
Line transceiver	TEXAS INSTRUMENTS	SN75LBC180AP
Level shifter	TEXAS INSTRUMENTS	SN74LVC244ADB

2-6. Other precautions

- Cables

When you are planning long distance transmission, cable quality will be the single most important factor.

Specialized cables designed for use as field buses, such as those by CC-Link and LONWORKS, have guaranteed quality and may be easier to use.

- Pulse transformers

Needless to say, the pulse transformers should handle 20 Mbps (10 MHz) without becoming saturated. The transformer's inductance is also important.

Since up to 64 pulse transformers may be connected, the actual working specifications of these devices must be very similar.

We used 1000 μ H pulse transformers. However, in order to obtain better response characteristics, you may want to try pulse transformers with a larger reactance.

- Line transceivers

We used TEXAS Instruments chips for the experiments.

Other possibilities are available from MAXIM and LINEAR TECHNOLOGY, who offer very high performance transceivers.

- Connectors

If possible, the connectors should match the cable characteristics.

Although we did not use them, modular type connectors will be better for LAN cables.

- Cable connections

Do not connect one cable to another cable (using connectors etc.).

In a multi-drop system, the number of cables increases as the number of local devices increase.

However, connecting a cable just to extend the line should be avoided.

- Processing of excess cable

Excess cable, left over after making all the runs, should be eliminated.

Unneeded cable length may restrict the line overall usable length, and may introduce electrical noise.

- Circuit board substrate

Create circuits on a substrate with 4 or more layers, to prevent the introduction of noise.

- Estimating cable length in the system design phase

In the first estimate, use shorter line lengths. In the actual system configuration, lines may be lengthened. Estimates made using the maximum length may lead to impossible communication distances.

- Minimum cable length

Each cable must be at least 60 cm (23-1/2 in) long. Although this may seem contradictory to the excess cable precaution, this minimum length is necessary.

- Using different cables in one system
Do not mix cables from different manufacturers, even when they are in the same category.
(Different cable models from the same manufacturer should not be used either.)
Using different cables together may deteriorate the communication quality.

IV. Software Examples (flow chart)

G9001

1. Assumption

This Chapter outlines software for the central device using flow charts. In the flow charts, required variables are used for convenience.

1-1. Environment and precautions used for the descriptions

The descriptions below assume that I/F mode 3 is selected. Therefore, a 16-bit data bus is used. Address map details are found in item "(2) I/F mode 3", of the "Address Map" section in Chapter 1. The addresses described there will be used in the descriptions in this section. Also, these descriptions are based on the assumption that the wiring connections around the central device have been properly prepared and that the connected local devices are turned on. And, of course, we presume that connections to the serial line and the termination resistances are all correct.

1-2. Commands used

We will use the following two commands to access the address map in the central device.

1) Write command to the central device

Outpw (Address, Data)	
Address	Value corresponding to the address map in the central device The lowest bit is fixed to 0.
Data	Data to write (16 bits)
Return value	None

2) Read command from the central device

Inpw (Address)	
Address	Value corresponding to the address map in the central device The lowest bit is fixed to 0.
Return value	Read data (16 bits)

2. Software Examples

2-1. Start of the simplest cyclic communication

The simplest example is to issue a system communication command, let the central device automatically collect data from the local devices, and then start cyclic communication.

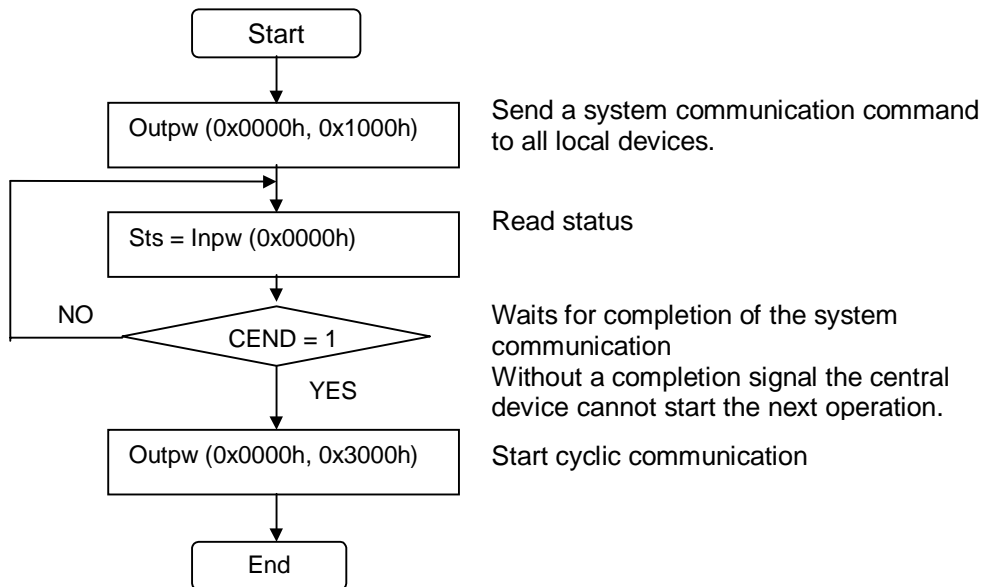

2-2. The central device specifies the data for the local devices that are connected

This method assumes that the data for the local devices is already known and this data is manually specified in the address map of the central device. Then cyclic communication is started. By doing this, mis-settings in local devices can be found rather easily (an error occurs when there is a mis-setting).

For example, assume that the following three devices are connected. (The device numbers shown below are in decimal notation.)

	Local device type	Device No.	Input port	Output ports
1	I/O device	10	Port 0	Port 1 to 3
2	PCL device	11	Port 0 to 2	Port 3
3	I/O device	20	Port 0 to 2	Port 3

Note: The port attributes of the PCL device are fixed. Input ports 0 and 1 contain status information.

1) When the whole address map can be used (all 512 bytes)

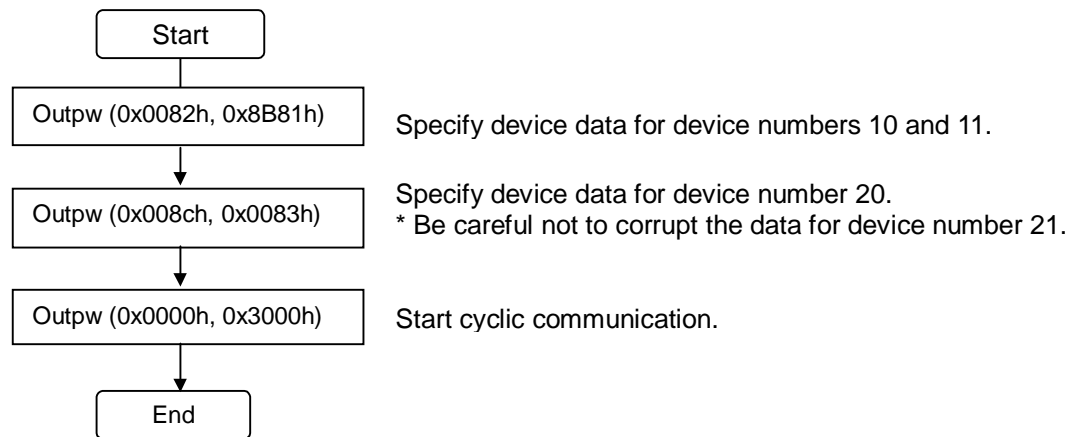

For information about device data values, see section 5-1-2 in Chapter I. With a PCL device, this value is always "8Bh."

2) When using only the lower 8 bytes in the address map

The details in the central device that can be seen by an external CPU are from the command area to the data transmission (reception) FIFOs. Use commands to access other areas.

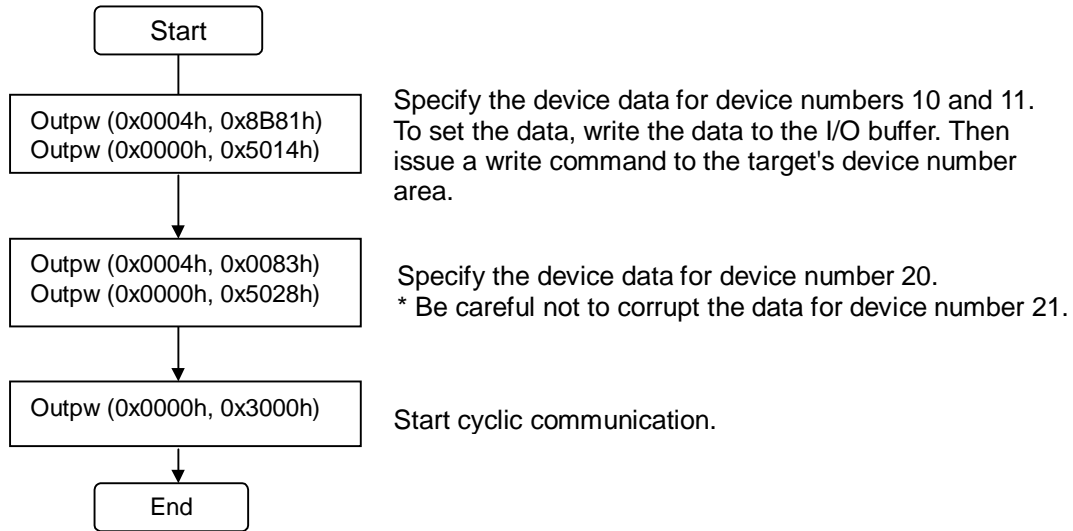

A write command is constructed as follows:

15	14	13	12	11	10	9	8	7	6	5	4	3	2	1	0
0	1	0	1	0	0	0	0	0	#	#	#	#	#	X	&

- Specify the address here
- The lower bit is not used in the address. Leave it at 0.
- Positions marked with "&" are not used. Leave them at 0.

2-3. Set up an input-change interrupt

Assume that the central device wants to detect changes on the ports for the following two local devices.

Device No.	Port numbers to monitor for change
4	Port 0
7	Port 1, Port 2

1) When the whole address map can be used

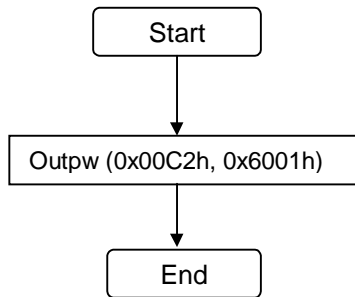

Specify the ports to monitor for device numbers 4 and 7.
 * Be careful not to corrupt the data for device numbers 5 and 6.

In I/F mode 3, address "00C2h" has the following meaning.

Monitor Port "1" and if there is a change on this port, an input-change interrupt will be issued.

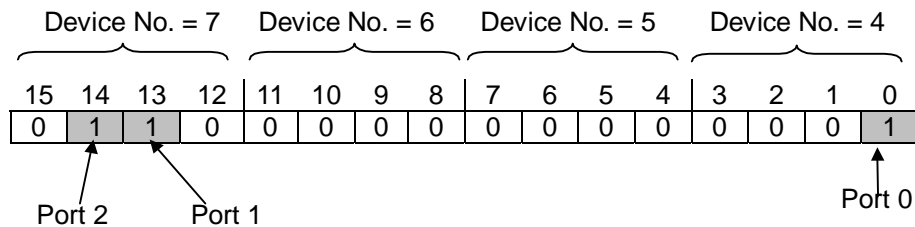

This address also contains a change interrupt setting for parts of device Nos. 5 and 6. In order to prevent problems with the settings for these parts, it is better to read the address and then use a mask.

* An example of how to use a mask to prevent corruption of the settings for device numbers 5 and 6

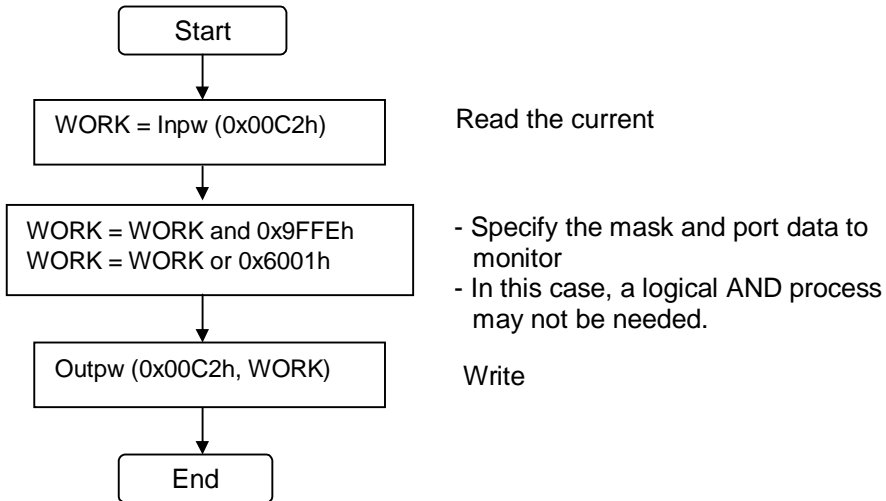

2) When using only the lower 8 bytes in the address map

The central device details that can be seen from an external CPU are from the command area to the data transmission (reception) FIFOs. Use commands to access other areas.

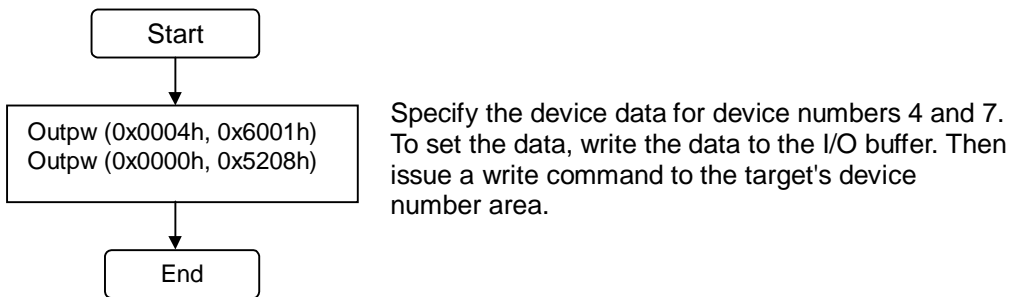

A write command is constructed as follows:

15	14	13	12	11	10	9	8	7	6	5	4	3	2	1	0
0	1	0	1	0	0	1	0	0	#	#	#	#	X	X	&

- Specify the address here
- The lower 2 address bits are not used. Leave them at 0.
- Positions marked with "&" are not used. Leave them at 0.

2-4. Check and clear any existing input-change interrupts

When the port status set in the previous section changes, an input-change interrupt will occur. This section describes how to check and clear this interrupt.

1) When the whole address map is used

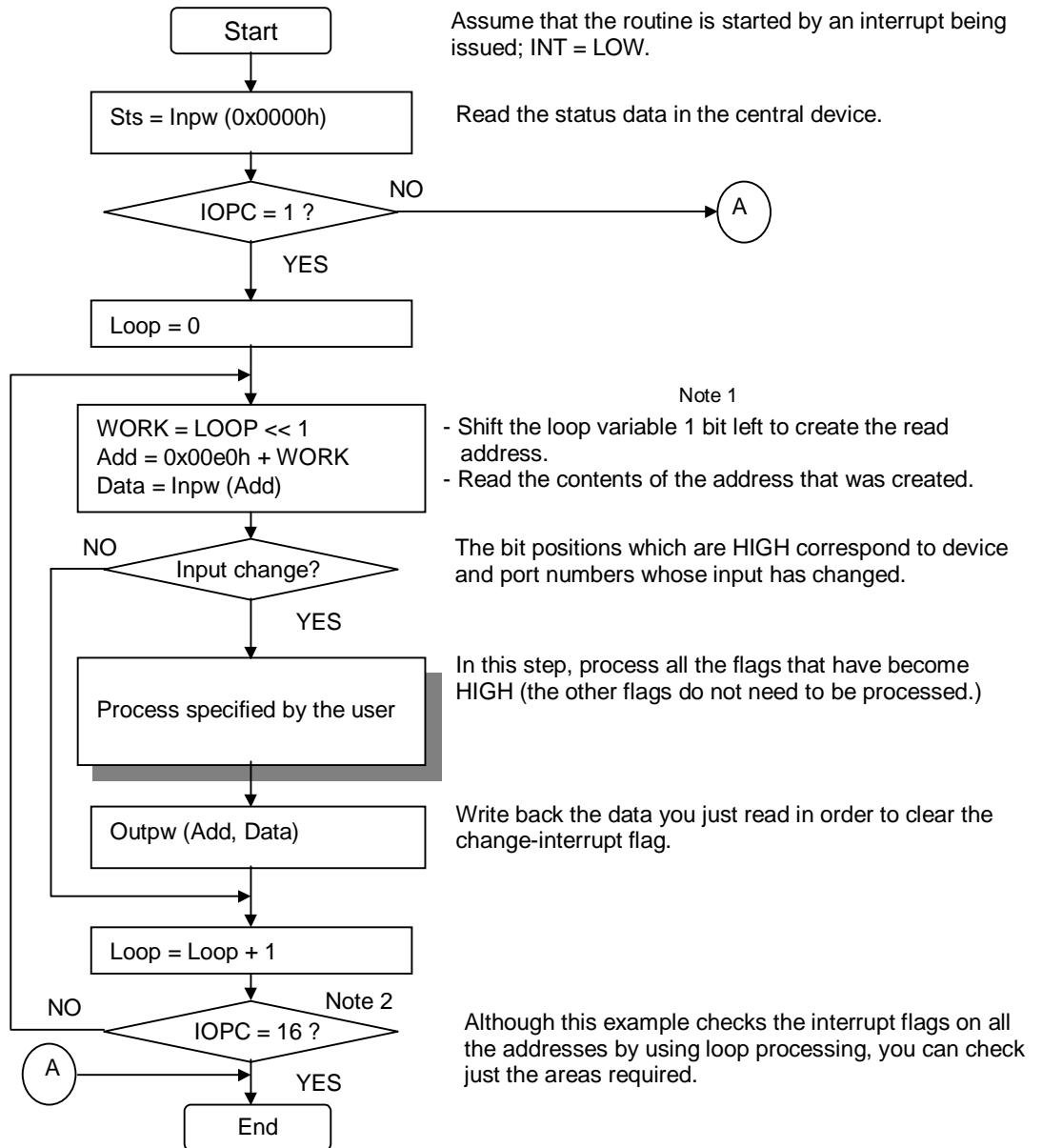

Note 1: In the address creation step above, the program shifts the LOOP variable one bit left (2x). This is because the address number to read increases by 2 each time the loop is executed.

Note 2: The number of loop executions will always be less than 16. This is because one read loop can obtain the data for 4 local devices. (64 / 4 = 16)

2) When using only the upper 8 bytes in the address map

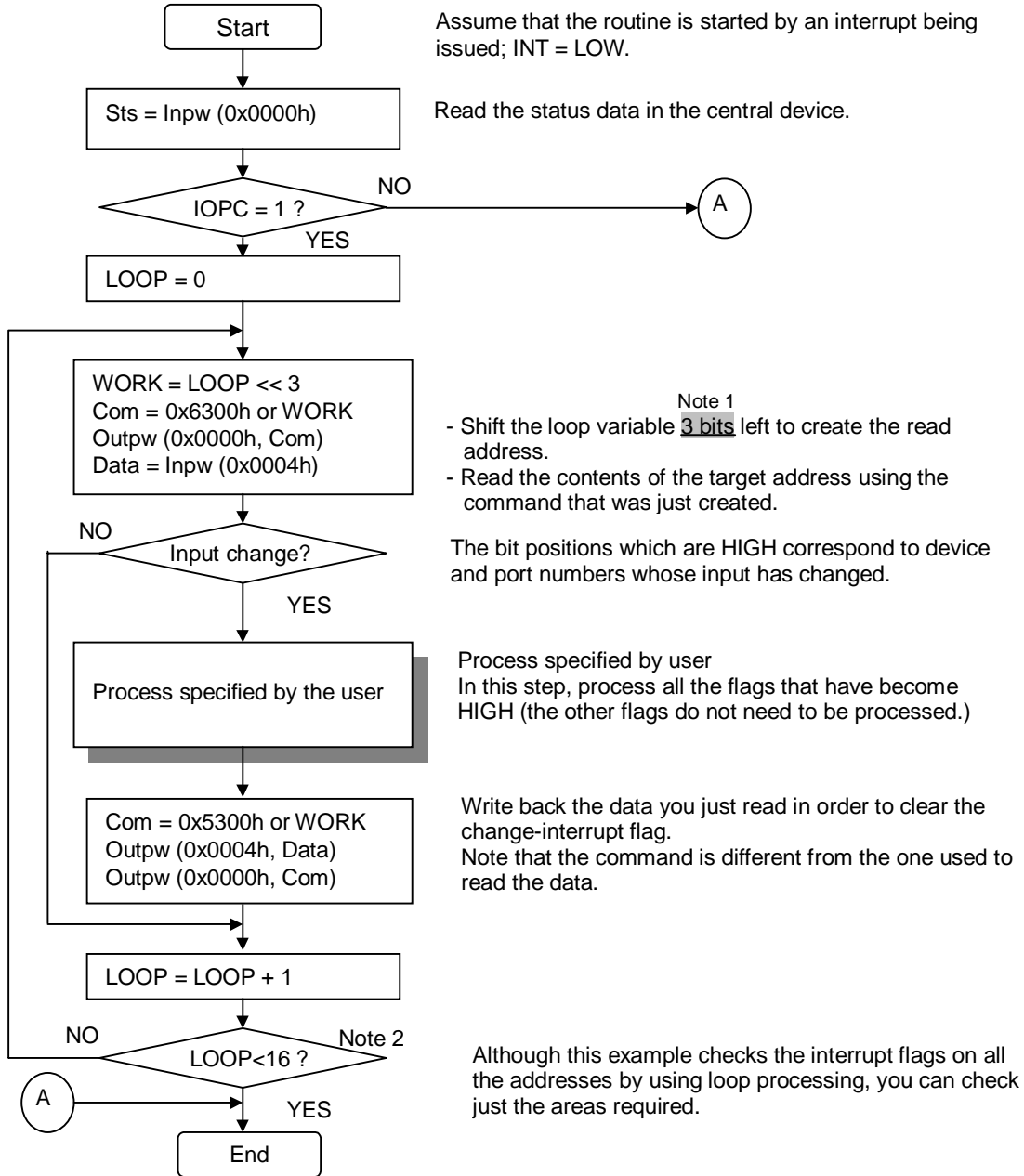

The read command is constructed as follows:

15	14	13	12	11	10	9	8	7	6	5	4	3	2	1	0
0	1	1	0	0	0	1	1	0	#	#	#	#	X	X	&

When writing data used to clear the flags, these bits become "0101."

- Specify the address in these 8 bits.
- The lower 2 bits of the address byte are not used. Leave them at 0.
- The lowest bit (marked with an "&") is empty. Leave it at 0.

Note 1: In the address creation step above, the program shifts the LOOP variable three bits left. This is done to create the command above.

Note 2: The number of loop executions will always be less than 16. This is because one read loop can obtain the data for 4 local devices. (64 / 4 = 16)

2-5. Check and clear I/O communication errors

If the same device number reports the same fault 3 times in a row in cyclic communication, an error occurs. This section describes how to check and clear this I/O communication error.

1) When the whole address map can be used

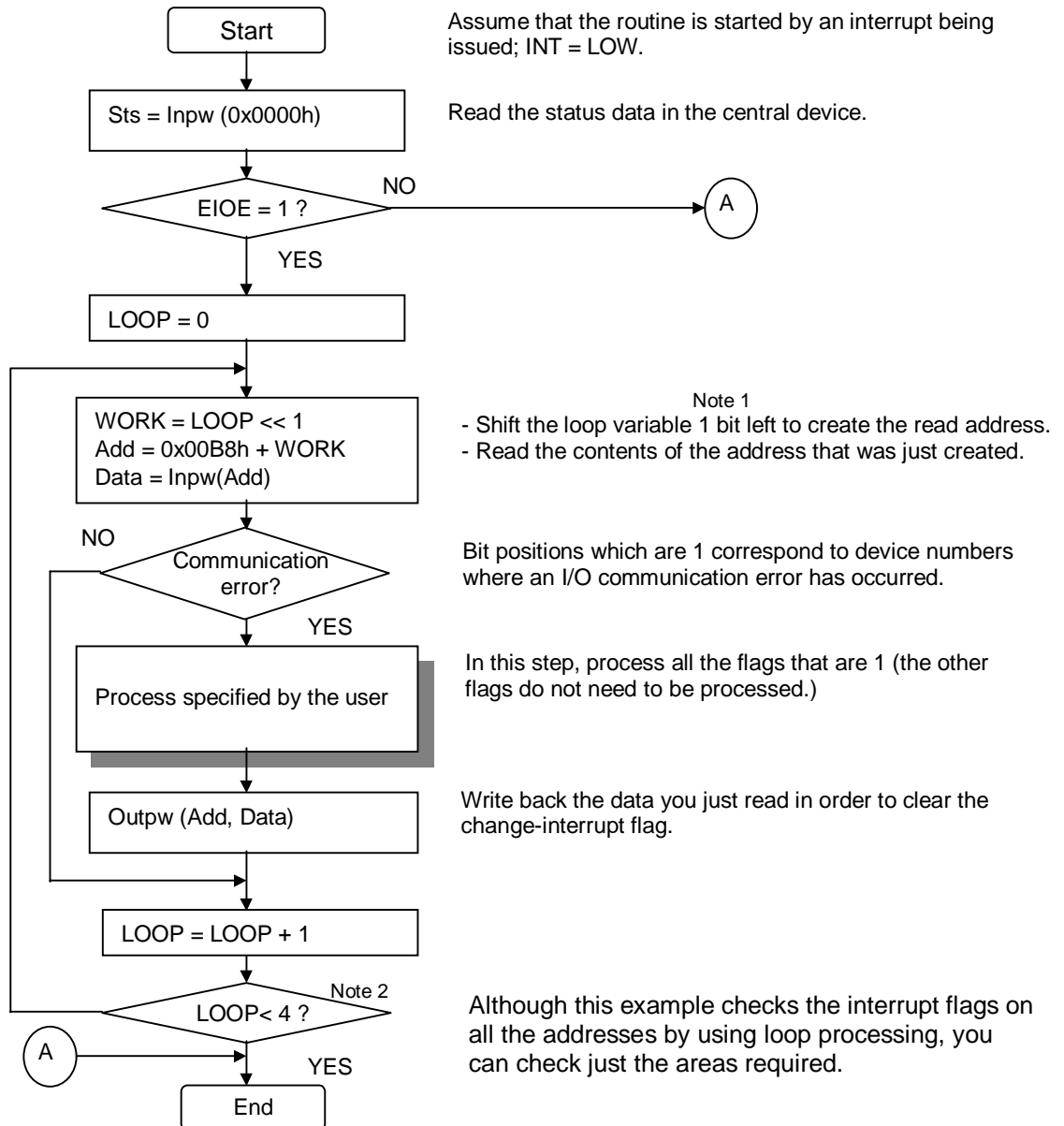

Note 1: In the address creation step above, the program shifts the LOOP variable one bit left (2x). This is because the address number to read increases by 2 each time the loop is executed.

Note 2: The number of loop executions will always be less than 16. This is because one read loop can obtain the data for 4 local devices. (64 / 16 = 4)

2) When using only the upper 8 bytes in the address map

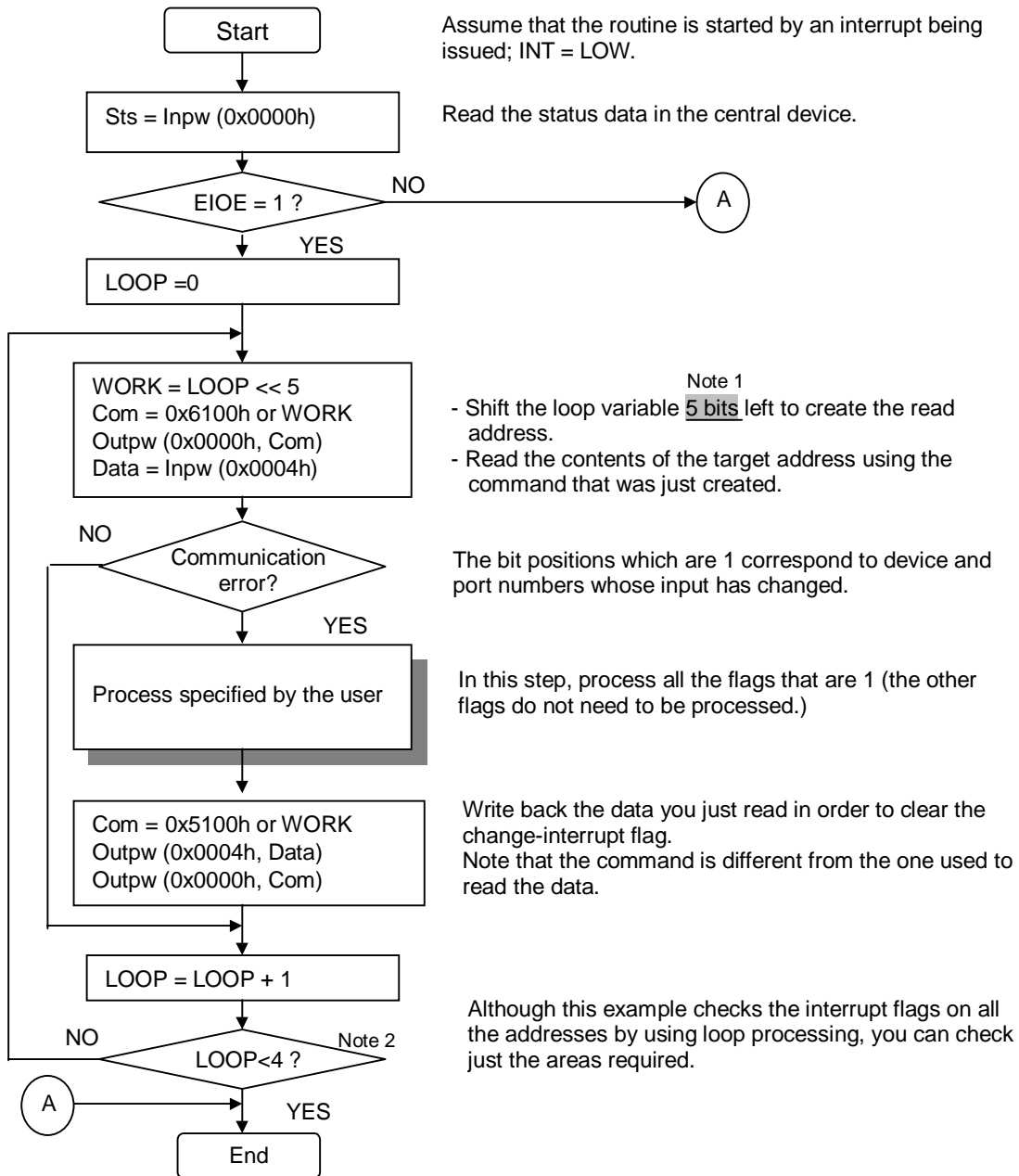

The read command is constructed as follows:

15	14	13	12	11	10	9	8	7	6	5	4	3	2	1	0
0	1	1	0	0	0	0	1	0	#	#	X	X	X	X	&

When writing data used to clear the flags, these bits become "0101."

- Specify the address in these 6 bits.
- The lower 2 bits of the address byte are not used. Leave them at 0.
- The lowest bit (marked with an "&") is empty. (Leave it at 0.)

Note 1: In the address creation step above, the program shifts the LOOP variable five bits left. This is done to create the command above.

Note 2: The number of loop executions will always be less than 16. This is because one read loop can obtain the data for 4 local devices. (64 / 16 = 4)

2-6. Communication with port data (port data and data device status)

This section describes data exchange using the I/O port on an I/O device (G9002), and how to obtain the status of a data device.

Assume that the local devices to be used are as follows:

Only an example of how to read the status is given for the PCL device (G9003).

Device type	Item to configure	Configuration data	Output data
I/O device	Device address	2	-
	Port 0	Input	-
	Port 1	Output	12h
	Port 2	Output	34h
	Port 3	Output	56h
PCL device	Device address	5	

Note: The port area configuration of the PCL device (G9003) is always as follows (fixed).

Port No.	Mode	Description
Port 0	Input	Main status (MSTSB0) lower 16 bits
Port 1	Input	Main status (MSTSB1) upper 16 bits
Port 2	Input	Input value from the general-purpose I/O port (IOPIB)
Port 3	Output	Output value to the general-purpose I/O port (IOPIB)

1) When the whole address map can be used

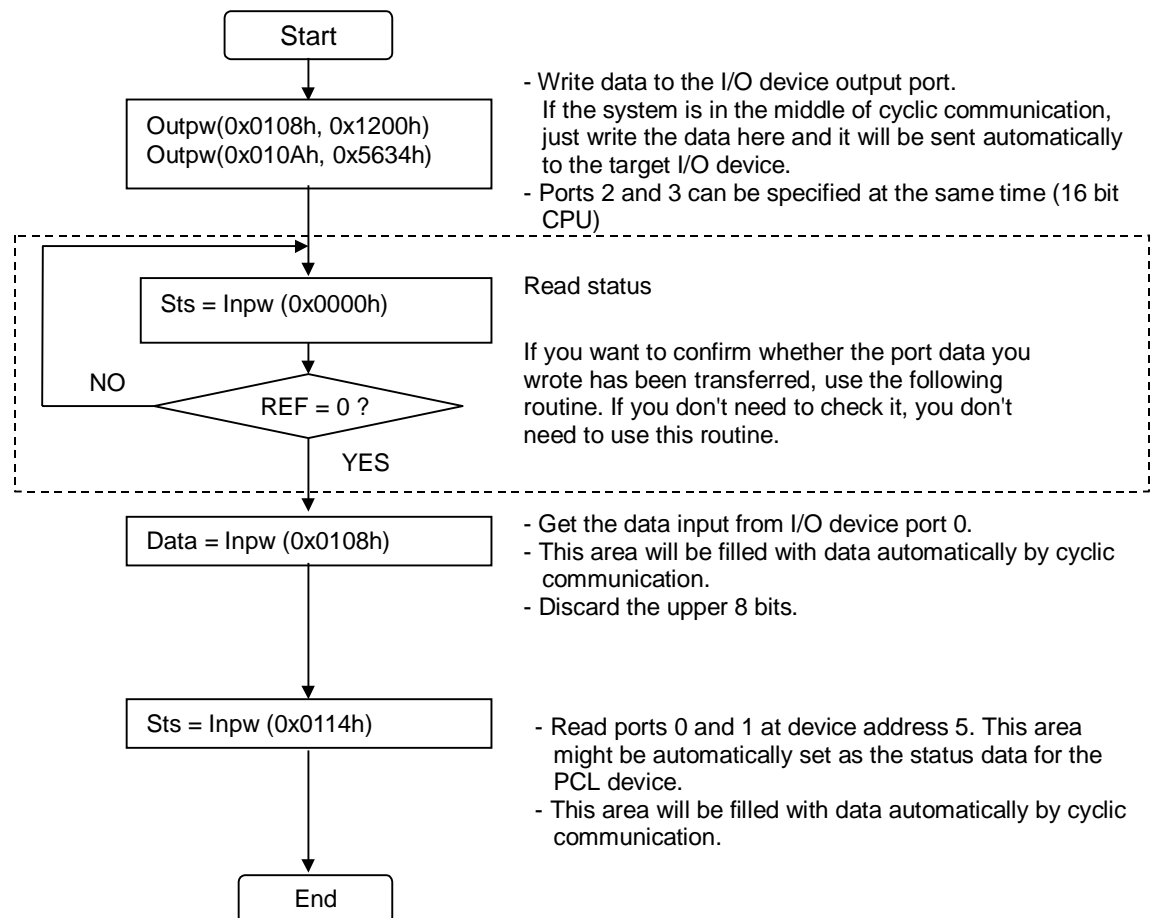

2) When using only the lower 8 bytes in the address map

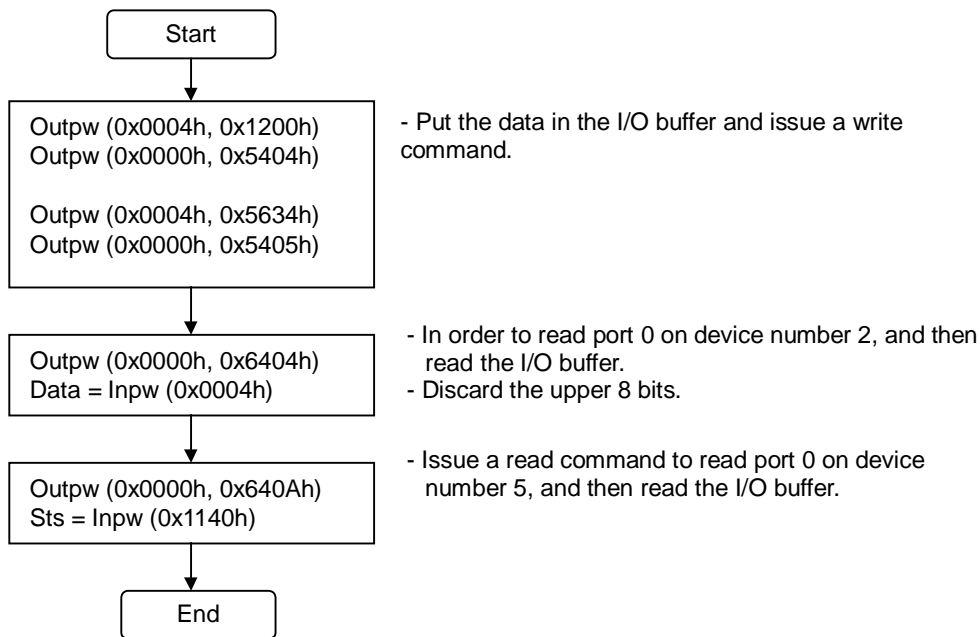

A read command is constructed as follows:

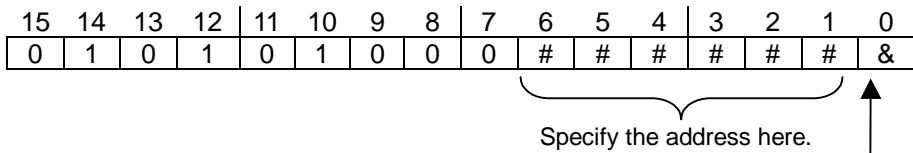

When accessing ports 0 and 1: 0.
When accessing ports 2 and 3: 1.

A write command is constructed as follows:

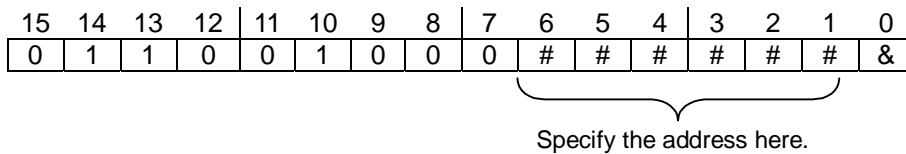

2-7. Data communication 1: Put the value in the register of the PCL device (G9003)

The data communication example below shows data being placed in a register that is integrated in the PCL device (G9003).

Assume that the local devices to be used are as follows.

Assume that "00123456h" will be placed in the "RMV" register of the PCL device.

Device type	Configuration item	Device number
PCL device	Device address	40 (28h)

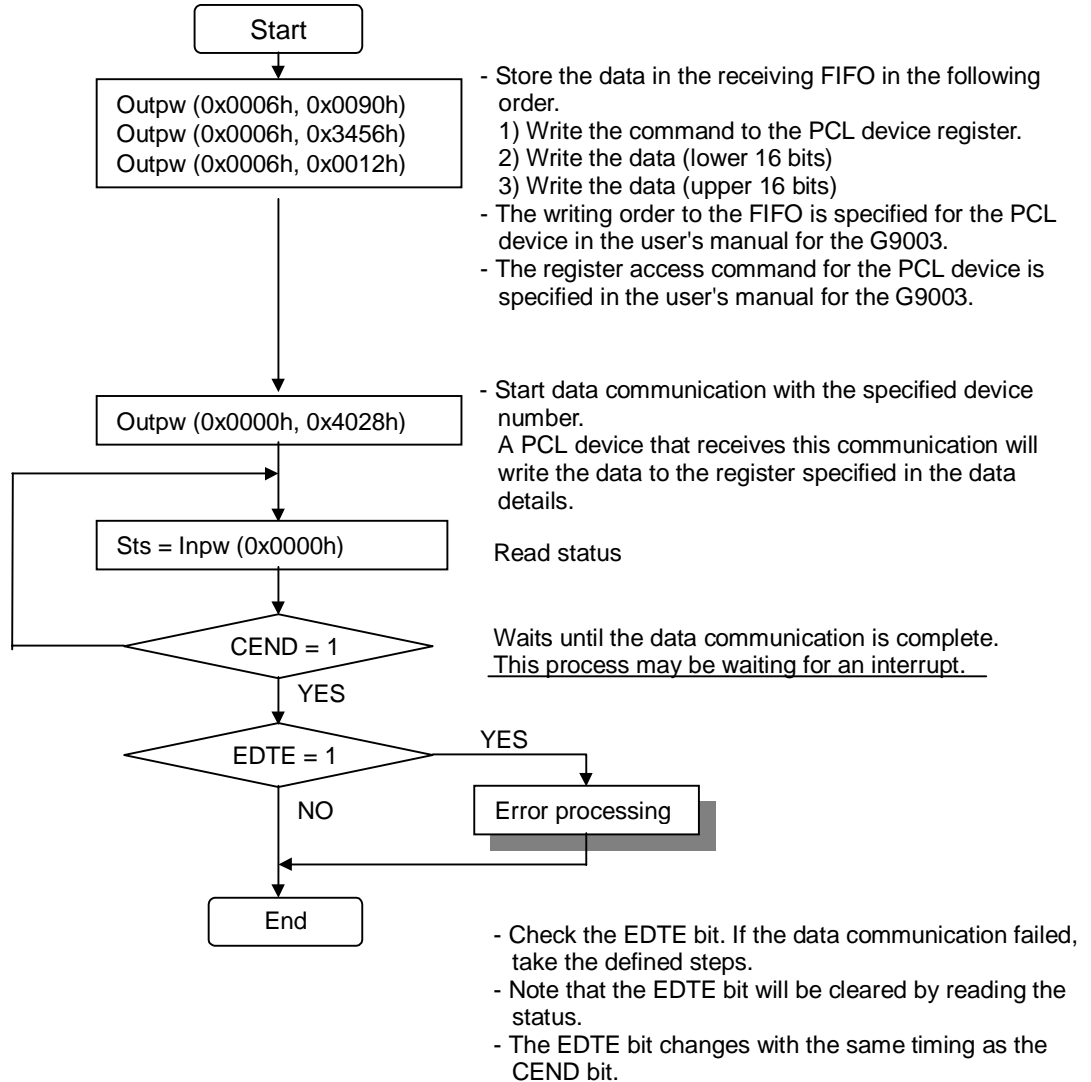

A data communication command is constructed as follows:

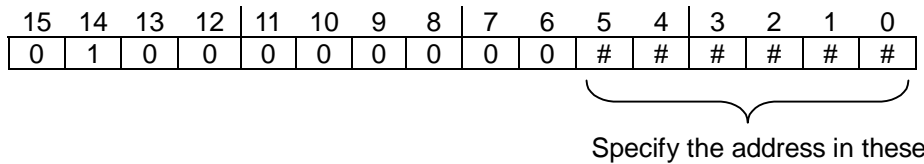

2-8. Data communication 2: Read a register in a PCL device (G9003)

The example of data communication below shows how to read a register that is integrated in the PCL device (G9003).

Assume that the local devices to be used are as follows.

Assume you want to read the register value in the PCL device.

Device type	Configuration item	Configuration data
PCL device	Device address	40 (28h)

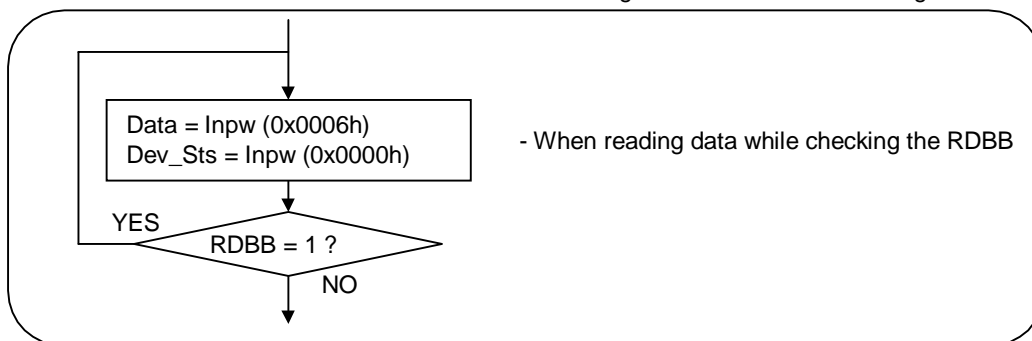
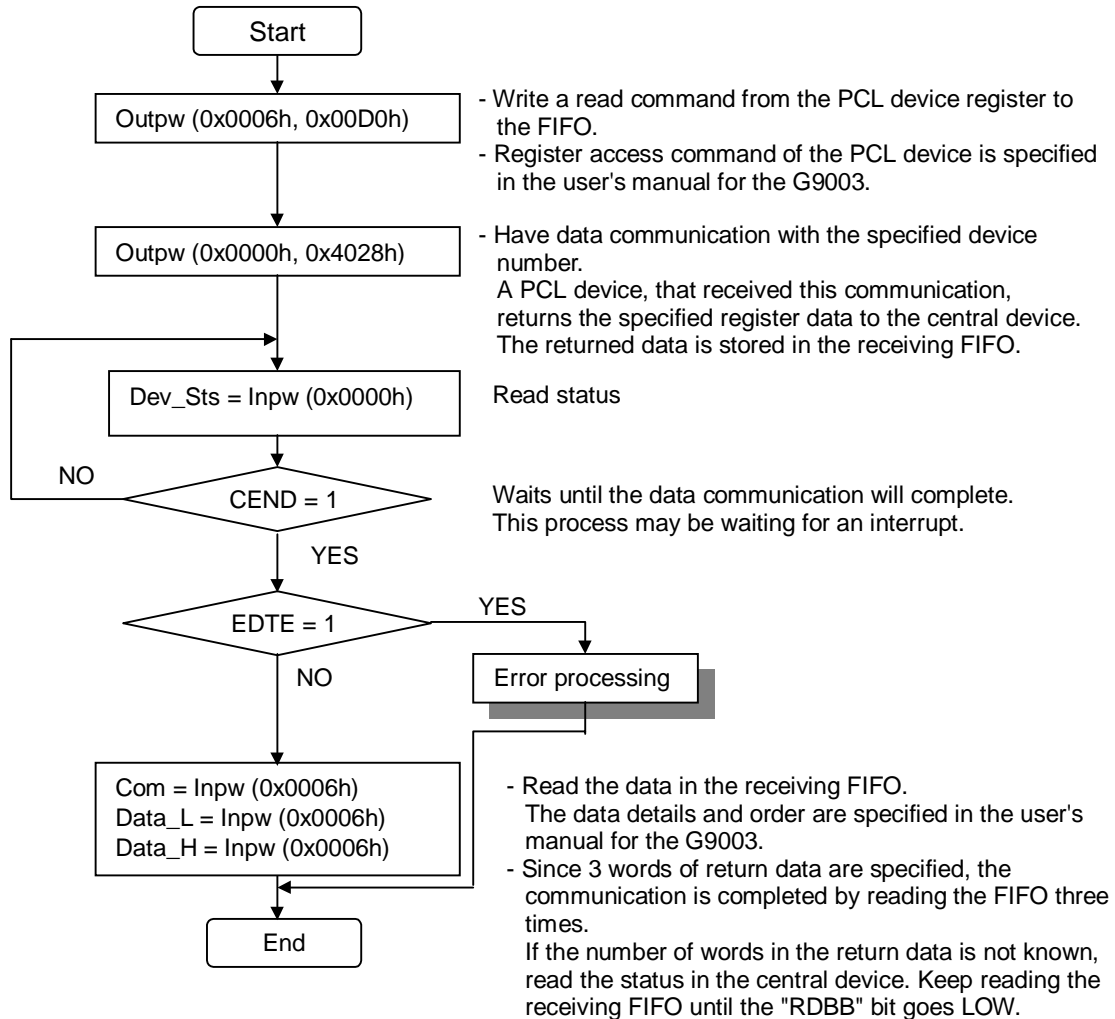

2-9. Data communication 3: Start the PCL device (G9003)

The data communication example below shows how to start pulse output by setting the registers in the PCL device (G9003).

The local devices are the same as in the previous section.

Assume that the data to place in the PCL device are as follows (only the data needed to trigger the pulse output).

Register name	Set value	Remarks
RFL	00000100h	
RFH	00000200h	
RMG	00C7h	Multiplication rate = 1

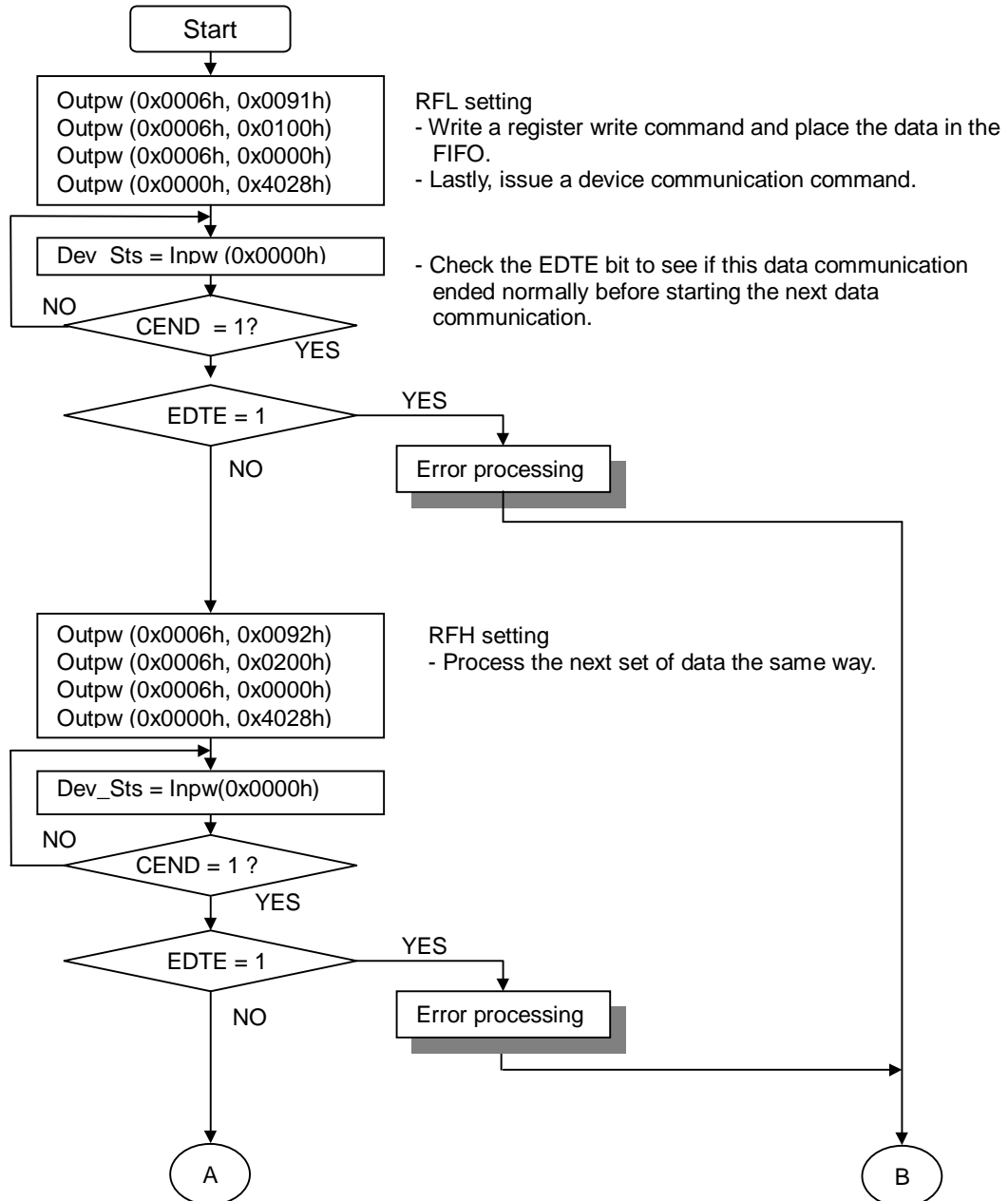

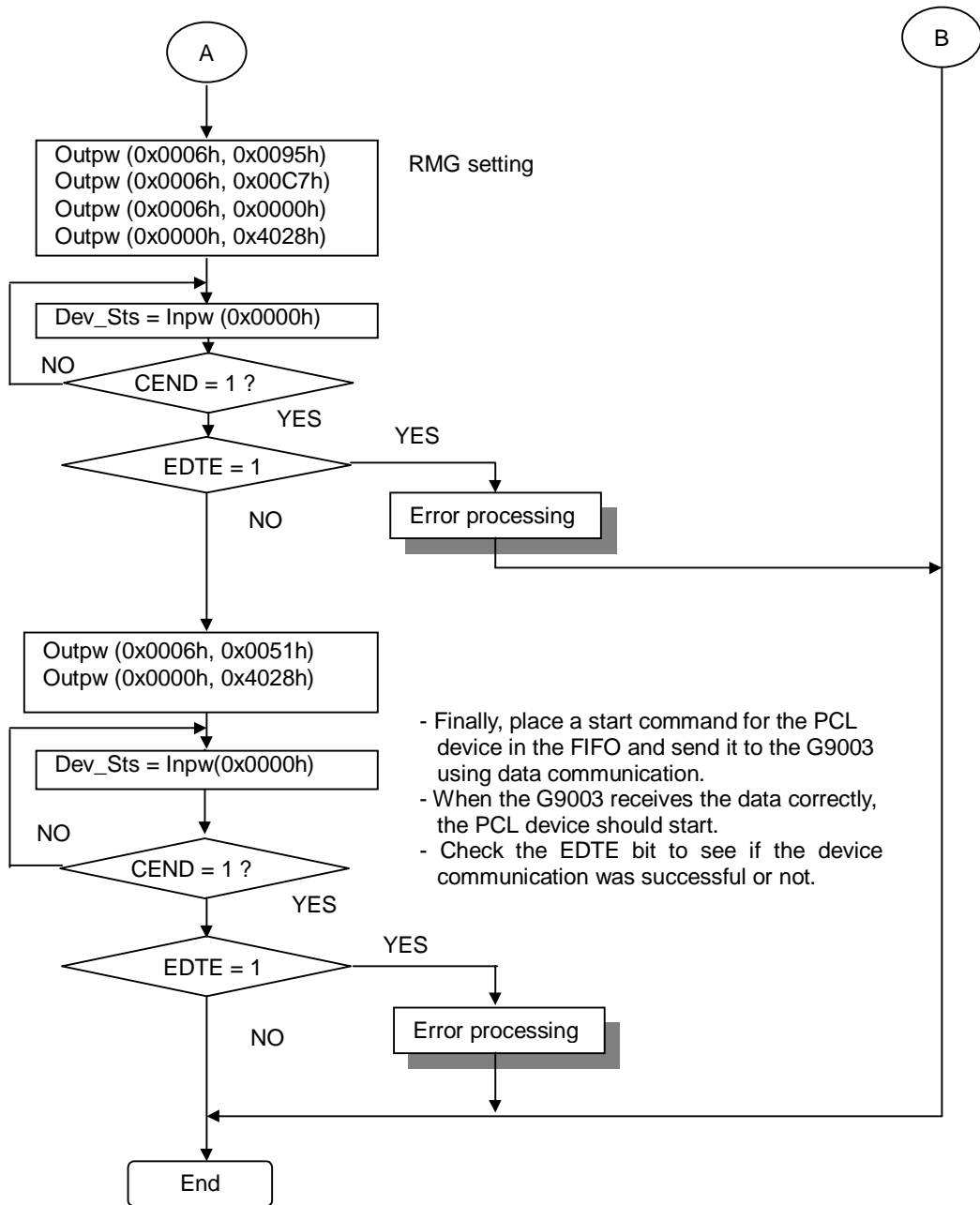

2-10. Data communication 4: Start a PCL6045A/B using a CPU emulation device

The CPU emulation device (a G9004) can substitute for a CPU, and it can be connected to normal CPU peripheral devices. This section gives an example of how to start the PCL6045A/B (LSI made by NPM that is used to generate pulse trains for 4 axes).

Device type	Configuration item	Configuration data
G9004	Device address	40 (28h)

Registers to set in the PCL6045A/B

Register name	Set value	Remark
PRFL	00000100h	
PRFH	00000200h	
PRMG	012Bh	Multiplication rate = 1

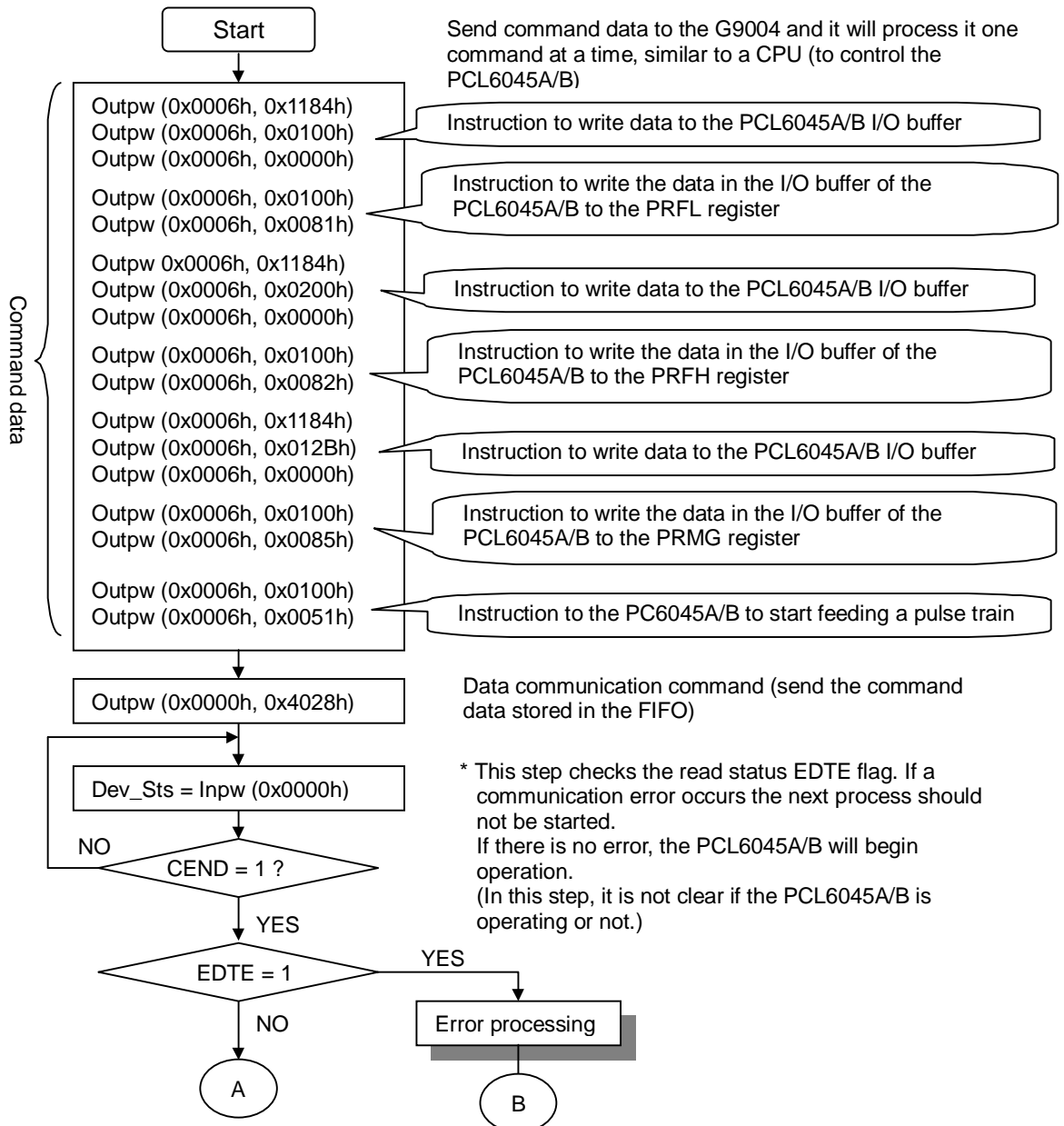

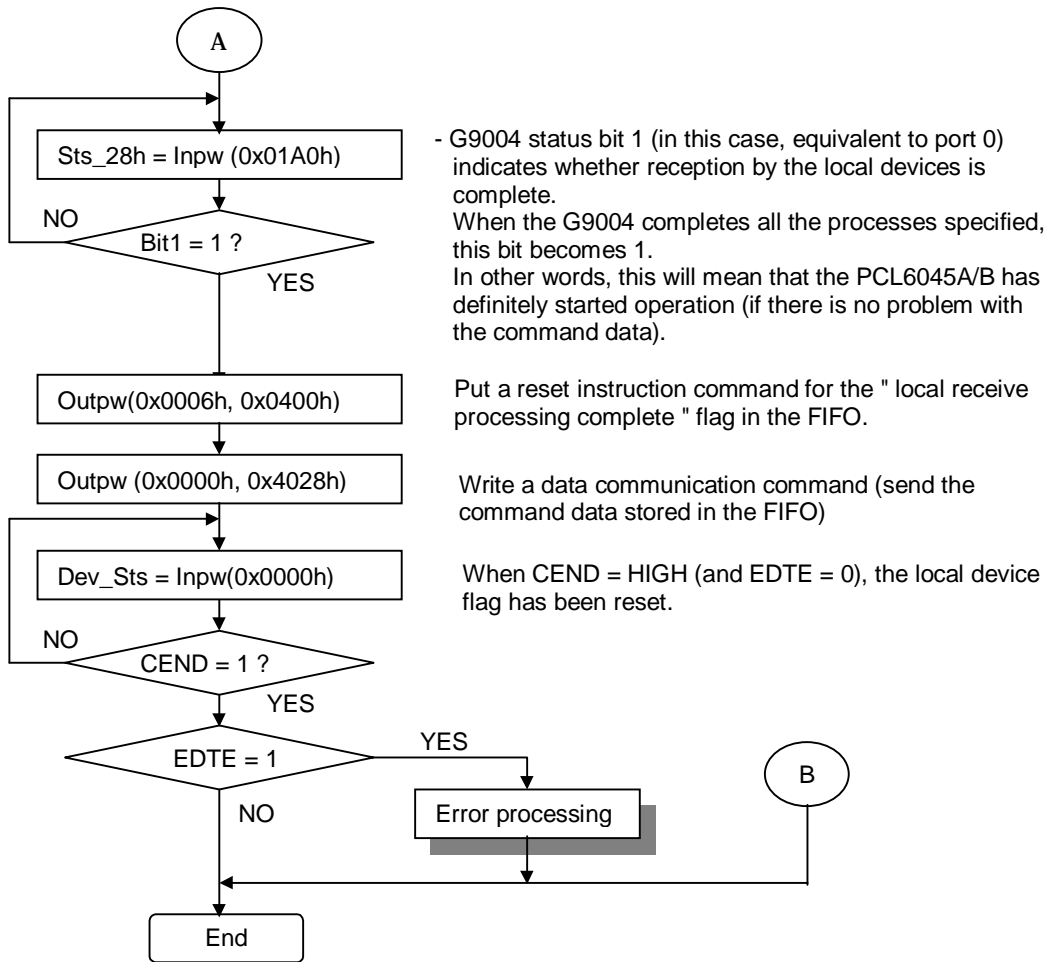

For a detailed description of the G9004 CPU emulation device, see the user's manual. In this paragraph, a simple explanation will be provided following the example above. Assume that the G9004 is substituting for a 16-bit CPU.

* Let the CPU emulation device substitute for a CPU

The description of how to set the external terminals on the CPU emulation device is omitted.

The present subject is how to define the CPU operation to be done.

See the flow chart for writing command data to the FIFO. Make sure the first data written sends "1184h" to the FIFO. This is the operation command for the CPU emulation device. The CPU emulation device interprets the data received as follows.

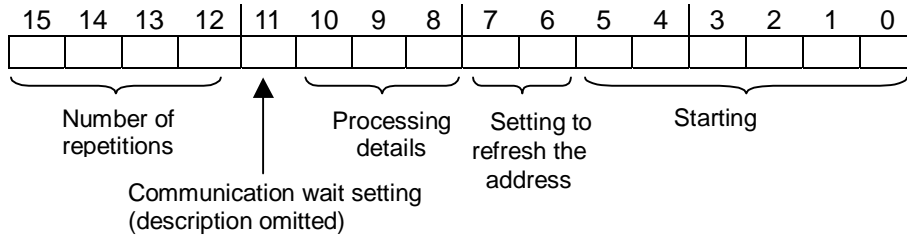

- Starting address

Address to output on the address bus when the CPU emulation device is substituted for a CPU.

When it substitutes for a 16-bit CPU, the lowest bit is ignored (always 0).

- Address modification

When the number of repetitions is set to 1 or more, the CPU emulation device will repeat multiple processes continuously. In this case, specify how to modify the addresses that will be output for each process.

0X: Address is fixed

10: Increment the address (When an 8-bit CPU, +1. When a 16-bit CPU +2.)

11: Decrement the address (When an 8-bit CPU, -1. When a 16-bit CPU -2.)

- Processing details

Specify what the CPU should do.

001: Write

010: Read

The description of other combined processes is omitted.

- Number of repetitions

When 0 is specified, the G9004 will execute the process details one time.

When 1 or more is specified, the G9004 will execute the operation specified in the processing details the number of repetitions +1.

Now, interpret the values placed in the FIFO as follows:

[Interpreted results]

To address 04h,

While incrementing the address number,

Write data,

Two times.

= Write data two times to address 04h while adding one to the address each time.

Then, what data should be written? This corresponds to two words written to the FIFO sequentially. Since the G9004 will execute the process two times, two words need to be written.

In all, the following operations were commanded by the CPU emulation device.

- 1st process: Write 0100h to the specified address (004h).
- 2nd process: Write 0000h to the specified address (006h).

Actually, these operations are equivalent to the procedures used to place data in the I/O buffer of the PCL6045A/B.

After that, instructions are needed about which data should be written to which register. These are equivalent to the following blocks written to the FIFO. Let's look at them.

0100h and 0081h were written to the FIFO.

The first data is sent to the CPU emulation device. The interpreted meanings are as follows.

[Interpreted results] Write data (0081h) to specified address (00h) once.

This instruction is used to issue a command to the PCL6045A/B and has the meaning: write the contents of the I/O buffer into the PRFL register
Now the data are sent to the PRFL.

In the same way, commands can be stacked up in the FIFO, so that the register setting is complete.

The last "0100h" and "0051h" mean: write 0051h to address 00h.

This instruction corresponds to the FH speed start command on the PCL6045A/B. After receiving this instruction, the PCL6045A/B starts feeding pulses at FH speed.

Groups of commands can be stacked up for sending in the FIFO. When a certain number of commands is stored in the FIFO, send the command data to the CPU emulation device using data communication. While interpreting the command data received, the CPU emulation device will repeat its operation as a substitute for a CPU.

When all of the commands have been received, the CPU emulation device turns on a bit in the status data which mean that the local side has completed the reception process. This is passed along to the central device (by cyclic communication).

Notes

Be careful about the size of the command data group sent to the CPU emulation device.

The FIFO in the central device is 256 bytes long. As long as the command group size does not exceed this value, there should not be a problem.

However, if the communication data increases, the ratio of data that need to be caught as communication errors, such as electrical noise, will increase. If the amount of data is small, the data packet size used for sending is also small, and it may be possible to for data packets to pass through between burst of noise. If the packet size is too large, a data collapse may occur due to a noise environment (CRC error), in which case proper communication cannot be established.

If the communication line is too long or the number of local devices connected is too great, it is better to send command data after dividing it into smaller pieces.

2-11. An example of measuring when a break occurs

The central device sends a break frame request periodically (every 16,384 cycles of I/O communication, or every 250ms at 20 Mbps).

At this time, if there is a device that has just been added to the communication line (it places an H on the BRK terminal for a certain interval), the local device will return a break frame.

If the central device receives this break frame, it sets the BRKF bit in the status (STSW) register HIGH and changes the INT signal to LOW. Now, using the interrupt, the CPU can see that a new device has been added.

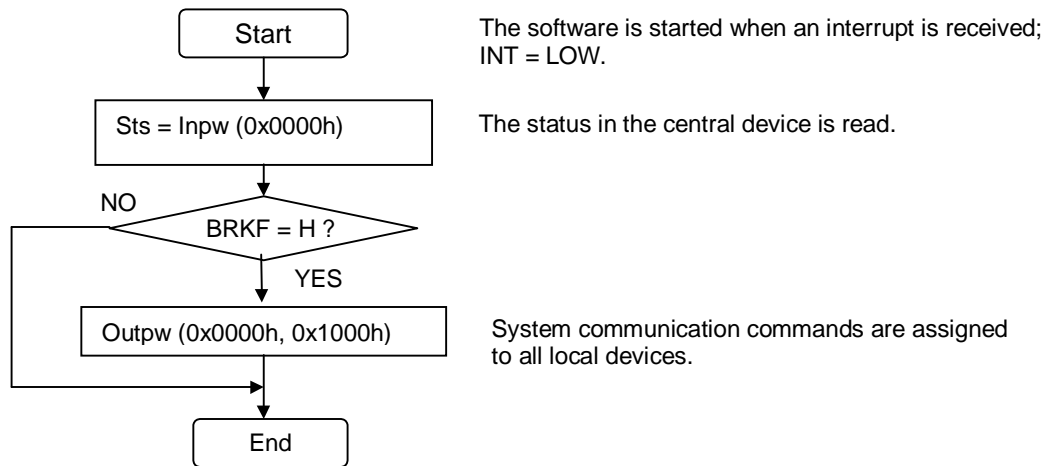

V. Troubleshooting

During the initial design stage, your system may not function normally due to simple misunderstandings, or you may need to think about the problem differently. If your system does not function normally after it is completely designed, check the following:

1. Checking the central device

- 1) Is power supplied properly? (3.3 V only)
- 2) Is the external clock signal stopped while a reset signal is input?
- 3) Is the reset signal released?
- 4) Is the clock signal supplied correctly? (40 MHz or 80 MHz)
- 5) Is the CKSL terminal set correctly? (LOW = 40 MHz, HIGH = 80 MHz)
- 6) Does the IF (1:0) terminal setting match the CPU that is connected?
- 7) Is the data transfer speed identical throughout the system?
- 8) Do the access times follow the specified timings?
- 9) Is there open state input terminal?

2. Checking the local devices

- 1) Is power supplied properly? (3.3 V only)
- 2) Is the external clock signal stopped while a reset signal is input?
- 3) Is the reset signal released?
- 4) Is the clock signal supplied correctly? (40 MHz or 80 MHz)
- 5) Is the CKSL terminal set correctly? (LOW = 40 MHz, HIGH = 80 MHz)
- 6) Does the data transfer speed match the setting on the central device?
- 7) When the DNSM is HIGH, is the address set properly through the DN (5:0) terminal? (The address must be set using negative logic)
- 8) When the DNSM is LOW, are the signals from other local devices through the DNSO terminal connected to the DN0 terminal?
If this signal is held LOW, normal address setting cannot be performed.
- 9) Is one of the DNSO signals connected to the DN0 terminals of multiple local devices?
Connect the DNSO signals in a daisy chain arrangement.
- 10) Is an SOEL signal output by another local device connected to the SOEI terminal?
Only the SOEH signal can be connected to the SOEI terminal.
- 11) When the device being checked is an I/O device, is the PMD (2:0) terminal setting wrong? Is the combination of input and output ports set properly?
- 12) When the device being checked is an I/O device, are the settings on P0N, P1N, P2N, and/or P3N correct? Using these terminals, the signal logic can be changed for each port.
- 13) Is there an open state input terminal?
- 14) After releasing a reset, does the TOUT terminal go LOW? If so, a local device is waiting for a signal from the central device. (The devices themselves must be appropriate.)

3. Checking the system

- 1) Is cable polarity correct?
Twisted pair cables must be used. The polarity of these two lines must be correct. The output from "Y" on the RS485 chip must be connected to input "A" on another RS485 chip, and output "Z" must be connected to input "B".
- 2) Are there termination resistors at both ends of the cable?
- 3) Is a terminal resistor connected in some other position not at the ends?
- 4) When a 5V line transceiver is used, is a level shifter connected?
- 5) Is the inductance of the pulse transformer too low?
- 6) Is the pulse transformer connected properly?
- 7) Are there any faulty contacts on connectors?
- 8) Is the same address used for two local devices?
- 9) Are pulse transformers connected to all branch points?

- 10) If a pulse transformer is not used, is the GND signal connected to all the branch points? (shared GND).
- 11) Is the operating voltage on all the line transceivers at the same level.

VI. Handling Precautions

1. Design precautions

- 1) Never exceed the absolute maximum ratings, even for a very short time.
- 2) Take precautions against the influence of heat in the environment, and keep the temperature around the LSI as cool as possible.
- 3) Please note that ignoring the following may result in latching up and may cause overheating and smoke.
 - Do not apply a voltage greater than +3.3V (greater than 5V for 5V connectable terminals) to the input/output terminals and do not pull them below GND.
 - Please consider the voltage drop timing when turning the power ON/OFF. Consider power voltage drop timing when turning ON/OFF the power.
 - Make sure you consider the input timing when power is applied.
 - Be careful not to introduce external noise into the LSI.
 - Hold the unused input terminals to +3.3 V or GND level.
 - Do not short-circuit the outputs.
 - Protect the LSI from inductive pulses caused by electrical sources that generate large voltage surges, and take appropriate precautions against static electricity.
- 4) Provide external circuit protection components so that overvoltages caused by noise, voltage surges, or static electricity are not fed to the LSI.

2. Precautions for transporting and storing LSIs

- 1) Always handle LSIs carefully and keep them in their packages. Throwing or dropping LSIs may damage them.
- 2) Do not store LSIs in a location exposed to water droplets or direct sunlight.
- 3) Do not store the LSI in a location where corrosive gases are present, or in excessively dusty environments.
- 4) Store the LSIs in an anti-static storage container, and make sure that no physical load is placed on the LSIs.

3. Precautions for mounting

3-1. About the central device (G9001)

(1) Plastic packages absorb moisture easily. Even if they are stored indoors, they will absorb moisture as time passes. Putting the packages in to a solder reflow furnace while they contain moisture may cause cracks in plastic case or deteriorate the bonding between the plastic case and the frame.

The storage warranty period is one year as long as the moisture barrier bags are not opened.

(2) If you are worried about moisture absorption, dry the chip packages thoroughly before reflowing the solder.

Dry the packages for 20 to 36 hours at $125 \pm 5^\circ\text{C}$. The packages should not be dried more than two times.

(3) To heat the entire package for soldering, such as infrared or superheated air reflow, make sure to observe the following conditions and do not reflow more than two times.

- Temperature profile

The temperature profile of an infrared reflow furnace must be within the range shown in the figure below. (The temperatures shown are the temperature at the surface of the plastic package.)

- Maximum temperature

The maximum allowable temperature at the surface of the plastic package is 260°C peak [A profile]. The temperature must not exceed 250°C [A profile] for more than 10 seconds. In order to decrease the heat stress load on the packages, keep the temperature as low as possible and as short as possible, while maintaining the proper conditions for soldering.

Package body temperature $^\circ\text{C}$

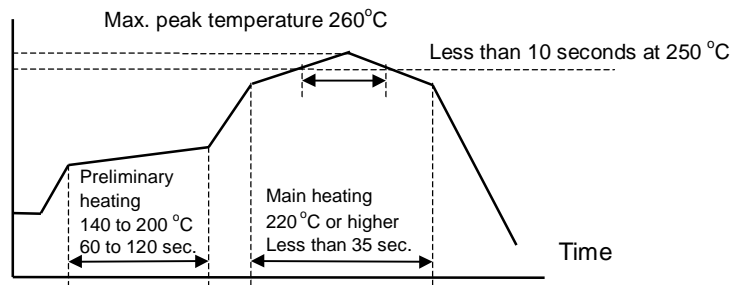

[A profile (applied to lead-free soldering)]

(4) Solder dipping causes rapid temperature changes in the packages and may damage the devices. Therefore, do not use this method.

3-2. I/O device (G9002)

- 1) In order to prevent damage caused by static electricity, pay attention to the following.
 - Make sure to ground all equipment, tools, and jigs that are present at the work site.
 - Ground the work desk surface using a conductive mat or similar apparatus (with an appropriate resistance factor). However, do not allow work on a metal surface, which can cause a rapid change in the electrical charge on the LSI (if the charged LSI touches the surface directly) due to extremely low resistance.
 - When picking up an LSI using a vacuum device, provide anti-static protection using a conductive rubber pick up tip. Anything which contacts the leads should have as high a resistance as possible.
 - When using a pincer that may make contact with the LSI terminals, use an anti-static model. Do not use a metal pincer, if possible.
 - Store unused LSIs in a PC board storage box that is protected against static electricity, and make sure there is adequate clearance between the LSIs. Never directly stack them on each other, as it may cause friction that can develop an electrical charge.
- 2) Operators must wear wrist straps which are grounded through approximately 1M-ohm of resistance.
- 3) Use low voltage soldering devices and make sure the tips are grounded.
- 4) Do not store or use LSIs, or a container filled with LSIs, near high-voltage electrical fields, such those produced by a CRT.
- 5) To preheat LSIs for soldering, we recommend keeping them at a high temperature in a completely dry environment, i.e. 125°C for 24 hours. The LSI must not be exposed to heat more than 2 times.
- 6) When using an infrared reflow system to apply solder, we recommend the use of a far-infrared pre-heater and mid-infrared reflow devices, in order to ease the thermal stress on the LSIs.

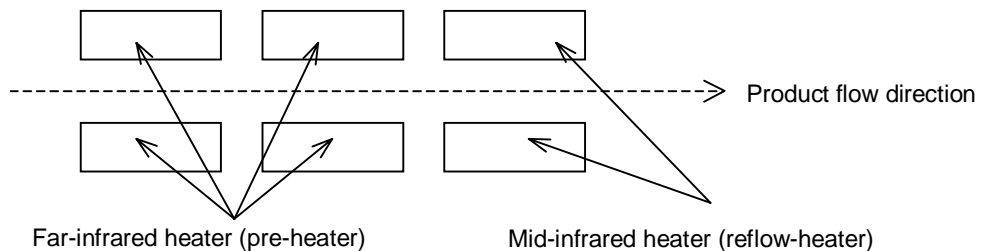

Package and substrate surface temperatures must never exceed 260°C and 230°C for 30 to 50 seconds.

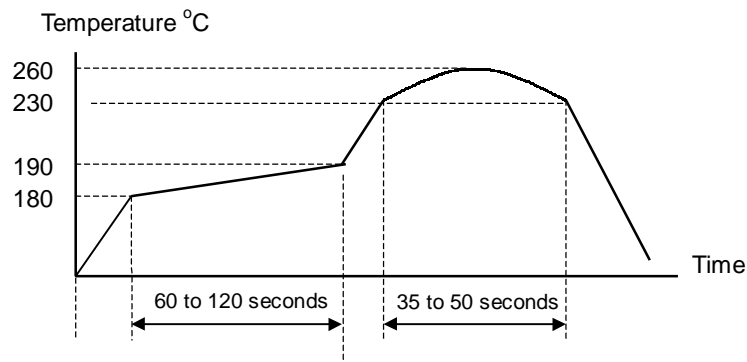

[Recommended temperature profile of a far-infrared heater, hot air reflow]

- (7) When using hot air for solder reflow, the restrictions are the same as for infrared reflow equipment.
- (8) If you will use a soldering iron, the temperature at the leads must not be 260°C or less for more than 10 seconds, and must not be 350°C or less for more than 3 seconds.

4. Other precautions

- 1) When the LSI will be used in poor environments (high humidity, corrosive gases, or excessive amounts of dust), we recommend applying a moisture prevention coating.
- 2) The package resin is made of fire-retardant material; however, it can burn. When baked or burned, it may generate gases or fire. Do not use it near ignition sources or flammable objects.
- 3) This LSI is designed for use in commercial apparatus (office machines, communication equipment, measuring equipment, and household appliances). If you use it in any device that may require high quality and reliability, or where faults or malfunctions may directly affect human survival or injure humans, such as in nuclear power control devices, aviation devices or spacecraft, traffic signals, fire control, or various types of safety devices, we will not be liable for any problem that occurs, even if it was directly caused by the LSI. Customers must provide their own safety measures to ensure appropriate performance in all circumstances.

Notes

NPM NIPPON PULSE MOTOR CO., LTD.

Tokyo Office: No. 16-13, 2-chome, Hongo, Bunkyo-ku, Tokyo 113-0033, Japan
Phone: 81-3-3813-8841 Fax: 81-3-3813-7049

E-mail: device@npm.co.jp <http://www.pulsemotor.com>

NIPPON PULSE AMERICA, INC.: 1073 East Main Street, Radford, VA 24141, U.S.A.

Phone: 1-540-633-1677 Fax: 1-540-633-1674

E-mail: info@nipponpulse.com <http://www.nipponpulse.com>

MNAL. No. G9001/G9002 1A-5203-0.2 (5203) ims
Printed in Japan