

4-Axes Motion Control Card

NPMC6045A-4104

User's Manual (Ver2.1)

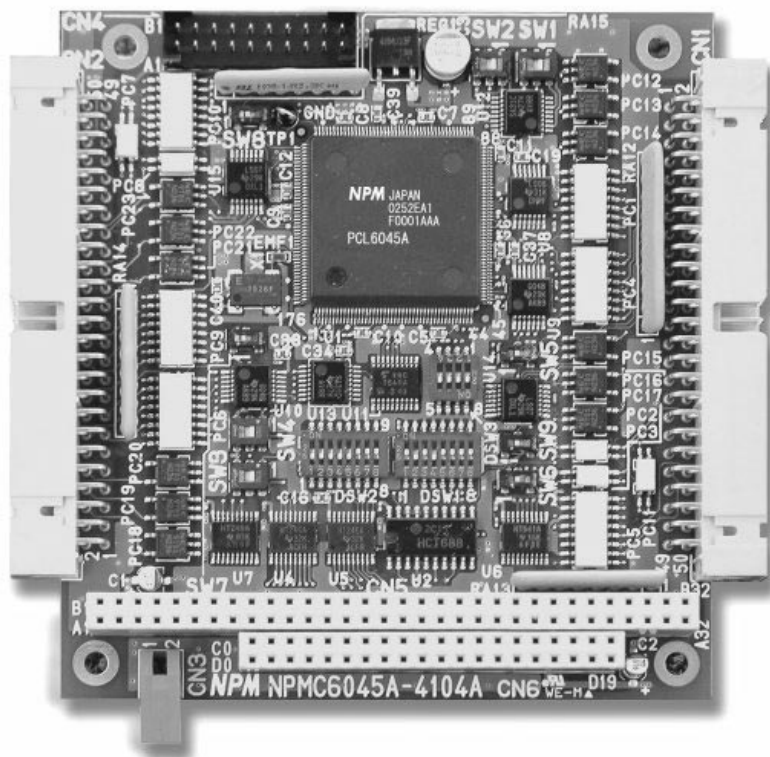

Contents

1. General	1
2. Main Features	1
3. Specifications	2
4. Block Diagram	3
4-1. Whole Block Diagram	3
4-2. #1-4 axis I/F Block Diagram	4
4-2. EMG I/F Block Diagram	5
5. Control Interface	6
5-1. Command Pulse Output:	6
5-2. Encoder Input :	7
5-3. Mechanical Sensors Input:	8
5-4. Emergency Stop Input:	9
5-5. Multipurpose or Digital Servo Input:	9
5-6. Multipurpose or Digital Servo Output:	10
5-7. Simultaneous Start and Stop In/Output:	11
5-8. Manual Pulser or Enable/Disable input:	11
5-9. Others	12
6. Connector Information	13
6-1. CN1: #1 and #2 axis signal	13
6-2. CN2: #3 and #4 axis signal	14
6-3. CN3: Emergency Stop Input	15
6-4. CN4: Manual Pulser , Simultaneous Start and Stop	15
6-5. Type of Connector	15
7. Address	16
7-1. Base Address	16
7-2. Address Map	16
8. Interrupt Request	17
9. Bus Timing	18
9-1. Read Cycle	18
9-2. Write Cycle	19
10. Dimension	20
11. Connection Example	21
11-1. Command pulse Output:	21
11-2. Encoder input:	23
11-3. Multipurpose or Digital Servo Input:	24
11-4. Multipurpose or Digital Servo Output:	24
11-5. Emergency Stop Input:	25
11-6. Mechanical Sensor Input:	25
11-7. Simultaneous Start and Stop In/Output:	26
11-8. Manual Pulser or Enable/Disable Input:	27
12. Position of Switch	28
13. Accessories	28

1. General

NPMC6045A-4104 is an advanced PC/104, 4-axes motion control card that allows control of stepper motors or digital servomotors. The NPMC6045A-4104 incorporates a PCL6045A motion control chip as part of its compact design, and it comes with a C language library.

2. Main Features

- 4-axes control of stepper motors or digital servomotors
- Maximum Command pulse output frequency of 6.5Mpps
- Trapezoidal and constant speed motion profiles
- Linear or S-curve acceleration and deceleration
- Any 2 axes circular interpolation
- 2 to 4 axes linear interpolation
- 28-bit up/down counter for incremental encoder feedback
- Open-collector or Line-driver of encoder inputs available
- Various modes for homing
- Speed and Position change on the fly

Note:

- This board has most functions of the PCL6045A with it. However, the following functions have been removed.
 - Direct Input from Drive Switch (+DRx-u, -DRx-u)
 - General-purpose I/O pins (P3x-u, P4x-u, P5x-u, P6x-u, P7x-u)
 - Counter reset input signal (CLRx-u)
 - Counter latch input signal (LTCx-u)
 - Output signal when the chip is generating pulses (BSYx-u)
- This User's manual has not described the functional details of the PCL6045A. Please refer to the "PCL6045A USER'S MANUAL" regarding the function of PCL6045A, or the details of a register.

3. Specifications

- PC/104 Bus Line: 16 Bit Data Bus
- Occupancy IO Address: 32 Bytes
- IRQ3,4,5,6,9 (Select by switch)
- Pulse Range: +/-134,217,728 (28 bit)
- Ramping-down Pulse Range: 0 to 16,777,215 (24 bit)
- Pulse Rate Registers: FL, FH, FA
- Command Pulse Output Frequency for motor-control: 6.5Mpps (Max Speed)
- Pulse Rate Multiplication Factors: 0.1x to 100x
- Pulse Rate Setting Steps: 1 to 65,535
- Acceleration/Deceleration Rate Setting Range: 1 to 65,535
- Encoder Input: 5MHz (at 90-deg. Phase difference input)
- Multipurpose or Digital Servo Input: MPIN*1, ALM*, and INP* per axis
- Multipurpose or Digital Servo Output: MPOUT*1, MPOUT*2, and ERC* per axis
- Mechanical Sensor Input: PEL*, MEL*, SD*/PCS*, and ORG* per axis
- Emergency Stop Input: EMG
- Simultaneous Start and Stop In/Output: CSTA,CSTP
- Manual Pulsar or Enable/Disable Input: PA*, PB*, and PE* per axis
- Reference Clock for PCL6045A: 19.6608MHz
- Power: DC+5V +/-5%, 400mA (Typ.)
- External Power Input: DC+24V +/-10%, 250mA (Max.)
- Environmental Conditions
 - Temperature: 0 to 40 deg. C
 - Humidity: 80% R.H. maximum

4. Block Diagram

4-1. Whole Block Diagram

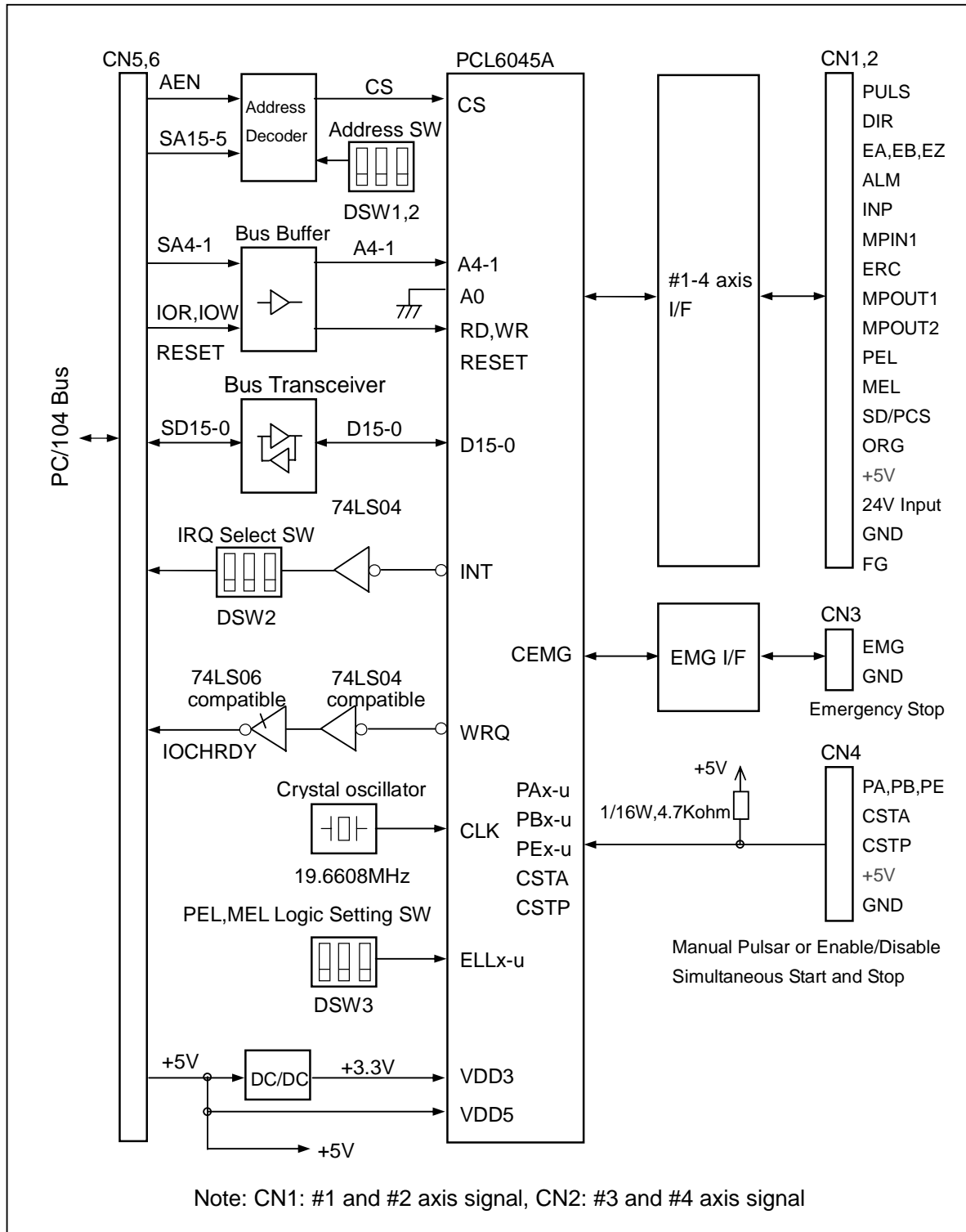

4-2. #1-4 axis I/F Block Diagram

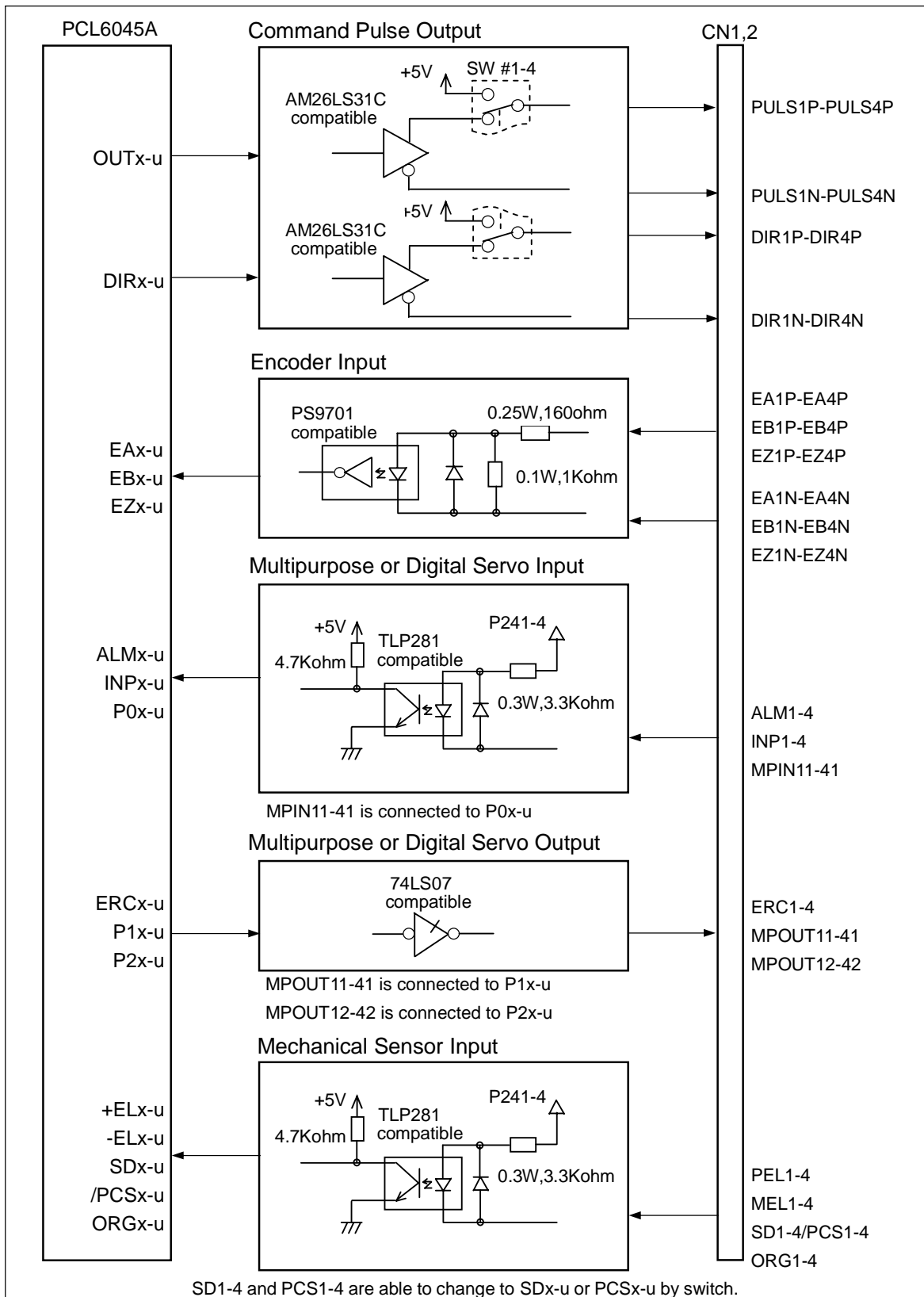

4-2. EMG I/F Block Diagram

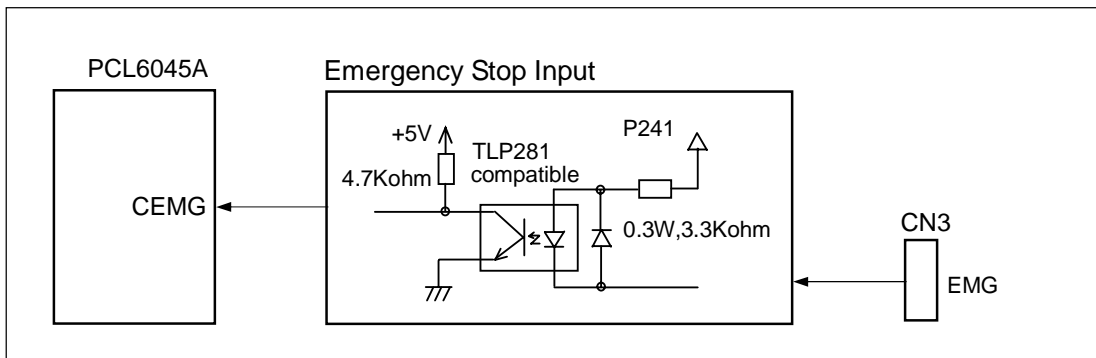

5. Control Interface

5-1. Command pulse Output:

PULS*P, PULS*N, DIR*P and DIR*N

- PULS*P and DIR*P are able to change to +5V output by a switch.
- Two terminals of PLS*P and DIR*P are linked by the switch setting.
 - Side 1-2 and 4-5: Output signal (right phase of line driver)
 - Side 2-3 and 5-6: Output +5V
- Logic
 - For the signal of positive logic, RENV1 (Register of PCL6045A) must be set.
Bit Name RMD2-0 as follows:
 - In the case of CW and CCW output: RMD2-0 set "100"
 - In the case of Pulse and Direction: RMD2-0 set "000"
- Interface
 - PULS*P and DIR*P are right phase of Line driver.
PULS*N and DIR*N are reverse phase of Line driver.
 - Output specification
 - High level output current: IOH=-20mA max.
 - Low level output current: IOL=20mA max.
 - High level output voltage: 2.5V min. (at Vcc=4.75V,IOH=-20mA)
 - Low level output voltage: 0.5V max. (at Vcc=4.75V,IOL=20mA)

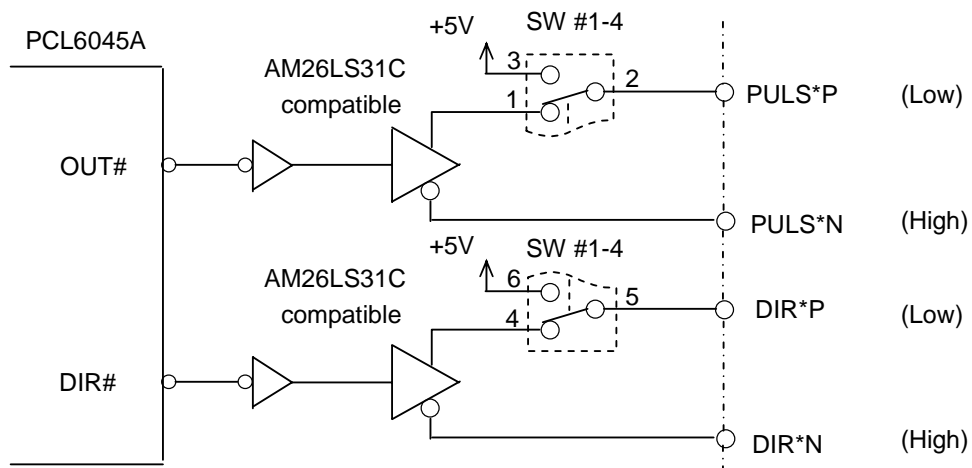

SW #1-4

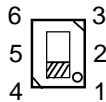

The inside of () is the output logic when making the input of AM26LS31C into Low level.

Case in the picture of above (line driver)

5-2. Encoder Input:**EA*P, EA*N, EB*P, EB*N, EZ*P and EZ*N**

- Logic
 - When the optoisolator is ON, active Hi
- Filter for input
 - If you need, the digital noise filter for about 150nsec can be attached.
 - Method
 - RENV1 (Register of PCL6045A), Bit Name EINF set "1".
- Interface
 - This line is connectable with the line driver output (compatible for AM26LS32AC) of an encoder, an open collector output, and an optoisolator output. Moreover, a line driver output can be connected, without attaching outside restriction resistor.
 - Speed response: 5.0MHz max. (at $I_f = 7.5\text{mA}$, 90-deg. phase difference input and no noise filter)

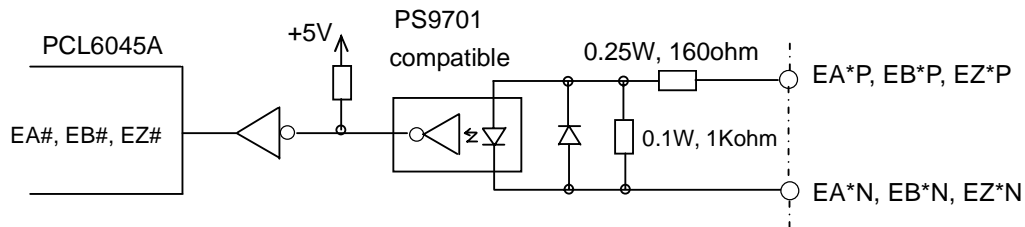

5-3. Mechanical Sensors Input:

PEL*/MEL* (+/-Limit), ORG* (Home), and SD* (Ramping-down)/PCS* (target position override)

- P241 to P244 need the power supply of +24Vdc.
- Be able to change the setting to SD or PCS

SD# : 1-2
 PCS# : 2-3

SW #5-8

Interior circuit of a switch

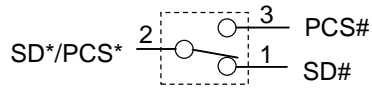

• Logic

- ORG* , SD*/PCS* : How to receive as '1' at the time of an optoisolator ON .
 - ORG* : RENV1 (Register of PCL6045A) , bit name ORGL set "0" . (Negative).
 - SD* : RENV1 (Register of PCL6045A) , bit name SDL set "0" . (Negative).
 - PCS* : RENV1 (Register of PCL6045A) , bit name PCSL set "0" . (Negative).
- PEL* , MEL* : Logic change is possible by the switch.
 - Switch ON: Optoisolator ON, and then end-limit signal OFF.
 - Switch OFF: Optoisolator ON, and then end-limit ON.

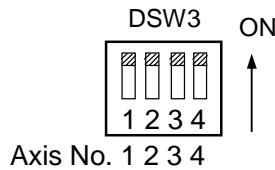

• Filter for input

- PEL* , MEL* , ORG* , SD* : If you need, the digital noise filter for about 4μsec can be attached.
 - Method
 RENV1 (Register of PCL6045A) , bit name FLTR set "1".

• Interface:

- Input current If = 6.9mA TYP. (at P241-4 = 24V)

PEL* , MEL* , ORG*

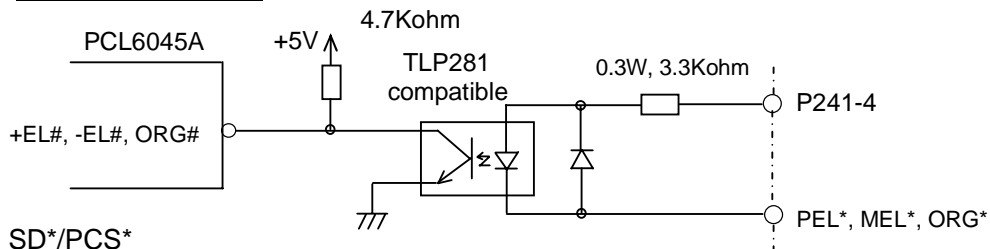

SD*/PCS*

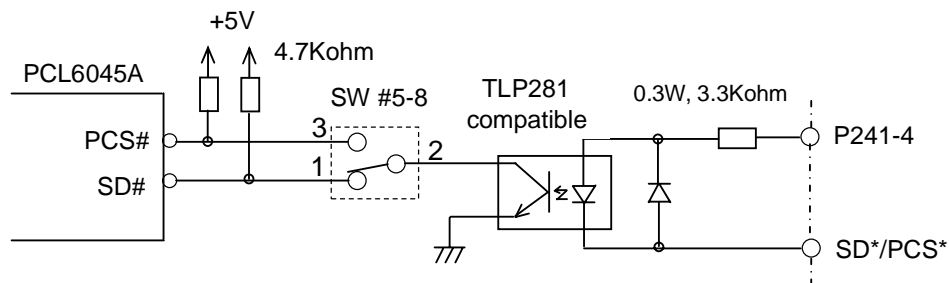

5-4. Emergency Stop Input:

EMG

- P241 need the power supply of +24Vdc.
- Logic
 - When the EMG is enabling, the optoisolator is ON and then EMG is OFF.
- Possible select enable or disable of the emergency by SW9.

Enable: 1-2
Disable: 2-3

SW #9

Interior circuit of a switch

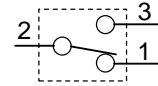

- Interface:
 - Input current $I_f = 6.9\text{mA TYP. (at P241 = 24V)}$

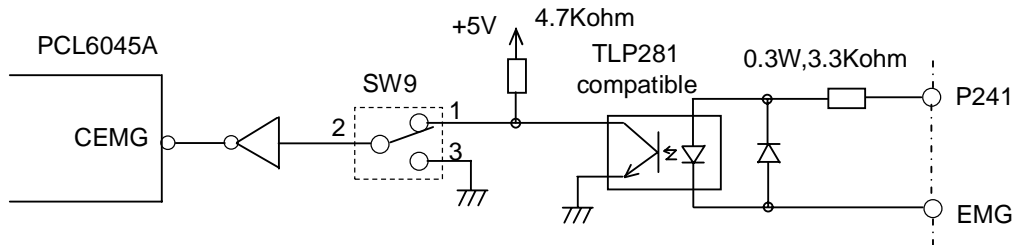

5-5. Multipurpose or Digital Servo Input:

MPIN*1(Multipurpose Input), ALM*(Alarm) and INP*(In-position)

- MPIN*1 is the multipurpose input. This signal is connected to the general-purpose I/O pin P0# of PCL6045A.
- These terminals can be used for digital servo driver interface.
- Terminals of P241-4 are external input from power supply +24Vdc.
- Input Setting
 - General-purpose I/O pin P0# set Input.
 - Method
RENV2 (Register of PCL6045A) , bit name P0M1-0 set "00".
- Logic
 - ALM* , INP* : How to receive as '1' at the time of an optoisolator ON .
 - ALM* : RENV1 (Register of PCL6045A) , bit name ALML set "0" . (Negative)
 - INP* : RENV1 (Register of PCL6045A) , bit name INPL set "0" . (Negative)
 - MPIN*1 : Optoisolator is ON, and then active L . (Negative)
- Filter for input
 - ALM* , INP* : If you need, the digital noise filter for about 4μsec can be attached.
 - Method
RENV1 (Register of PCL6045A) , bit name FLTR set "1".
- Interface:
 - Input current $I_f = 6.9\text{mA TYP. (at P241-4 = 24V)}$

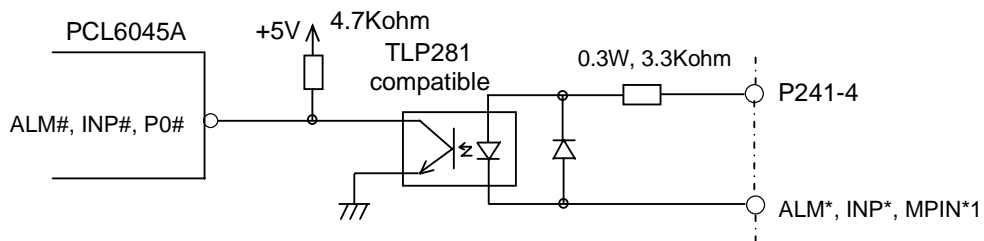

5-6. Multipurpose or Digital Servo Output:**MPOUT*1(Multipurpose output #1 or Enable for Motor), MPOUT*2 (Multipurpose Output #2 or Alarm Reset) and ERC* (Reset the Encoder Counter)**

- These terminals are mainly for the digital servo interface.
- MPOUT*1 and MPOUT*2 are able to use multipurpose output.
MPOUT*1 is connected to the general-purpose I/O pin P1# of PCL6045A.
MPOUT*2 is connected to P2# of it.
- Output Setting
 - General-purpose I/O pin P1# P2# set Output.
 - Method
 - P1# : RENV2 (Register of PCL6045A), bit name P1M1-0 set "01".
 - P2# : RENV2 (Register of PCL6045A), bit name P2M1-0 set "01".
- Logic:
 - ERC* : How to set up '1' and use as the output transistor ON.
 - RENV1 (Register of PCL6045A) , Bit Name ERCL set "0" . (Negative)
 - MPOUT*1 and 2 : If '0' is set as P1# P2#, it will become the output transistor ON . (Negative)
 - Note :
The general-purpose output should write in and use "1" for the corresponding bit before setting the RENV2 as an output.
Since an output transistor will be set to ON, when configuration is carried out, if the bit continues being 0, cautions are required.
- Interface:
 - Rated output voltage: 30V max.
 - Output current: $I_{OL}=48\text{mA}$ max.
 - Low level output voltage: $V_{OL}=0.5\text{V}$ max. (at $V_{CC}=4.75\text{V}$, $I_{OL}=48\text{mA}$)

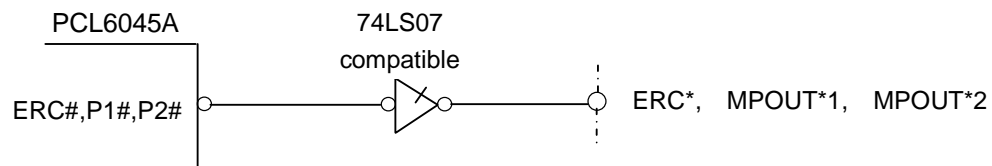

5-7. Simultaneous Start and Stop In/Output:

CSTA and CSTP

- These terminals are use for the simultaneous start and stop when you use other NPMC6045A-boards on the same PC/104 bus.

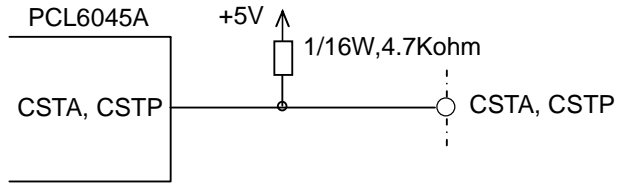

5-8. Manual Pulsar or Enable/Disable input:

PA*, PB* and PE*

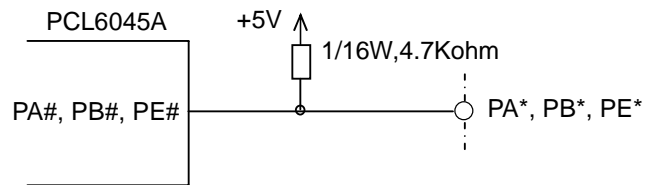

5-9. Others

- General-purpose I/O pins (P3x-u, P4x-u, P5x-u, P6x-u, and P7x-u) of PCL6045A.
 The P3-7 is not using this board. The pull-up of this signal is carried out to +5V by 4.7Kohm inside this board.
 Therefore, please setup the RENV2 register as general-purpose input '00'.
 Moreover, this input of P3-7 is always '1'.

Pin Name	Bit Name	Setup	Logic by PCL6045A
P0# (MPIN*1)	P0M1-0	general-purpose input	00 active L (negative)
P1# (MPOUT*1)	P1M1-0	general-purpose output	01 active L (negative)
P2# (MPOUT*2)	P2M1-0	general-purpose output	01 active L (negative)
P3#	P3M1-0	general-purpose input	00 always '1'
P4#	P4M1-0	general-purpose input	00 always '1'
P5#	P5M1-0	general-purpose input	00 always '1'
P6#	P6M1-0	general-purpose input	00 always '1'
P7#	P7M1-0	general-purpose input	00 always '1'

- The power supply for an external input, terminals of P241-4
 These signals are the object for the input of each axis. It is the common terminal which supplies power supply +24Vdc .
 P241
 #1-axis input (ALM1, INP1, MPIN11, PEL1, MEL1, SD1/PCS1, ORG1) and (EMG)
 P242-4
 #2-4-axis input (ALM2-4, INP2-4, MPIN21-41, PEL2-4, MEL2-4, SD2-4/PCS2-4, ORG2-4)

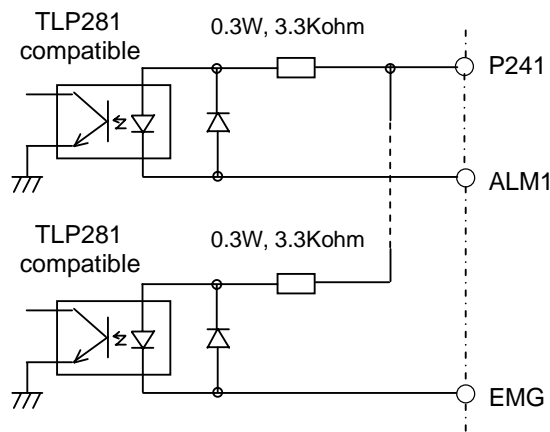

6. Connector Information

6-1. CN1: #1 and #2 axis signal

Stepper Driver, Digital Servo Driver, Encoder, and Mechanical Interface

	#	Pin Name	I/O	#	Pin Name	I/O
#1-axis Command pulse	1	PULS1P	O	2	PULS1N	O
	3	DIR1P	O	4	DIR1N	O
Encoder	5	EA1P	I	6	EA1N	I
	7	EB1P	I	8	EB1N	I
	9	EZ1P	I	10	EZ1N	I
Power	11	+5V	O	12	GND	
Multipurpose or Digital-Servo	13	MPIN11	I	14	ALM1	I
	15	INP1	I	16	ERC1	O
	17	MPOUT11	O	18	MPOUT12	O
Mechanical Sensor	19	PEL1	I	20	NEL1	I
	21	SD1/PCS1	I	22	ORG1	I
#2-axis Command pulse	23	PULS2P	O	24	PULS2N	O
	25	DIR2P	O	26	DIR2N	O
Encoder	27	EA2P	I	28	EA2N	I
	29	EB2P	I	30	EB2N	I
	31	EZ2P	I	32	EZ2N	I
Power	33	+5V	O	34	GND	
Multipurpose or Digital-Servo	35	MPIN21	I	36	ALM2	I
	37	INP2	I	38	ERC2	O
	39	MPOUT21	O	40	MPOUT22	O
Mechanical Sensor	41	PEL2	I	42	MEL2	I
	43	SD2/PCS2	I	44	ORG2	I
Power	45	P241(+24V INPUT)	I	46	P242(+24V INPUT)	I
	47	+5V	O	48	GND	
	49	GND		50	FG (Frame Ground)	

6-2. CN2: #3 and #4 axis signal**Stepper Driver, Digital Servo Driver, Encoder, and Mechanical Interface**

	#	Pin Name	I/O	#	Pin Name	I/O
#3-axis Command pulse	1	PULS3P	O	2	PULS3N	O
	3	DIR3P	O	4	DIR3N	O
Encoder	5	EA3P	I	6	EA3N	I
	7	EB3P	I	8	EB3N	I
	9	EZ3P	I	10	EZ3N	I
Power	11	+5V	O	12	GND	
Multipurpose or Digital-Servo	13	MPIN31	I	14	ALM3	I
	15	INP3	I	16	ERC3	O
	17	MPOUT31	O	18	MPOUT32	O
Mechanical Sensor	19	PEL3	I	20	NEL3	I
	21	SD3/PCS3	I	22	ORG3	I
#4-axis Command pulse	23	PULS4P	O	24	PULS4N	O
	25	DIR4P	O	26	DIR4N	O
Encoder	27	EA4P	I	28	EA4N	I
	29	EB4P	I	30	EB4N	I
	31	EZ4P	I	32	EZ4N	I
Power	33	+5V	O	34	GND	
Multipurpose or Digital-Servo	35	MPIN41	I	36	ALM4	I
	37	INP4	I	38	ERC4	O
	39	MPOUT41	O	40	MPOUT42	O
Mechanical Sensor	41	PEL4	I	42	MEL4	I
	43	SD4/PCS4	I	44	ORG4	I
Power	45	P243(+24V INPUT)	I	46	P244(+24V INPUT)	I
	47	+5V	O	48	GND	
	49	GND		50	FG (Frame Ground)	

6-3. CN3: Emergency Stop Input

No.	Signal Name	Description
1	EMG	Emergency Stop Input
2	GND	GND

6-4. CN4: Manual Pulsar , Simultaneous Start and Stop

No.	Signal Name	Description
A1	PA1	External A-phase Pulse inputs to #1-axis
B1	PB1	External B-phase Pulse inputs to #1-axis
A2	PE1	Enable for External Pulse of #1-axis
B2	PA2	External A-phase Pulse inputs to #2-axis
A3	PB2	External B-phase Pulse inputs to #2-axis
B3	PE2	Enable for External Pulse of #2-axis
A4	PA3	External A-phase Pulse inputs to #3-axis
B4	PB3	External B-phase Pulse inputs to #3-axis
A5	PE3	Enable for External Pulse of #3-axis
B5	PA4	External A-phase Pulse inputs to #4-axis
A6	PB4	External B-phase Pulse inputs to #4-axis
B6	PE4	Enable for External Pulse of #4-axis
A7	CSTA	Simultaneous Start
B7	CSTP	Simultaneous Stop
A8	+5V	+5V
B8	+5V	+5V
A9	+5V	+5V
B9	GND	GND
A10	GND	GND
B10	GND	GND

6-5. Type of Connector

- Connector type which this board uses

No.	Manufacturer	Model	Description
CN1	3M	7650-5002SC	MIL-standard, 50-pin box pin header
CN2	3M	7650-5002SC	MIL-standard, 50-pin box pin header
CN3	JAE	IL-2P-S3FP2	IL series connector
CN4	JAE	PS-20PLB-D4T1-FL1	Dual line, 2.54mm pitch connector

We will not provide the mating connectors for the board. The above information is provided so that the user can choose the correct mates for the board's connectors.

7. Address

7-1. Base Address

The Initial setting is "0x0a00".

ON : "0"

OFF : "1"

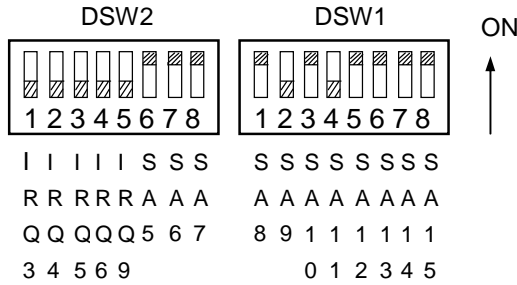

7-2. Address Map

- Axis Map

SA4	SA3	Range of Address (Hex.)	Description
0	0	00 to 07	For Axis #1
0	1	08 to 0F	For Axis #2
1	0	10 to 17	For Axis #3
1	1	18 to 1F	For Axis #4

- Map of Internal Axis

Write Cycle

SA2	SA1	Mnemonic	Description
0	0	COMW	Write the command to a designated axis
0	1	OPTW	Changing the general-purpose output status
1	0	BUFW0	Writing to the I/O buffer (bits 15 to 0)
1	1	BUFW1	Writing to the I/O buffer (bits 31 to 16)

Read Cycle

SA2	SA1	Mnemonic	Description
0	0	MSTSW	Write the command to a designated axis
0	1	SSTSW	Changing the general-purpose output status
1	0	BUFW0	Writing to the I/O buffer (bits 15 to 0)
1	1	BUFW1	Writing to the I/O buffer (bits 31 to 16)

8. Interrupt Request

- IRQ is not set during initial setting.
- Set by switch ON.
- When it needs IRQ to PC/104 bus, please set any switch of IRQ3, 4, 5, 6 or 9.

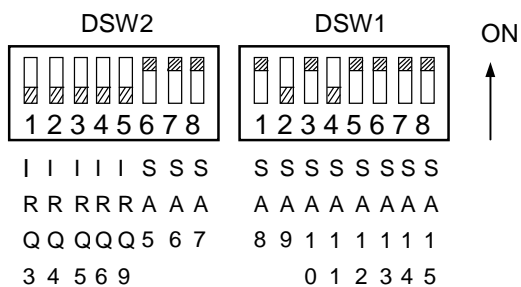

9. Bus Timing

9-1. Read Cycle

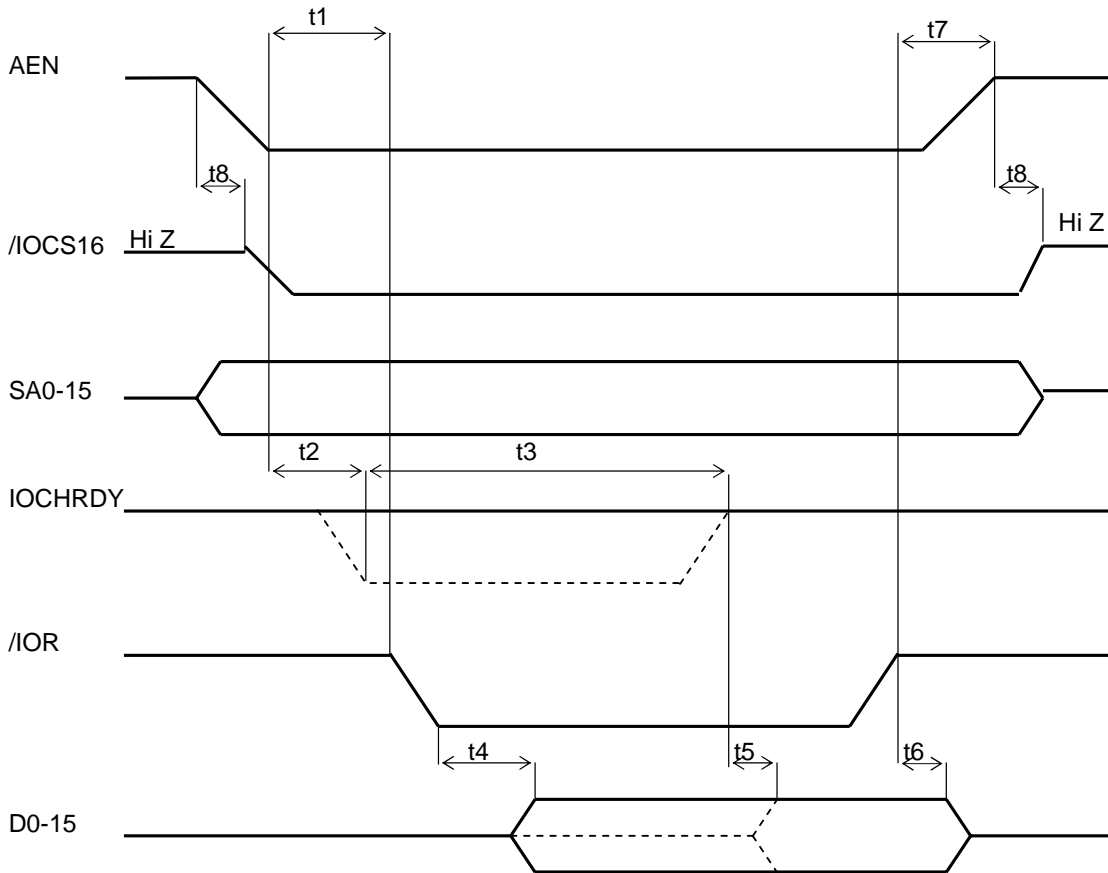

Symbol	Item	Min.	Max.	unit
t1	Address setup time	29		nsec
t2	IOCHRDY delay time		87	nsec
t3	CPU wait request time		239	nsec
t4	Data output delay time		50	nsec
t5	Data output delay time		33	nsec
t6	Data float delay time		34	nsec
t7	Address hold time	5		nsec
t8	/IOCS16 delay time		42	nsec

9-2. Write Cycle

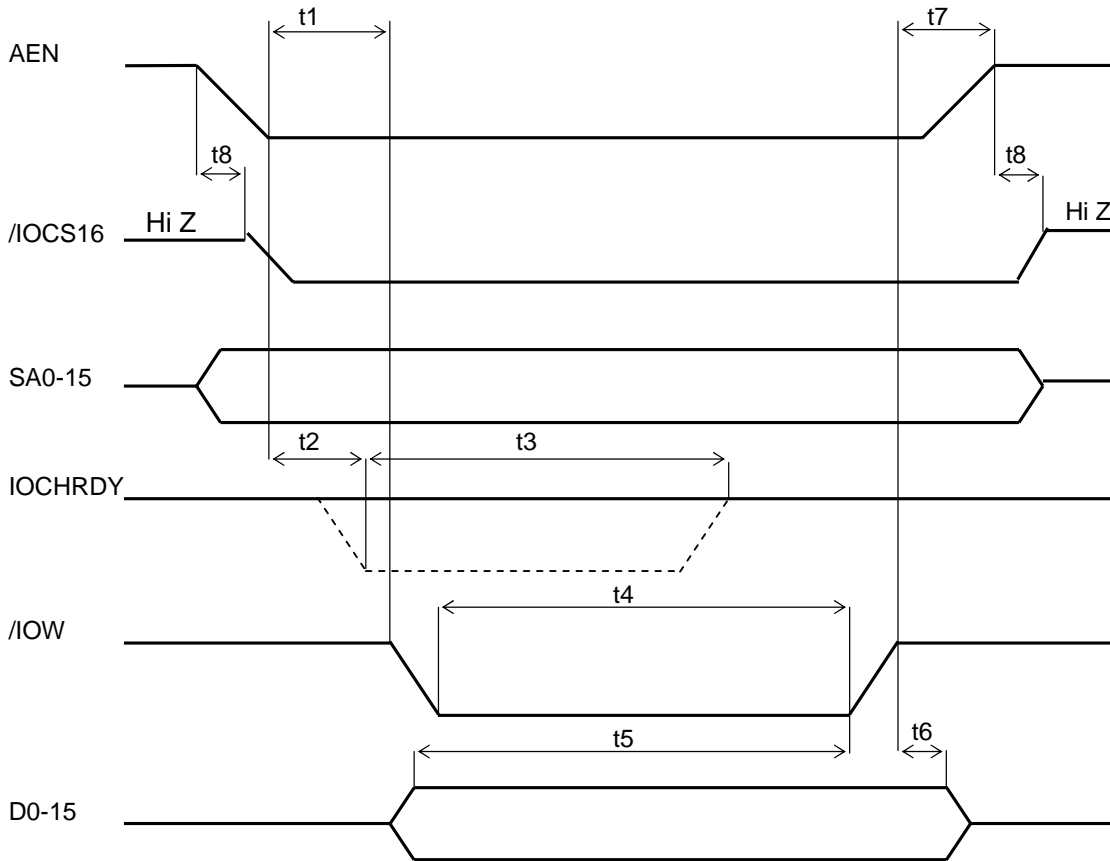

Symbol	Item	Min.	Max.	unit
t1	Address setup time	29		nsec
t2	IOCHRDY delay time		87	nsec
t3	CPU wait request time		239	nsec
t4	/IOW signal width	15		nsec
t5	Data setup time	19		nsec
t6	Data hold time	5		nsec
t7	Address hold time	5		nsec
t8	/IOCS16 delay time		42	nsec

Note: t4 is time when CPU wait demand is output, after IOCHRDY is set to H until /IOW is set to H.

10. Dimension

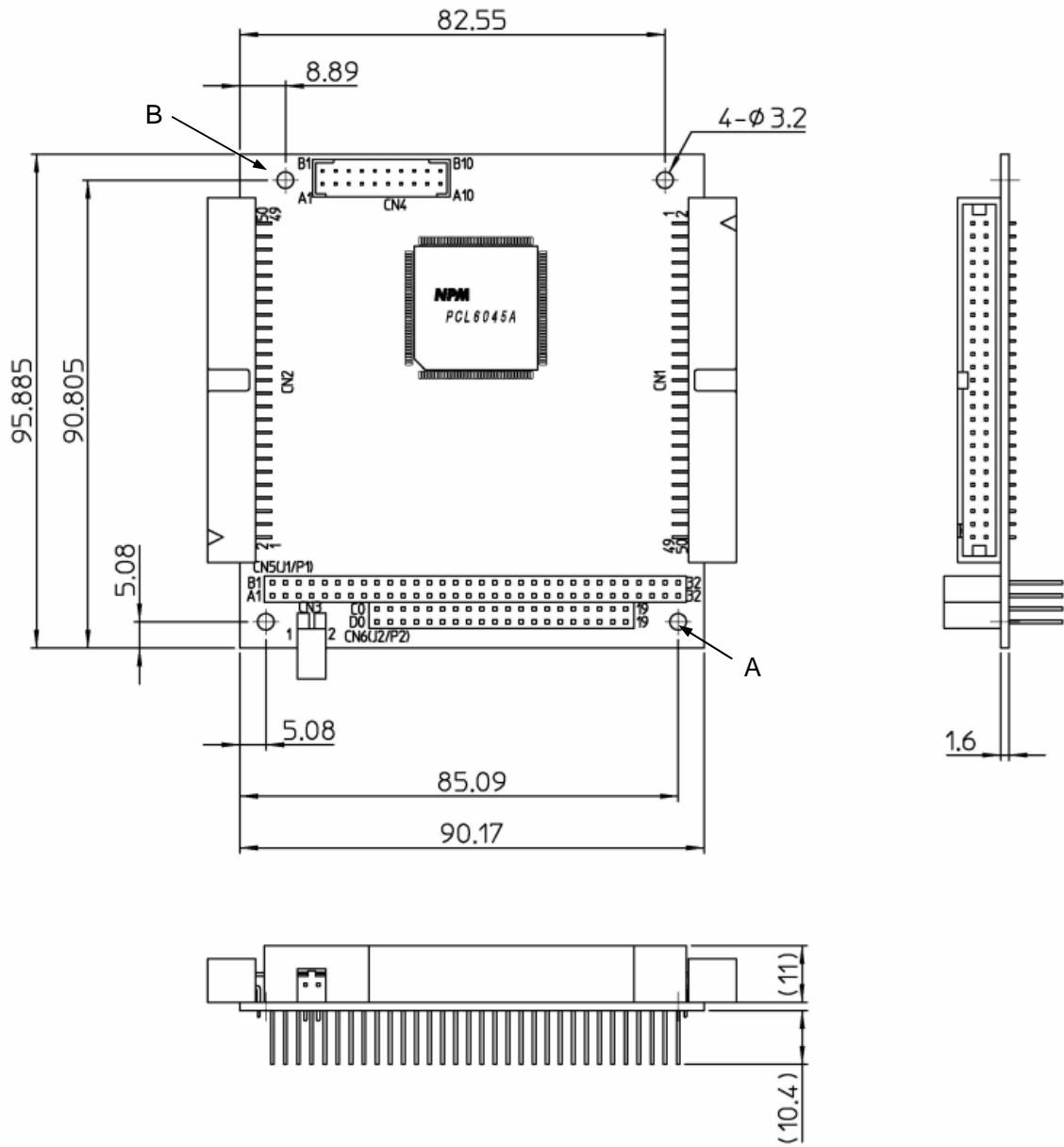

Units are in mm

Note: Please perform the following in order to prevent malfunction by noise :

- Please use the shielded cable for CN 1 and 2
- FG of CN 1 and 2 is connected to the through hole of A and B (respectively)
Please connect the frame of the control system to it with a stacking spacer.

11. Connection Example

11-1. Command pulse Output: (PULS*P, PULS*N, DIR*P, DIR*N)

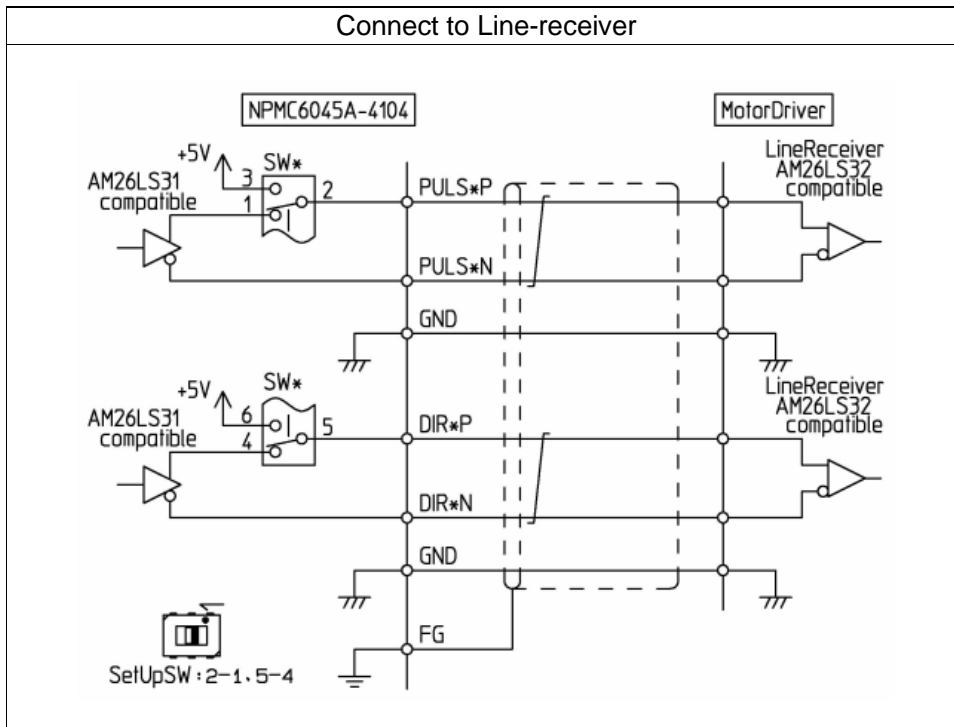
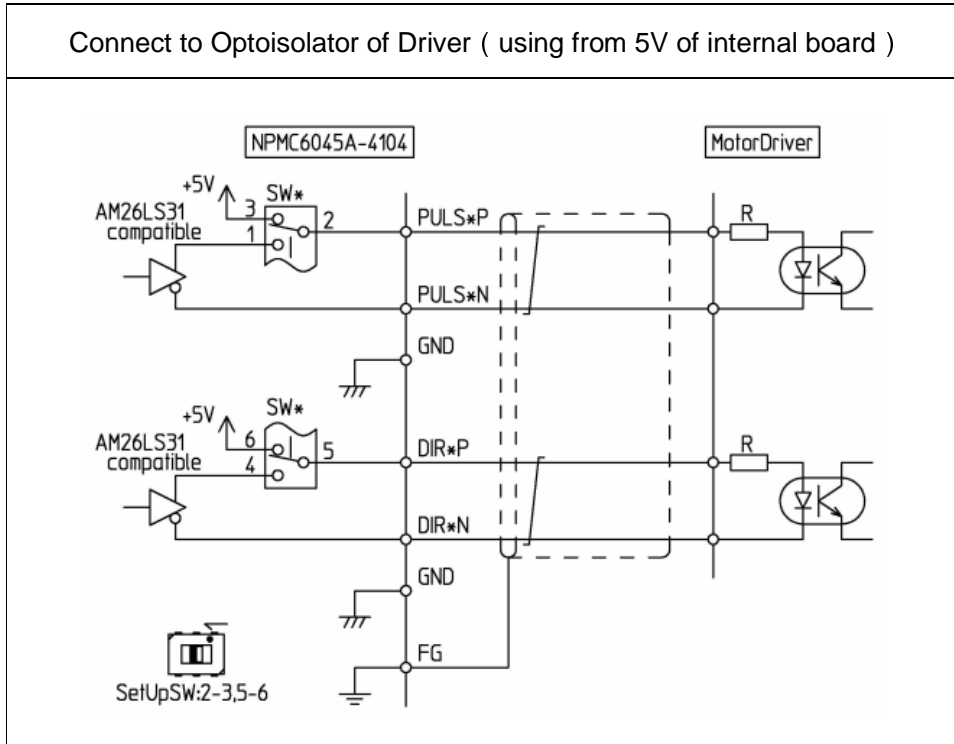

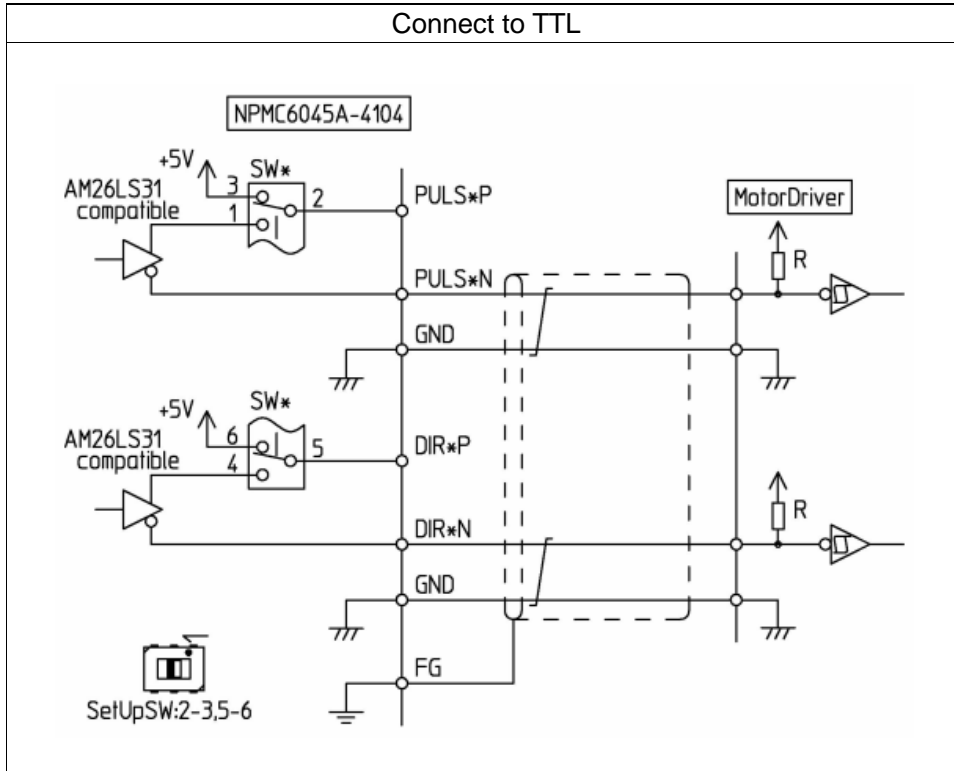
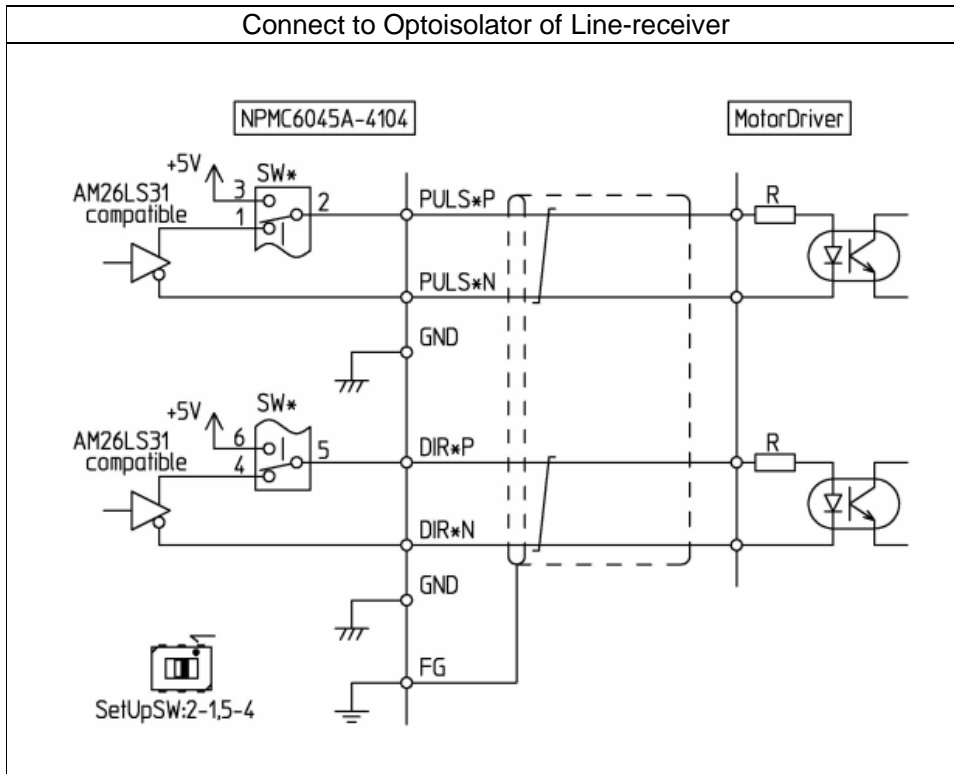

**11-2. Encoder input:
(EA*, EB*, EZ*)**

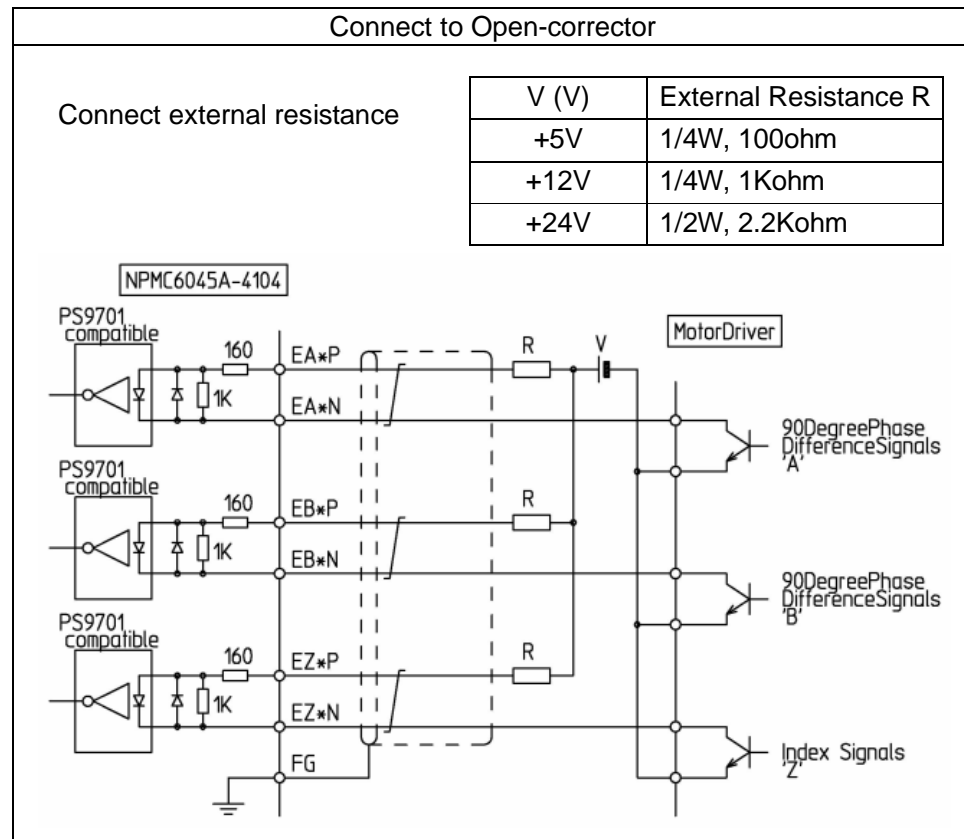
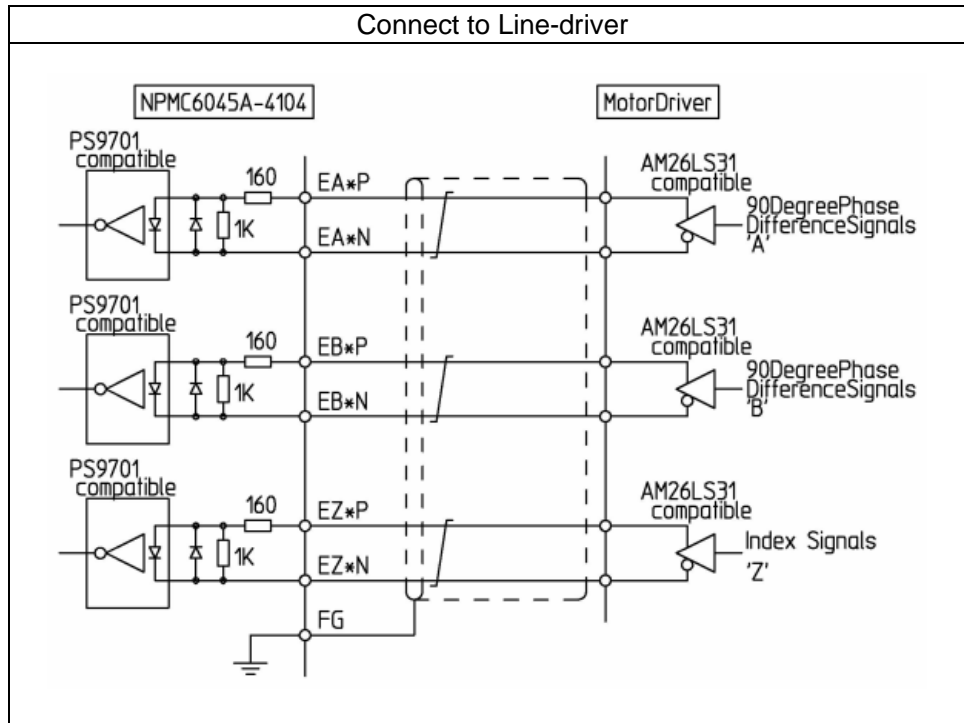

**11-3. Multipurpose or Digital Servo Input:
(MPIN*1, ALM*, INP*)**

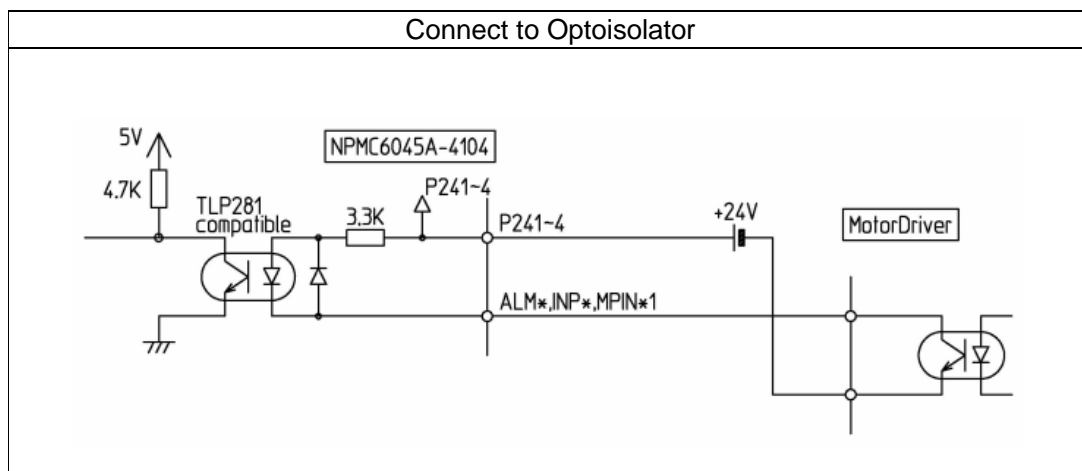

**11-4. Multipurpose or Digital Servo Output:
(MPOUT*1, MPOUT*2, ERC*)**

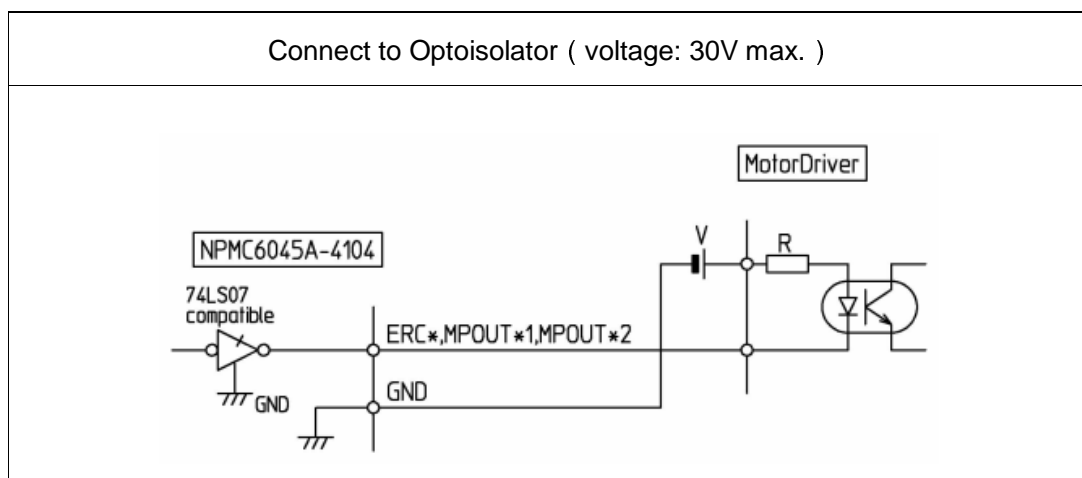

**11-5. Emergency Stop Input:
(EMG)**

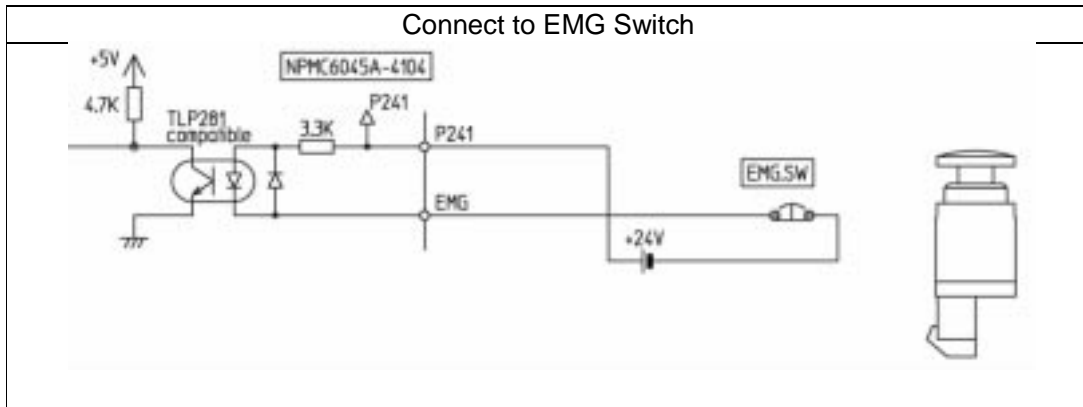

**11-6. Mechanical Sensor Input:
(PEL*, MEL*, SD*/PCS*, ORG*)**

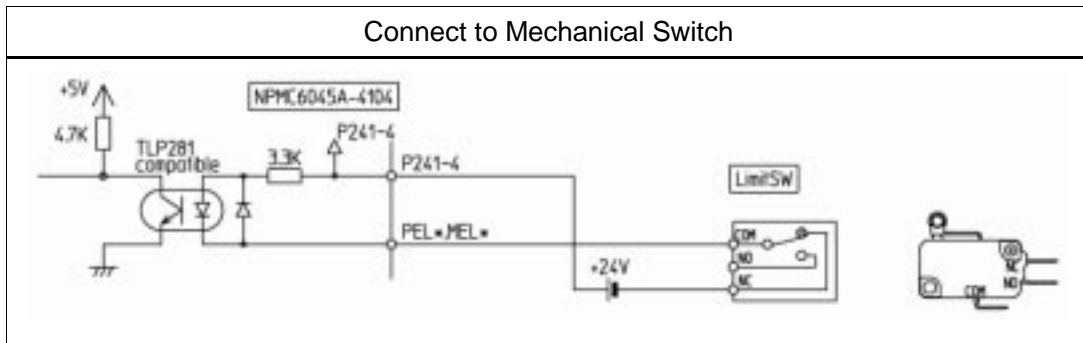
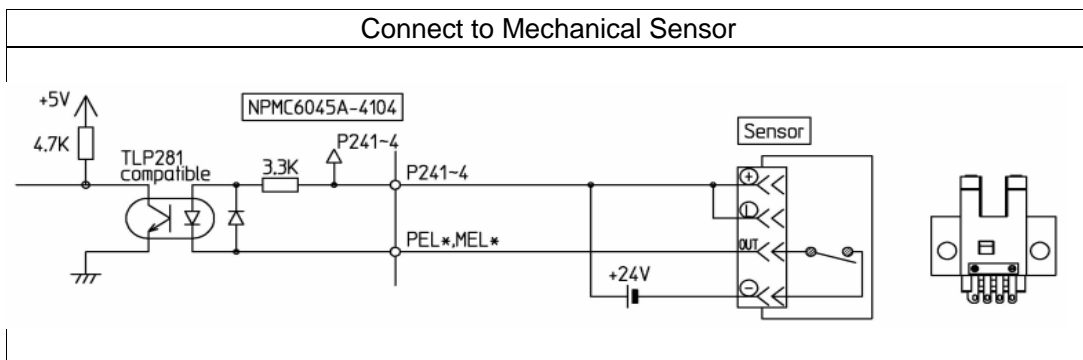

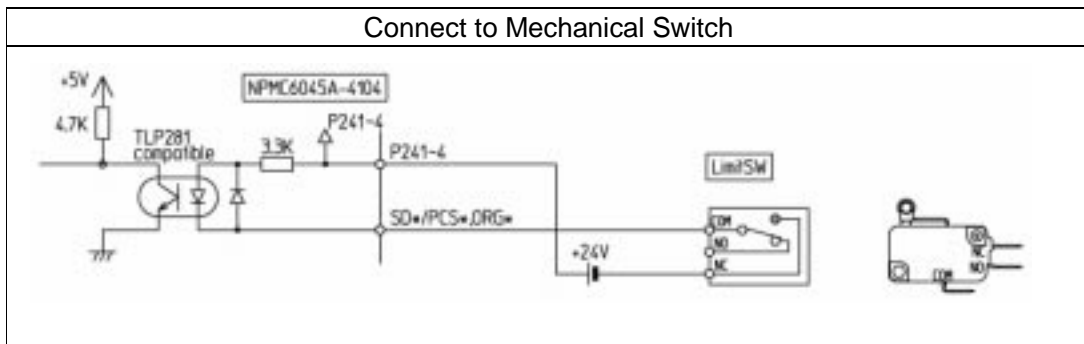
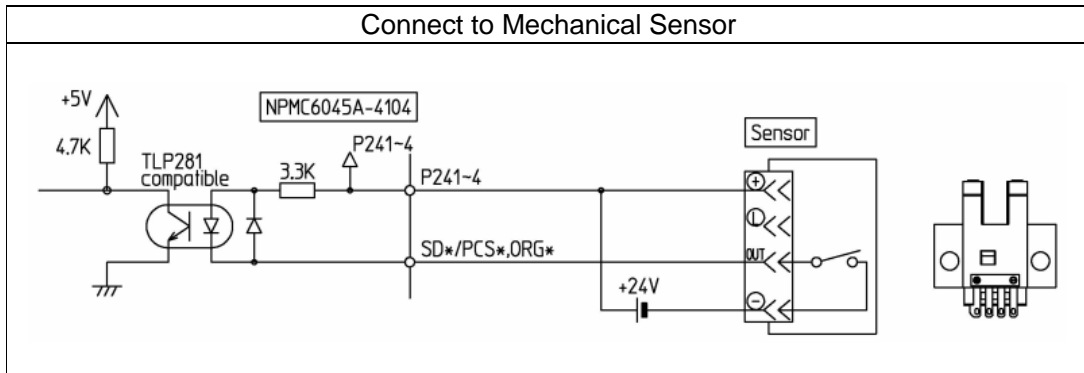

**11-7. Simultaneous Start and Stop In/Output:
(CSTA, CSTOP)**

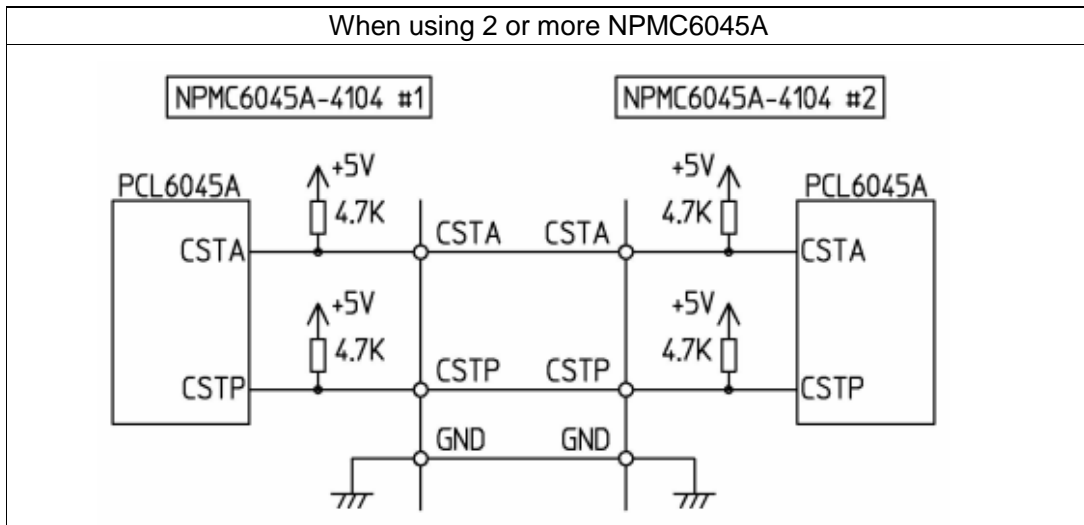

**11-8. Manual Pulsar or Enable/Disable input:
(PA*, PB*, PE*)**

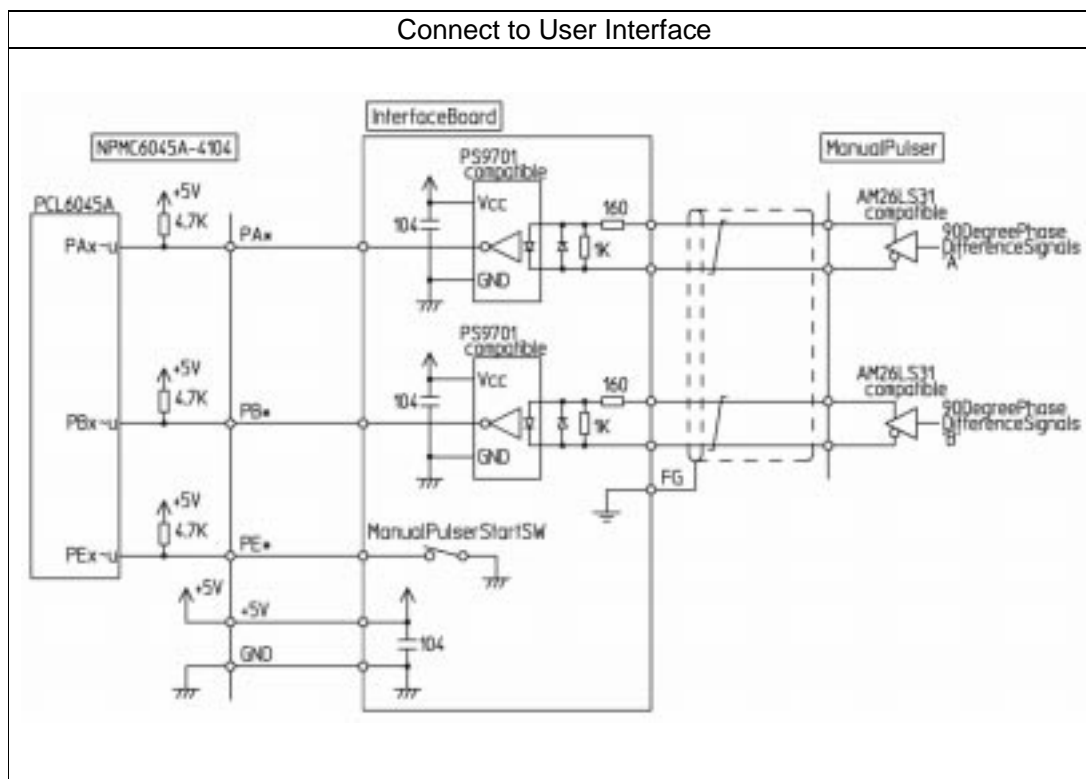

Reference Circuits

12. Position of Switch

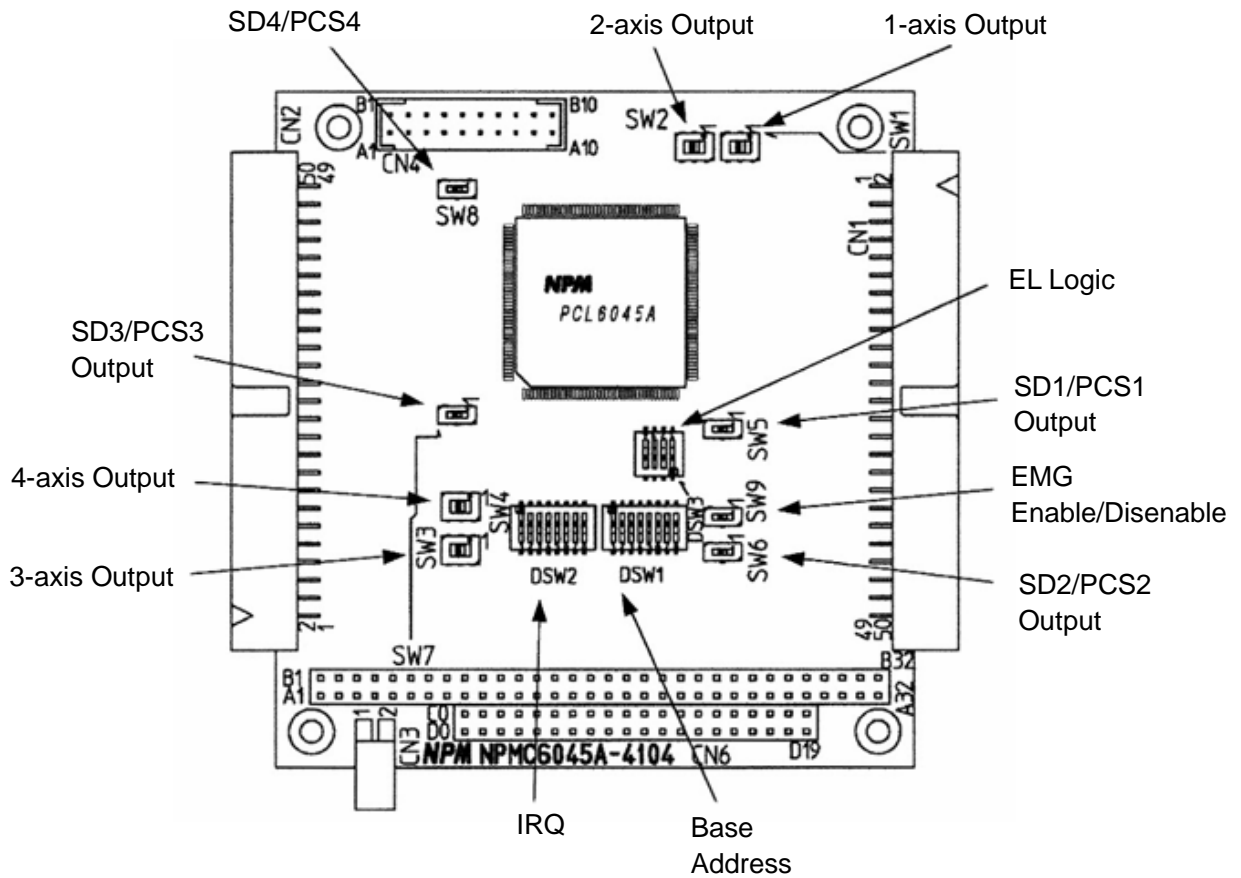

13. Accessories

- Stacking spacer 4 pieces
- Nut 4 pieces

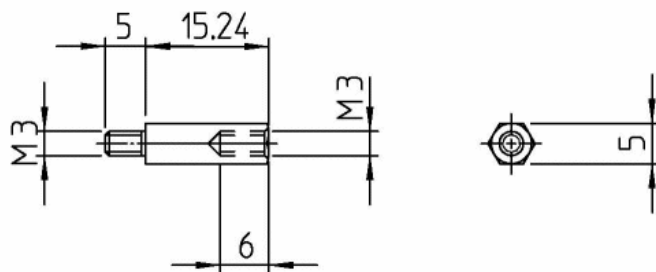

Units are in mm